

FULL THROTTLE

SUSPENSION



2013 CATALOG

LEVELING KITS

LEVELING KITS
4WD
CHEVY / GMC / DODGE
FORD / TOYOTA

PART #	YEAR	TITLE	LIFT SIZE	2WD / 4WD
CHEVY / GMC LEVELING KITS				
38316	2011-2013	SILVERADO / SIERRA 2500HD / 3500HD	2.5" FRONT	2WD / 4WD
38305	2000-2010	SILVERADO / SIERRA 1500 / 2500HD / 3500HD	2.5" FRONT	2WD / 4WD
38305	2000-2010	SILVERADO / SIERRA 3500HD DUALY	2.5" FRONT	2WD / 4WD
38305	2000-2010	SUBURBAN / AVALANCHE / YUKON XL 2500	2.5" FRONT	2WD / 4WD
38119	2007-2013	SILVERADO / SIERRA 1500 W/ STEEL SPACER	2.25" FRONT	2WD / 4WD
38119	2007-2013	TAHOE / SUBURBAN / AVALANCHE / YUKON XL 1500 W/ STEEL SPACER	2.25" FRONT	2WD / 4WD
38110	2007-2013	SILVERADO / SIERRA 1500 W/ ALUMINUM SPACER	2.25" FRONT	2WD / 4WD
38110	2007-2013	TAHOE / SUBURBAN / AVALANCHE / YUKON XL 1500 W/ ALUMINUM SPACER	2.25" FRONT	2WD / 4WD
38120	2007-2013	TAHOE / SUBURBAN / AVALANCHE / YUKON XL 1500	2.25 F / 1.5 R	2WD / 4WD
38302	1999-2006	SILVERADO / SIERRA 1500 CLASSIC	2.5" FRONT	4WD
38302	2000-2006	ESCALADE / DENALI	2.5" FRONT	2WD / 4WD
38302	2000-2006	TAHOE / SUBURBAN / AVALANCHE / YUKON / YUKON XL	2.5" FRONT	2WD / 4WD
38211	2000-2006	ESCALADE / DENALI	2.5 F / 1.5 R	2WD / 4WD
38211	2000-2006	TAHOE / SUBURBAN / AVALANCHE / YUKON / YUKON XL	2.5 F / 1.5 R	2WD / 4WD
486500	2011-2013	UREA TANK SKID PLATE (DIESEL EXHAUST FLUID TANK)	ALL	2WD / 4WD

PART #	YEAR	TITLE	LIFT SIZE	2WD / 4WD
DODGE RAM LEVELING KITS				
38504	1994-2012	RAM 1500 / 2500 / 3500	1.0" FRONT	4WD
38505	1994-2012	RAM 1500 / 2500 / 3500	2.0" FRONT	4WD
38506	1994-2012	RAM 1500 / 2500 / 3500	3.0" FRONT	4WD
38507	2003-2012	RAM 1500 / 2500 / 3500 W/ STEERING AND TRACK BAR DROP	3.0" FRONT	4WD
38511	2002-2005	RAM 1500	2.5" FRONT	4WD
38510	2006-2008	RAM 1500	2.5" FRONT	4WD
38508	2009-2013	RAM 1500	3.0" FRONT	4WD

PART #	YEAR	TITLE	LIFT SIZE	2WD / 4WD
FORD LEVELING KITS				
38602	2009-2013	FORD F150	3.0" FRONT	2WD / 4WD
38602	2004-2008	FORD F150	3.0" FRONT	2WD / 4WD
38604	2009-2013	FORD F150	2.5" FRONT	2WD / 4WD
38604	2004-2008	FORD F150	2.5" FRONT	2WD / 4WD
38606	2004-2013	FORD F150	2.0" FRONT	2WD / 4WD
38608	2010-2013	F150 RAPTOR	2.0" FRONT	4WD
38612	1997-2003	F150 / HERITAGE EXPEDITION 5 LUG	2.5" FRONT	4WD
38612	1997-2003	F250 LIGHT DUTY 7 LUG	2.5" FRONT	4WD
38614	2005-2013	F250 / F350 / SUPER DUTY	1.0" FRONT	4WD
38616	2005-2013	F250 / F350 / SUPER DUTY	2.0" FRONT	4WD
38617	2005-2013	F250 / F350 / SUPER DUTY	2.5" FRONT	4WD
38618	2005-2013	F250 / F350 / SUPER DUTY	3.0" FRONT	4WD

PART #	YEAR	TITLE	LIFT SIZE	2WD / 4WD
TOYOTA LEVELING KITS				
38408	2005-2013	TACOMA	3.0" FRONT	2WD / 4WD
38409	2005-2013	TACOMA	2.25" FRONT	2WD / 4WD
38406	2003-2009	FJ CRUISER / 4 RUNNER	3.0" FRONT	2WD / 4WD
38400	2007-2013	TUNDRA	2.4" FRONT	2WD / 4WD
38401	2007-2013	TUNDRA	3.0" FRONT	2WD / 4WD
38402	2007-2013	TUNDRA TRD	3.0" FRONT	2WD / 4WD



4" 2011-2013 CHEVY / GMC HD LEVELING KIT

- Complete bolt on design that allows for easy installation
- Replacement upper control arms with serviceable ball joint
- No cutting or modification of of factory bump stops
- Designed to work with factory Stabilitrack
- Utilizes factory shocks and springs for factory ride quality
- 1/4" Steel skid plate to protect front differential (on 4x4 and all AWD models)
- 4WD Kit includes differential drops
- Durable black semi gloss powder coat finish.



Max Recommended Tire Size 33"
Max Recommended Wheel Width 9"

- Basic 2WD Kit Includes**
- 4" Front Box Kit
- .75" Rear Block Kit
- Basic 4WD Kit Includes**
- 4" Front Box Kit
- .75" Rear Block Kit
- Shocks Sold Separately
- Please see options

2WD SILVERADO HD / SIERRA HD
F4.0" / R.75" Part # 38138



4WD SILVERADO HD / SIERRA HD
F4.0" / R.75" Part # 38136



PART #	YEAR	TITLE	FOOTNOTES	LIFT SIZE	2WD / 4WD
4" 2011-2013 CHEVY / GMC SILVERADO / SIERRA 2500HD / 3500HD					
38136	2011-2013	SILVERADO / SIERRA 2500HD / 3500HD F 4.0" / R.75"	19, 52	4"	4WD
38138	2011-2013	SILVERADO / SIERRA 2500HD / 3500HD F 4.0" / R.75"	19, 52	4"	2WD
SINGLE FRONT SHOCK STOCK LOCATION					
C2065-625RUU	2011-2013	FTS 2.0 REMOTE RESERVOIR 6.5" TRAVEL CHROME FINISH (STOCK FRONT LOCATION)	29, 30	4"	2WD / 4WD
B2065-625RUU	2011-2013	FTS 2.0 REMOTE RESERVOIR 6.5" TRAVEL BLACK FINISH (STOCK FRONT LOCATION)	29, 31	4"	2WD / 4WD
SINGLE REAR SHOCK STOCK LOCATION					
C2010-625R	2011-2013	FTS 2.0 REMOTE RESERVOIR 10" TRAVEL CHROME FINISH (STOCK REAR LOCATION)	14, 29, 30	4"	2WD / 4WD
B2010-625R	2011-2013	FTS 2.0 REMOTE RESERVOIR 10" TRAVEL BLACK FINISH (STOCK REAR LOCATION)	14, 29, 31	4"	2WD / 4WD
ACCESSORIES					
486500	2011-2013	DEF (DIESEL EXHAUST FLUID) TANK	56	ALL	2WD / 4WD
38316	2011-2013	2.5" TORSION KEYS W/ SHOCK SPACERS	52	4"	2WD / 4WD
C2020	2007-2013	FTS 2.0 TO 2.0 BILLET SHOCK CLAMPS CHROME FINISH	38	4"	2WD / 4WD
B2020	2007-2013	FTS 2.0 TO 2.0 BILLET SHOCK CLAMPS BLACK FINISH	38	4"	2WD / 4WD

4" 2007 - 2013 CHEVY / GMC 1500 LEVELING KIT

4" CHEVY / GMC 1500 2007-2013

Complete bolt on design that allows for easy installation
 Replacement upper control arms with serviceable ball joint
 No cutting or modification of factory bump stops
 Designed to work with factory Stabilitrack
 Utilizes factory shocks and springs for factory ride quality
 Steel skid plate to protect front differential
 (on 4x4 and all AWD models)
 Durable black semi gloss powder coat finish.

Max Recommended Tire Size 33"
 Max Recommended Wheel Width 9"



4WD SILVERADO / SIERRA 1500
 F4.0" / R1.75" Part # 38114

AWD DENALI TRUCK 1500
 F4.0" / R1.75" Part # 38115

4WD SILVERADO / SIERRA 1500
 W/ COILOVERS F4.0" / R1.75" Part # 38113



4" 2007-2013 CHEVY / GMC SILVERADO / SIERRA 1500						
38102	2007-2013	SILVERADO / SIERRA 1500	F 4.0" / R 1.75"	19, 37	4"	2WD
38114	2007-2013	SILVERADO / SIERRA 1500	F 4.0" / R 1.75"	19, 37	4"	4WD
38103	2007-2013	SILVERADO / SIERRA 1500	F 4.0" / R 1.75" W/ COILOVERS AND 2.0 FTS R/R REAR SHOCKS	19, 33, 37	4"	2WD
38113	2007-2013	SILVERADO / SIERRA 1500	F 4.0" / R 1.75" W/ COILOVERS AND 2.0 FTS R/R REAR SHOCKS	19, 33, 37	4"	4WD
FRONT COIL OVER SHOCKS COMPLETE						
C8600-7E	2007-2013	FTS 2.5 EMULSION COILOVER SHOCK COMPLETE W/ COILS, MOUNTING BRACKETS		10, 33	4"	2WD / 4WD
C8600-7R	2007-2013	FTS 2.5 REMOTE RESERVOIR COILOVER SHOCK COMPLETE W/ COILS, MOUNTING BRACKETS		10, 33, 57	4"	2WD / 4WD
DOUBLE FRONT SHOCK UPGRADE						
B4945	2007-2013	DOUBLE FRONT HOOPS W/ BALL JOINT UPPER A ARMS		27, 41	4"	2WD / 4WD
C2065-625R	2007-2013	FTS 2.0 REMOTE RESERVOIR 6.5" TRAVEL CHROME FINISH (DOUBLE FRONT SHOCK)		29, 30	4"	2WD / 4WD
B2065-625R	2007-2013	FTS 2.0 REMOTE RESERVOIR 6.5" TRAVEL BLACK FINISH (DOUBLE FRONT SHOCK)		29, 31	4"	2WD / 4WD
SINGLE REAR SHOCK STOCK LOCATION						
C2011-625R	2007-2013	FTS 2.0 REMOTE RESERVOIR 11" TRAVEL CHROME FINISH (STOCK REAR LOCATION)		14, 29, 30	4"	2WD / 4WD
B2011-625R	2007-2013	FTS 2.0 REMOTE RESERVOIR 11" TRAVEL BLACK FINISH (STOCK REAR LOCATION)		14, 29, 31	4"	2WD / 4WD
DOUBLE REAR SHOCK HOOPS						
B5055	2007-2013	DOUBLE REAR SHOCK HOOPS (REQUIRES 8.5" TRAVEL SHOCKS)		27, 41	4"	2WD / 4WD
C2085-625R	2007-2013	FTS 2.0 REMOTE RESERVOIR 8.5" TRAVEL CHROME FINISH		26, 29, 30	4"	2WD / 4WD
B2085-625R	2007-2013	FTS 2.0 REMOTE RESERVOIR 8.5" TRAVEL BLACK FINISH		26, 29, 31	4"	2WD / 4WD
4" 2007-2013 CHEVY / GMC TAHOE, SUBURBAN, AVALANCHE, YUKON						
38124	2007-2013	TAHOE, SUBURBAN, AVALANCHE, YUKON	F 4.0" / R 1.75"	43	4"	4WD
38122	2007-2013	TAHOE, SUBURBAN, AVALANCHE, YUKON	F 4.0" / R 1.75"	43	4"	2WD
SINGLE REAR SHOCK STOCK LOCATION						
C2011-625R	2007-2013	FTS 2.0 REMOTE RESERVOIR 11" TRAVEL CHROME FINISH (STOCK REAR LOCATION)		14, 29, 30	4"	2WD / 4WD
B2011-625R	2007-2013	FTS 2.0 REMOTE RESERVOIR 11" TRAVEL BLACK FINISH (STOCK REAR LOCATION)		14, 29, 31	4"	2WD / 4WD
4" 2007-2013 CHEVY / GMC DENALI 1500 (TRUCK)						
38115	2007-2013	AWD GMC DENALI (TRUCK) F4.0" / R 1.75" *INCLUDES CV FRONT DRIVE SHAFT		37, 35	4"	AWD
SINGLE REAR SHOCK STOCK LOCATION						
B2011-625R	2007-2013	FTS 2.0 REMOTE RESERVOIR 11" TRAVEL BLACK FINISH (STOCK REAR LOCATION)		14, 29, 31	4"	2WD / 4WD
C2011-625R	2007-2013	FTS 2.0 REMOTE RESERVOIR 11" TRAVEL CHROME FINISH (STOCK REAR LOCATION)		14, 29, 31	4"	2WD / 4WD
4" 2007-2013 CHEVY / GMC DENALI 1500 (SUV)						
38125	2007-2013	AWD GMC ESCALADE, DENALI (SUV) F4.0" / R 1.75" *INCLUDES CV FRONT DRIVE SHAFT		37, 35, 43	4"	2WD / 4WD
SINGLE REAR SHOCK STOCK LOCATION						
C2011-625R	2007-2013	FTS 2.0 REMOTE RESERVOIR 11" TRAVEL CHROME FINISH (STOCK REAR LOCATION)		14, 29, 30	4"	2WD / 4WD
B2011-625R	2007-2013	FTS 2.0 REMOTE RESERVOIR 11" TRAVEL BLACK FINISH (STOCK REAR LOCATION)		14, 29, 31	4"	2WD / 4WD
BILLET SHOCK CLAMPS						
C2020	2007-2013	FTS 2.0 TO 2.0 BILLET SHOCK CLAMPS CHROME FINISH		38	4"	2WD / 4WD
B2020	2007-2013	FTS 2.0 TO 2.0 BILLET SHOCK CLAMPS BLACK FINISH		38	4"	2WD / 4WD
ACCESSORIES						
CVDL35	2007-2013	CV FRONT DRIVE SHAFT 35"		35	4"	AWD
CBK25-275T	2007-2013	2.75" TAPERED REAR BLOCK KIT W/ 9/16" X 2.5" X 12" SQUARE U BOLTS		57	4"	2WD / 4WD
B426	2007-2013	REPLACEMENT UPPER BALL JOINT (PRESSED IN)			4"	2WD / 4WD

TRUCK
SUV

Basic 2WD/4WD Truck kit includes:

- 4" Front Box Kit
- 2.75" Rear Block Kit

Basic AWD Truck kit includes:

- 4" Front Box Kit
- 2.75" Rear Block Kit
- CV Front Drive Shaft

Basic 2WD/4WD SUV kit includes:

- 4" Front Box Kit
- 1.75" Rear Box Kit

Basic AWD SUV kit includes:

- 4" Front Box Kit
- 1.75" Rear Box Kit
- CV Front Drive Shaft

Shocks Sold Separately
 Please see options

4WD TAHOE / SUBURBAN
 AVALANCHE / YUKON
 F4.0" / R1.75" Part # 38124

2WD SILVERADO / SIERRA 1500
 F4.0" / R1.75" Part # 38102

7" 2007 - 2013 CHEVY / GMC 1500

100% Bolt on 7" Spindle Kit
 Front differential is dropped a full 7" to maintain proper CV axle angles
 Impact struts to distribute front suspension impact loads through frame
 Utilizes the factory front bump stops for superior ride quality
 Designed to work with factory stabilizer and AWD models
 Semi Gloss black powder-coat for a long lasting great look
 Fabricated Steel Blocks (Non Casted) w/ Grade 8 U Bolts
 One piece strut extension no need to remove factory strut
 No cutting on front differential or factory bump stops
 Cross-member are constructed of 1/4" thick steel
 Lifetime Warranty against manufacturers defects
 No exhaust modification required

Max Recommended Tire Size 35"
 Max Recommended Wheel Width 12"
 Required 17" or larger Wheel with no more than 5" Backspace



Basic 2WD kit includes:
 7" Front Box Kit
 6.25" Rear Block Kit
 LH / RH Steering Knuckles
Basic 4WD kit includes:
 7" Front Box Kit
 6.25" Rear Block Kit
 LH / RH Steering Knuckles
Basic AWD kit includes:
 7" Front Box Kit
 6.25" Rear Block Kit
 LH / RH Steering Knuckles
 CV Front Drive Shaft
Shocks Sold Separately.
 Please see options below

4WD SILVERADO / SIERRA 1500 W/ COILOVERS Part # 84912

AWD DENALI 1500 BASIC KIT Part # 84916

4WD SILVERADO / SIERRA 1500 BASIC KIT Part # 84902



PART #	YEAR	TITLE	FOOTNOTES	LIFT SIZE	2WD / 4WD
7" 2007-2013 CHEVY / GMC SILVERADO / SIERRA 1500					
84901	2007-2013	SILVERADO / SIERRA 1500 BASIC KIT	2, 19	7"	2WD
84911	2007-2013	SILVERADO / SIERRA 1500 W/ COILOVERS	2, 19	7"	2WD
84902	2007-2013	SILVERADO / SIERRA 1500 BASIC KIT	2, 19	7"	4WD
84912	2007-2013	SILVERADO / SIERRA 1500 W/ COILOVERS	2, 19	7"	4WD
84916	2007-2013	GMC DENALI 1500 BASIC KIT *INCLUDES CV FRONT DRIVE SHAFT	2, 19, 37, 35	7"	AWD
84918	2007-2013	GMC DENALI 1500 W/ COILOVERS *INCLUDES CV FRONT DRIVE SHAFT	2, 19, 37, 35	7"	AWD
DOUBLE FRONT SHOCK UPGRADE					
84941	2007-2013	DOUBLE FRONT HOOPS W/ UNI BALL UPPER A ARMS	27, 40, 41	7"	2WD / 4WD
84945	2007-2013	DOUBLE FRONT HOOPS W/ BALL JOINT UPPER A ARMS	27, 41	7"	2WD / 4WD
84940	2007-2013	DOUBLE FRONT HOOPS W/ UPPER A ARMS BRACKETS	27	7"	2WD / 4WD
84944	2007-2013	UNI BALL UPPER A ARMS	40, 41	7"	2WD / 4WD
84947	2007-2013	BALL JOINT UPPER A ARMS	41	7"	2WD / 4WD
C2065-625R	2007-2013	FTS 2.0 REMOTE RESERVOIR 6.5" TRAVEL CHROME FINISH (DOUBLE FRONT SHOCK)	29, 30	7"	2WD / 4WD
B2065-625R	2007-2013	FTS 2.0 REMOTE RESERVOIR 6.5" TRAVEL BLACK FINISH (DOUBLE FRONT SHOCK)	29, 31	7"	2WD / 4WD
FRONT ADJUSTABLE STRUT / COILOVER SHOCKS COMPLETE					
C8500-20	2007-2013	FTS REPLACEMENT STRUT ADJUSTABLE 7" - 9"	62	7"	2WD / 4WD
C8500-7E	2007-2013	FTS 2.5 EMULSION COILOVER SHOCK COMPLETE W/ COILS, MOUNTING BRACKETS	10, 33	7"	2WD / 4WD
C8500-7R	2007-2013	FTS 2.5 REMOTE RESERVOIR COILOVER SHOCK COMPLETE W/ COILS, MOUNTING BRACKETS	10, 33, 57	7"	2WD / 4WD
SINGLE REAR SHOCK STOCK LOCATION					
C2012-625R	2007-2013	FTS 2.0 REMOTE RESERVOIR 12" TRAVEL CHROME FINISH (STOCK REAR LOCATION)	29, 30	7"	2WD / 4WD
B2012-625R	2007-2013	FTS 2.0 REMOTE RESERVOIR 12" TRAVEL BLACK FINISH (STOCK REAR LOCATION)	29, 31	7"	2WD / 4WD
REAR SHOCK BRACKET / DOUBLE REAR SHOCK HOOP					
85049	2007-2013	DOUBLE REAR SHOCK BRACKET KIT (REQUIRES 8.5" TRAVEL SHOCKS)	12, 18, 27	7"	2WD / 4WD
85055	2007-2013	DOUBLE REAR SHOCK HOOPS (REQUIRES 8.5" TRAVEL SHOCKS)	27	7"	2WD / 4WD
C2085-625R	2007-2013	FTS 2.0 REMOTE RESERVOIR 8.5" TRAVEL CHROME FINISH	29, 30	7"	2WD / 4WD
B2085-625R	2007-2013	FTS 2.0 REMOTE RESERVOIR 8.5" TRAVEL BLACK FINISH	29, 31	7"	2WD / 4WD
BILLET SHOCK CLAMPS					
C2020	2007-2013	FTS 2.0 TO 2.0 BILLET SHOCK CLAMPS CHROME FINISH	38	7"	2WD / 4WD
B2020	2007-2013	FTS 2.0 TO 2.0 BILLET SHOCK CLAMPS BLACK FINISH	38	7"	2WD / 4WD
ACCESSORIES					
84926	2007-2013	FRONT / REAR STEEL BRAIDED BRAKE LINE KIT (SINGLE REAR)	79	7"	2WD / 4WD
84927	2007-2013	FRONT / REAR STEEL BRAIDED BRAKE LINE KIT (DUAL REAR)	79	7"	2WD / 4WD
84943	2007-2013	HEAVY DUTY HEIMS JOINT STEERING CONVERSION KIT	19, 22, 23	7"	2WD / 4WD
84946	2007-2013	DOUBLE FRONT STEERING STABILIZER KIT W/ BASIC HYDRAULIC STABILIZERS	56	7"	2WD / 4WD
84948	2007-2013	DOUBLE FRONT STEERING STABILIZER KIT W/ FTS 2.0 CHROME STABILIZERS	30, 56	7"	2WD / 4WD
84949	2007-2013	DOUBLE FRONT STEERING STABILIZER KIT W/ FTS 2.0 BLACK STABILIZERS	31, 56	7"	2WD / 4WD
13963	2007-2013	BOLT ON TRACTION BAR KIT 63" (SHORT BED)	27, 56, 58	7"	2WD / 4WD
13970	2007-2013	BOLT ON TRACTION BAR KIT 70" (LONG BED)	27, 56, 58	7"	2WD / 4WD
84950	2007-2013	REAR AIR BAG KIT (USE W/ STOCK SPRINGS)	27, 56	7"	2WD / 4WD
84951	2007-2013	REAR AIR BAG KIT (USE W/ FTS 7" SPRINGS)	27, 56	7"	2WD / 4WD
CBK25-625T	2007-2013	6.25" TAPERED REAR BLOCK KIT W/ 9/16" X 2.5" X 15.5" SQUARE U BOLTS	57	7"	2WD / 4WD
C7	2007-2013	7" REAR LEAF SPRINGS	55	7"	2WD / 4WD
CVDL36	2007-2013	CV FRONT DRIVE SHAFT 36"	35	7"	AWD



BASIC SHOCKS

Rear Shock Stock Location	132000
Double Front Shock	120500
Double Rear Shock	122500

7" 2007 - 2013 CHEVY / GMC / CADILLAC 1500 SUV

7"
INCH

2007-2013
CHEVY / GMC
1500 SUV

100% Bolt on 7" Spindle Kit
Front differential is dropped a full 7" to maintain proper CV axle angles
Impact struts to distribute front suspension impact loads through frame
Utilizes the factory front bump stops for superior ride quality
Designed to work with factory stabiltrack and AWD models
Semi Gloss black powder-coat for a long lasting great look
No cutting on front differential or factory bump stops
Cross-member are constructed of 1/4" thick steel
Lifetime Warranty against manufactures defects
Rear kit utilizes factory coils for stock ride
AWD kits includes CV front drive shaft
No exhaust modification required
Max Recommended Tire Size 35"
Max Recommended Wheel Width 12"
Required 17" or larger Wheel with no more than 5" Backspace



Basic 2WD kit includes:
7" Front Box Kit
6.25" Rear Box Kit
LH/ RH Steering Knuckles

Basic 4WD kit includes:
7" Front Box Kit
6.25" Rear Box Kit
LH/ RH Steering Knuckles

Basic AWD kit includes:
7" Front Box Kit
6.25" Rear Box Kit
LH/ RH Steering Knuckles
CV Front Drive Shaft

Basic Kit Includes Rear Shock brackets
Upgrade Shocks Sold Separately
Please see options below

4WD TAHOE / SUBURBAN / AVALANCHE / YUKON 1500
W/ COILOVERS **Part # 84906**

AWD DENALI / ESCALADE 1500
BASIC KIT **Part # 84909**

4WD TAHOE / SUBURBAN / AVALANCHE / YUKON 1500
BASIC KIT **Part # 84903**



Part# C8500-7E



Part# C8500-7R



Part# 85060



Part# 85061

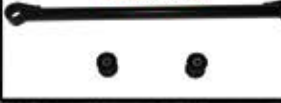

PART #	YEAR	TITLE	FOOTNOTES	LIFT SIZE	2WD / 4WD
7" 2007-2013 CHEVY / GMC TAHOE / SUBURBAN / AVALANCHE / YUKON / DENALI 1500					
84903	2007-2013	TAHOE / SUBURBAN / AVALANCHE / YUKON 1500 BASIC KIT (NON AUTO RIDE)		4, 18, 19, 98	7" 2WD
84905	2007-2013	TAHOE / SUBURBAN / AVALANCHE / YUKON 1500 W/ COILOVERS (NON AUTO RIDE)		4, 18, 19, 98	7" 2WD
84913	2007-2013	TAHOE / SUBURBAN / AVALANCHE / YUKON 1500 BASIC KIT (W/AUTO RIDE)		4, 18, 19, 98	7" 2WD
84904	2007-2013	TAHOE / SUBURBAN / AVALANCHE / YUKON 1500 BASIC KIT (NON AUTO RIDE)		4, 18, 19, 98	7" 4WD
84906	2007-2013	TAHOE / SUBURBAN / AVALANCHE / YUKON 1500 W/ COILOVERS (NON AUTO RIDE)		4, 18, 19, 98	7" 4WD
84914	2007-2013	TAHOE / SUBURBAN / AVALANCHE / YUKON 1500 BASIC KIT (W/ AUTO RIDE)		4, 18, 19, 98	7" 4WD
84908	2007-2013	ESCALADE / DENALI 1500 BASIC KIT (AUTO RIDE)		4, 18, 19, 98	7" 2WD
84909	2007-2013	ESCALADE / DENALI 1500 BASIC KIT (AUTO RIDE) *INCLUDES CV FRONT DRIVE SHAFT		4, 18, 19, 98	7" AWD
DOUBLE FRONT SHOCK UPGRADE					
84941	2007-2013	DOUBLE FRONT HOOPS W/ UNI BALL UPPER A ARMS		27, 40, 41	7" 2WD / 4WD
84945	2007-2013	DOUBLE FRONT HOOPS W/ BALL JOINT UPPER A ARMS		27	7" 2WD / 4WD
84940	2007-2013	DOUBLE FRONT HOOPS W/ UPPER A ARMS BRACKETS		27	7" 2WD / 4WD
84944	2007-2013	UNI BALL UPPER A ARMS		40, 41	7" 2WD / 4WD
84946	2007-2013	BALL JOINT UPPER A ARMS		41	7" 2WD / 4WD
C2065-625R	2007-2013	FTS 2.0 REMOTE RESERVOIR 6.5" TRAVEL CHROME FINISH (DOUBLE FRONT SHOCK)		29, 30	7" 2WD / 4WD
B2065-625R	2007-2013	FTS 2.0 REMOTE RESERVOIR 6.5" TRAVEL BLACK FINISH (DOUBLE FRONT SHOCK)		29, 31	7" 2WD / 4WD
FRONT ADJUSTABLE STRUT / COILOVER SHOCKS COMPLETE					
C8500-20	2007-2013	FTS REPLACEMENT STRUT ADJUSTABLE 7" - 9"		62	7" 2WD / 4WD
C8500-7E	2007-2013	FTS 2.5 EMULSION COILOVER SHOCK COMPLETE W/ COILS, MOUNTING BRACKETS		10, 33	7" 2WD / 4WD
C8500-7R	2007-2013	FTS 2.5 REMOTE RESERVOIR COILOVER SHOCK COMPLETE W/ COILS, MOUNTING BRACKETS		10, 33, 57	7" 2WD / 4WD
SINGLE REAR SHOCK STOCK LOCATION					
C2012-625R	2007-2013	FTS 2.0 REMOTE RESERVOIR 12" TRAVEL CHROME FINISH (STOCK REAR LOCATION)		29, 30	7" 2WD / 4WD
B2012-625R	2007-2013	FTS 2.0 REMOTE RESERVOIR 12" TRAVEL BLACK FINISH (STOCK REAR LOCATION)		29, 31	7" 2WD / 4WD
BILLET SHOCK CLAMPS					
C2020	2007-2013	FTS 2.0 TO 2.0 BILLET SHOCK CLAMPS CHROME FINISH		38	7" 2WD / 4WD
B2020	2007-2013	FTS 2.0 TO 2.0 BILLET SHOCK CLAMPS BLACK FINISH		38	7" 2WD / 4WD
ACCESSORIES					
84926	2007-2008	FRONT / REAR STEEL BRAIDED BRAKE LINE KIT (SINGLE REAR)		79	7" 2WD / 4WD
84927	2008-2013	FRONT / REAR STEEL BRAIDED BRAKE LINE KIT (DUAL REAR)		79	7" 2WD / 4WD
84943	2007-2013	HEAVY DUTY HEIMS JOINT STEERING CONVERSION KIT		19, 22, 23	7" 2WD / 4WD
84948	2007-2013	DOUBLE FRONT STEERING STABILIZER KIT W/ BASIC HYDRAULIC STABILIZERS		56	7" 2WD / 4WD
84949	2007-2013	DOUBLE FRONT STEERING STABILIZER KIT W/ FTS 2.0 CHROME STABILIZERS		30, 56	7" 2WD / 4WD
84948	2007-2013	DOUBLE FRONT STEERING STABILIZER KIT W/ FTS 2.0 BLACK STABILIZERS		31, 56	7" 2WD / 4WD
85060	2007-2013	REAR TUBULAR LOWER TRAILING ARMS		69	7" 2WD / 4WD
85061	2007-2013	REAR TUBULAR TRACK BARS		68	7" 2WD / 4WD
CVDL36	2007-2013	CV FRONT DRIVE SHAFT 36"		35	7" AWD

10" 2007 - 2013 CHEVY / GMC 1500

Complete drop down kit and 100% bolt on

Front differential is dropped a full 10" to maintain proper CV axle angles
Impact struts to distribute front suspension impact loads through frame
Steering rack is dropped a full 10" to maintain proper tie rod angles

Utilizes the factory front bump stops for superior ride quality

Designed to work with factory stabiltrack and AWD models

Semi Gloss black powder-coat for a long lasting great look

Basic kit includes Front and Rear steel braided brake lines

No cutting on front differential or factory bump stops

Cross-member are constructed of 1/4" thick steel

Lifetime Warranty against manufactures defects

4WD kits includes CV front drive shaft

10" Rear springs included in the kit



Basic 2WD kit includes:

- 10" Front Box Kit
- 10" Rear Springs
- Front / Rear Steel Braided Brake Lines

Basic 4WD / AWD kit includes:

- 10" Front Box Kit
- 10" Rear Springs
- Cv Front Drive Shaft
- Front / Rear Steel Braided Brake Lines

Shocks Sold Separately.

Please see options below

Max Recommended Tire Size 37"

Max Recommended Wheel Width 12"

2WD SILVERADO / SIERRA 1500 BASIC KIT
Part # 84801.

4WD SILVERADO / SIERRA 1500 BASIC KIT
Part # 84802

4WD SILVERADO / SIERRA 1500 W/ COILOVERS
Part # 84814



PART #	YEAR	TITLE	FOOTNOTES	LIFT SIZE	2WD / 4WD
10" 2007-2013 CHEVY / GMC SILVERADO / SIERRA 1500					
84801	2007	SILVERADO / SIERRA 1500 BASIC KIT	2, 19, 99	10"	2WD
84811	2007	SILVERADO / SIERRA 1500 W/ COILOVERS	2, 19, 99	10"	2WD
84802	2007	SILVERADO / SIERRA 1500 BASIC KIT	1, 19, 99	10"	4WD
84812	2007	SILVERADO / SIERRA 1500 W/ COILOVERS	1, 19, 99	10"	4WD
84810	2008-2013	SILVERADO / SIERRA 1500 BASIC KIT	2, 19, 99	10"	2WD
84813	2008-2013	SILVERADO / SIERRA 1500 W/ COILOVERS	2, 19, 99	10"	2WD
84820	2008-2013	SILVERADO / SIERRA 1500 BASIC KIT	1, 19, 99	10"	4WD
84814	2008-2013	SILVERADO / SIERRA 1500 W/ COILOVERS	1, 19, 99	10"	4WD
DOUBLE FRONT SHOCK UPGRADE					
84840	2007-2013	DOUBLE FRONT HOOPS W/ UNI BALL UPPER A ARMS	27, 40, 41	10"	2WD / 4WD
84845	2007-2013	DOUBLE FRONT HOOPS W/ BALL JOINT UPPER A ARMS	27	10"	2WD / 4WD
84841	2007-2013	DOUBLE FRONT HOOPS W/ UPPER A ARMS BRACKETS	27	10"	2WD / 4WD
84842	2007-2013	UNI BALL UPPER A ARMS	40, 41	10"	2WD / 4WD
84846	2007-2013	BALL JOINT UPPER A ARMS	41	10"	2WD / 4WD
C2085-625R	2007-2013	FTS 2.0 REMOTE RESERVOIR 8.5" TRAVEL CHROME FINISH (DOUBLE FRONT SHOCK)	29, 30	10"	2WD / 4WD
B2085-625R	2007-2013	FTS 2.0 REMOTE RESERVOIR 8.5" TRAVEL BLACK FINISH (DOUBLE FRONT SHOCK)	29, 31	10"	2WD / 4WD
FRONT COIL OVER SHOCKS COMPLETE					
C8400-7E	2007-2013	FTS 2.5 EMULSION COILOVER SHOCK COMPLETE W/ COILS, MOUNTING BRACKETS	10, 33	10"	2WD / 4WD
C8400-7R	2007-2013	FTS 2.5 REMOTE RESERVOIR COILOVER SHOCK COMPLETE W/ COILS, MOUNTING BRACKETS	10, 33, 57	10"	2WD / 4WD
SINGLE REAR SHOCK STOCK LOCATION					
C2014-625R	2007-2013	FTS 2.0 REMOTE RESERVOIR 14" TRAVEL CHROME FINISH (STOCK REAR LOCATION)	29, 30	10"	2WD / 4WD
B2014-625R	2007-2013	FTS 2.0 REMOTE RESERVOIR 14" TRAVEL BLACK FINISH (STOCK REAR LOCATION)	29, 31	10"	2WD / 4WD
DOUBLE REAR SHOCK BRACKET					
85049	2007-2013	DOUBLE REAR SHOCK BRACKET KIT *REQUIRES 10" TRAVEL SHOCKS	12, 18, 27	10"	2WD / 4WD
B2010-625R	2007-2013	FTS 2.0 REMOTE RESERVOIR 10" TRAVEL BLACK FINISH	29, 30	10"	2WD / 4WD
C2010-625R	2007-2013	FTS 2.0 REMOTE RESERVOIR 10" TRAVEL CHROME FINISH	29, 31	10"	2WD / 4WD
BILLET SHOCK CLAMPS					
C2020	2007-2013	FTS 2.0 TO 2.0 BILLET SHOCK CLAMPS CHROME FINISH	38	10"	2WD / 4WD
B2020	2007-2013	FTS 2.0 TO 2.0 BILLET SHOCK CLAMPS BLACK FINISH	38	10"	2WD / 4WD
ACCESSORIES					
84826	2007-2008	FRONT / REAR STEEL BRAIDED BRAKE LINE KIT (SINGLE REAR)	79	10"	2WD / 4WD
84827	2008-2013	FRONT / REAR STEEL BRAIDED BRAKE LINE KIT (DUAL REAR)	79	10"	2WD / 4WD
84877	2007-2013	2.5 FRONT COILOVER BRACKETS (UPPER / LOWER)	17, 56	10"	2WD/4WD
84843	2007-2013	HEAVY DUTY HEIMS JOINT STEERING CONVERSION KIT	19, 22, 23	10"	2WD / 4WD
85446	2007-2013	DOUBLE FRONT STEERING STABILIZER KIT W/ BASIC HYDRAULIC STABILIZERS	56	10"	2WD / 4WD
85448	2007-2013	DOUBLE FRONT STEERING STABILIZER KIT W/ FTS 2.0 CHROME STABILIZERS	30, 56	10"	2WD / 4WD
85449	2007-2013	DOUBLE FRONT STEERING STABILIZER KIT W/ FTS 2.0 BLACK STABILIZERS	31, 56	10"	2WD / 4WD
1350	2007-2013	2" REAR DRIVE LINE SPACER 1350 SERIES	59, 60	10"	2WD / 4WD
13963	2007-2013	BOLT ON TRACTION BAR KIT 63" (SHORT BED)	27, 56, 58	10"	2WD / 4WD
13970	2007-2013	BOLT ON TRACTION BAR KIT 70" (LONG BED)	27, 56, 58	10"	2WD / 4WD
84850	2007-2013	REAR AIR BAG KIT (USE W/ STOCK SPRINGS)	56	10"	2WD / 4WD
84851	2007-2013	REAR AIR BAG KIT (USE W/ FTS 10" SPRINGS)	27, 56	10"	2WD / 4WD
C10	2007-2013	10" REAR LEAF SPRINGS	55	10"	2WD / 4WD
CVDL37	2007-2013	CV FRONT DRIVE SHAFT 37"	35	10"	4WD
B426	2007-2013	REPLACEMENT UPPER BALL JOINT (PRESS IN)		10"	2WD / 4WD

Part# 84841



Part# 84842



Part# 84843

Part# 84826



Part# 13963



Part# 84850

BASIC SHOCKS

Rear Shock Stock Location	132000
Double Front Shock	124500
Double Rear Shock	126500

10" 2007 - 2013 CHEVY / GMC / CADILLAC 1500 SUV

10" CHEVY / GMC 1500 SUV 2007-2013

Complete drop down kit and 100% bolt on
 Front differential is dropped a full 10" to maintain proper CV axle angles
 Impact struts to distribute front suspension impact loads through frame
 Steering rack is dropped a full 10" to maintain proper tie rod angles
 Utilizes the factory front bump stops for superior ride quality
 Designed to work with factory stabilizer and AWD models
 Semi Gloss black powder-coat for a long lasting great look
 Basic kit includes Front and Rear steel braided brake lines
 No cutting on front differential or factory bump stops
 Cross-member are constructed of 1/4" thick steel
 Lifetime Warranty against manufactures defects
 Rear kit utilizes factory coils for stock ride
 4WD kits includes CV front drive shaft
 No exhaust modification required
 No wheel restrictions



Basic 2WD kit includes:
 10" Front Box Kit
 10" Rear Kit
 Front / Rear Steel Braided Brake Lines
 Basic 4WD / AWD kit includes:
 10" Front Box Kit
 10" Rear Kit
 Cv Front Drive Shaft
 Front / Rear Steel Braided Brake Lines
 Shocks Sold Separately,
 Please see options below

Max Recommended Tire Size 37"
 Max Recommended Wheel Width 12"

4WD TAHOE / SUBURBAN / AVALANCHE / YUKON
 ESCALADE / DENALI 1500 BASIC KIT Part # 84805

4WD TAHOE / SUBURBAN / AVALANCHE / YUKON
 ESCALADE / DENALI 1500 W/ COILOVERS Part # 84816

2WD TAHOE / SUBURBAN / AVALANCHE / YUKON
 ESCALADE / DENALI 1500 BASIC KIT Part # 84804



10" 2007-2013 CHEVY / GMC SUV REAR KIT



Part# B2012-625R



Part# C8400-7R



Part# C8400-7E



Part# 85061



PART #	YEAR	TITLE	FOOTNOTES	LIFT SIZE	2WD / 4WD
10" 2007-2013 CHEVY / GMC TAHOE / SUBURBAN / AVALANCHE / YUKON / ESCALADE / DENALI 1500					
84803	2007	TAHOE / SUBURBAN / AVALANCHE / YUKON / ESCALADE / DENALI 1500 BASIC KIT	9, 97, 99	10"	2WD
84804	2008-2013	TAHOE / SUBURBAN / AVALANCHE / YUKON / ESCALADE / DENALI 1500 BASIC KIT	9, 97, 99	10"	2WD
84807	2007	TAHOE / SUBURBAN / AVALANCHE / YUKON / ESCALADE / DENALI 1500 W/ COILOVERS	9, 97, 99	10"	2WD
84815	2008-2013	TAHOE / SUBURBAN / AVALANCHE / YUKON / ESCALADE / DENALI 1500 W/ COILOVERS	9, 97, 99	10"	2WD
84805	2007	TAHOE / SUBURBAN / AVALANCHE / YUKON / ESCALADE / DENALI 1500 BASIC KIT	7, 97, 99	10"	4WD
84806	2008-2013	TAHOE / SUBURBAN / AVALANCHE / YUKON / ESCALADE / DENALI 1500 BASIC KIT	7, 97, 99	10"	4WD
84808	2007	TAHOE / SUBURBAN / AVALANCHE / YUKON / ESCALADE / DENALI 1500 W/ COILOVERS	7, 97, 99	10"	4WD
84816	2008-2013	TAHOE / SUBURBAN / AVALANCHE / YUKON / ESCALADE / DENALI 1500 W/ COILOVERS	7, 97, 99	10"	4WD
DOUBLE FRONT SHOCK UPGRADE					
84840	2007-2013	DOUBLE FRONT HOOPS W/ UNI BALL UPPER A ARMS	27, 40, 41	10"	2WD / 4WD
84845	2007-2013	DOUBLE FRONT HOOPS W/ BALL JOINT UPPER A ARMS	27	10"	2WD / 4WD
84841	2007-2013	DOUBLE FRONT HOOPS W/ UPPER A ARMS BRACKETS	27	10"	2WD / 4WD
84842	2007-2013	UNI BALL UPPER A ARMS	40, 41	10"	2WD / 4WD
84846	2007-2013	BALL JOINT UPPER A ARMS	41	10"	2WD / 4WD
C2085-625R	2007-2013	FTS 2.0 REMOTE RESERVOIR 8.5" TRAVEL CHROME FINISH (DOUBLE FRONT SHOCK)	29, 30	10"	2WD / 4WD
B2085-625R	2007-2013	FTS 2.0 REMOTE RESERVOIR 8.5" TRAVEL BLACK FINISH (DOUBLE FRONT SHOCK)	29, 31	10"	2WD / 4WD
FRONT COIL OVER SHOCKS COMPLETE					
C8400-7E	2007-2013	FTS 2.5 EMULSION COILOVER SHOCK COMPLETE W/ COILS, MOUNTING BRACKETS	10, 33	10"	2WD / 4WD
C8400-7R	2007-2013	FTS 2.5 REMOTE RESERVOIR COILOVER SHOCK COMPLETE W/ COILS, MOUNTING BRACKETS	10, 33, 57	10"	2WD / 4WD
SINGLE REAR SHOCK STOCK LOCATION					
84823	2007-2013	REAR SHOCK BRACKETS (REQUIRED W/ AUTO RIDE VEHICLES)	24	10"	2WD / 4WD
C2014-625R	2007-2013	FTS 2.0 REMOTE RESERVOIR 14" TRAVEL CHROME FINISH (STOCK REAR LOCATION)	29, 30	10"	2WD / 4WD
B2014-625R	2007-2013	FTS 2.0 REMOTE RESERVOIR 14" TRAVEL BLACK FINISH (STOCK REAR LOCATION)	29, 31	10"	2WD / 4WD
BILLET SHOCK CLAMPS					
C2020	2007-2013	FTS 2.0 TO 2.0 BILLET SHOCK CLAMPS CHROME FINISH	38	10"	2WD / 4WD
B2020	2007-2013	FTS 2.0 TO 2.0 BILLET SHOCK CLAMPS BLACK FINISH	38	10"	2WD / 4WD
ACCESSORIES					
84826	2007-2008	FRONT / REAR STEEL BRAIDED BRAKE LINE KIT (SINGLE REAR)	79	10"	2WD / 4WD
84827	2008-2013	FRONT / REAR STEEL BRAIDED BRAKE LINE KIT (DUAL REAR)	79	10"	2WD / 4WD
84877	2007-2013	2.5 FRONT COILOVER BRACKETS (UPPER / LOWER)	17, 56	10"	2WD / 4WD
84843	2007-2013	HEAVY DUTY HEIMS JOINT STEERING CONVERSION KIT	19, 22, 23	10"	2WD / 4WD
85446	2007-2013	DOUBLE FRONT STEERING STABILIZER KIT W/ BASIC HYDRAULIC STABILIZERS	56	10"	2WD / 4WD
85448	2007-2013	DOUBLE FRONT STEERING STABILIZER KIT W/ FTS 2.0 CHROME STABILIZERS	30, 56	10"	2WD / 4WD
85449	2007-2013	DOUBLE FRONT STEERING STABILIZER KIT W/ FTS 2.0 BLACK STABILIZERS	31, 56	10"	2WD / 4WD
1350	2007-2013	2" REAR DRIVE LINE SPACER 1350 SERIES	59, 60	10"	2WD / 4WD
85060	2007-2013	REAR TUBULAR LOWER TRAILING ARMS	69	10"	2WD / 4WD
85061	2007-2013	REAR TUBULAR TRACK BAR	68	10"	2WD / 4WD
CVDL37	2007-2013	CV FRONT DRIVE SHAFT 37"	35	10"	4WD
B426	2007-2013	REPLACEMENT UPPER BALL JOINT (PRESS IN)		10"	2WD / 4WD

15" 2007 - 2013 CHEVY / GMC 1500

Complete drop down kit and 100% bolt on

- Front differential is dropped a full 15" to maintain proper CV axle angles
- Impact struts to distribute front suspension impact loads through frame
- Steering rack is dropped a full 15" to maintain proper tie rod angles
- Utilizes the factory front bump stops for superior ride quality
- Designed to work with factory stabiltrack and AWD models
- Semi Gloss black powder coat for a long lasting great look
- Basic kit includes Front and Rear steel braided brake lines
- No cutting on front differential or factory bump stops
- Cross-member are constructed of 1/4" thick steel
- Lifetime Warranty against manufactures defects
- 4WD kits includes CV front drive shaft
- No exhaust modification required



- Basic 2WD kit includes:**
- 15" Front Box Kit
 - 12" Rear Springs & 4" Rear Block Kit
 - Front / Rear Steel Braided Brake Lines
 - Rear Drive Shaft Spacer
- Basic 4WD / AWD kit includes:**
- 15" Front Box Kit
 - 12" Rear Springs & 4" Rear Block Kit
 - Cv Front Drive Shaft
 - Front / Rear Steel Braided Brake Lines
 - Rear Drive Shaft Spacer
- Shocks Sold Separately.**
Please see options below
- Max Recommended Tire Size 40"
 - Max Recommended Wheel Width 12"

2WD SILVERADO / SIERRA 1500 BASIC KIT
Part # 84721

4WD SILVERADO / SIERRA 1500 BASIC KIT
Part # 84722

SILVERADO / SIERRA 1500 W/ COIL OVERS
Part # 84732



PART #	YEAR	TITLE	FOOTNOTES	LIFT SIZE	2WD / 4WD
15" 2007-2013 CHEVY / GMC SILVERADO / SIERRA 1500					
84701	2007	SILVERADO / SIERRA 1500 BASIC KIT	21, 99	15"	2WD
84711	2007	SILVERADO / SIERRA 1500 W/ COILOVERS	21, 99	15"	2WD
84702	2007	SILVERADO / SIERRA 1500 BASIC KIT	20, 99	15"	4WD
84712	2007	SILVERADO / SIERRA 1500 W/ COILOVERS	20, 99	15"	4WD
84721	2008-2013	SILVERADO / SIERRA 1500 BASIC KIT	21, 99	15"	2WD
84731	2008-2013	SILVERADO / SIERRA 1500 W/ COILOVERS	21, 99	15"	2WD
84722	2008-2013	SILVERADO / SIERRA 1500 BASIC KIT	20, 99	15"	4WD
84732	2008-2013	SILVERADO / SIERRA 1500 W/ COILOVERS	20, 99	15"	4WD
DOUBLE FRONT SHOCK UPGRADE					
84840	2007-2013	DOUBLE FRONT HOOPS W/ UNI BALL UPPER A ARMS	27, 40, 41	15"	2WD / 4WD
84845	2007-2013	DOUBLE FRONT HOOPS W/ BALL JOINT UPPER A ARMS	27	15"	2WD / 4WD
84841	2007-2013	DOUBLE FRONT HOOPS W/ UPPER A ARMS BRACKETS	27	15"	2WD / 4WD
84842	2007-2013	UNI BALL UPPER A ARMS	40, 41	15"	2WD / 4WD
84846	2007-2013	BALL JOINT UPPER A ARMS	41	15"	2WD / 4WD
C2012-625R	2007-2013	FTS 2.0 REMOTE RESERVOIR 12" TRAVEL CHROME FINISH (DOUBLE FRONT SHOCK)	29, 30	15"	2WD / 4WD
B2012-625R	2007-2013	FTS 2.0 REMOTE RESERVOIR 12" TRAVEL BLACK FINISH (DOUBLE FRONT SHOCK)	29, 31	15"	2WD / 4WD
FRONT COIL OVER SHOCKS COMPLETE					
C8470-7E	2007-2013	FTS 2.5 EMULSION COILOVER SHOCK COMPLETE W/ COILS, MOUNTING BRACKETS	10, 33	15"	2WD / 4WD
C8470-7R	2007-2013	FTS 2.5 REMOTE RESERVOIR COILOVER SHOCK COMPLETE W/ COILS, MOUNTING BRACKETS	10, 33, 57	15"	2WD / 4WD
SINGLE REAR SHOCK STOCK LOCATION					
C2016-875R	2007-2013	FTS 2.0 REMOTE RESERVOIR 12" TRAVEL CHROME FINISH (STOCK REAR LOCATION)	29, 30, 54	15"	2WD / 4WD
B2016-875R	2007-2013	FTS 2.0 REMOTE RESERVOIR 16" TRAVEL BLACK FINISH (STOCK REAR LOCATION)	29, 31, 54	15"	2WD / 4WD
DOUBLE REAR SHOCK BRACKET					
85049	2007-2013	DOUBLE REAR SHOCK BRACKET KIT (REQUIRES 11" TRAVEL SHOCKS)	12, 18, 27	15"	2WD / 4WD
C2011-625R	2007-2013	FTS 2.0 REMOTE RESERVOIR 11" TRAVEL CHROME FINISH (DOUBLE REAR SHOCK)	29, 30	15"	2WD / 4WD
B2011-625R	2007-2013	FTS 2.0 REMOTE RESERVOIR 11" TRAVEL BLACK FINISH (DOUBLE REAR SHOCK)	29, 31	15"	2WD / 4WD
BILLET SHOCK CLAMPS					
C2020	2007-2013	FTS 2.0 TO 2.0 BILLET SHOCK CLAMPS CHROME FINISH	38	15"	2WD / 4WD
B2020	2007-2013	FTS 2.0 TO 2.0 BILLET SHOCK CLAMPS BLACK FINISH	38	15"	2WD / 4WD
ACCESSORIES					
84726	2007-2008	FRONT / REAR STEEL BRAIDED BRAKE LINE KIT (SINGLE REAR)	79	15"	2WD / 4WD
84727	2008-2013	FRONT / REAR STEEL BRAIDED BRAKE LINE KIT (DUAL REAR)	79	15"	2WD / 4WD
84877	2007-2013	2.5 FRONT COILOVER BRACKETS (UPPER / LOWER)	17, 56	15"	2WD / 4WD
84843	2007-2013	HEAVY DUTY HEIMS JOINT STEERING CONVERSION KIT	19, 22, 23	15"	2WD / 4WD
85446	2007-2013	DOUBLE FRONT STEERING STABILIZER KIT W/ BASIC HYDRAULIC STABILIZERS	56	15"	2WD / 4WD
85448	2007-2013	DOUBLE FRONT STEERING STABILIZER KIT W/ FTS 2.0 CHROME STABILIZERS	30, 56	15"	2WD / 4WD
85449	2007-2013	DOUBLE FRONT STEERING STABILIZER KIT W/ FTS 2.0 BLACK STABILIZERS	31, 56	15"	2WD / 4WD
13968	2007-2013	BOLT ON TRACTION BAR KIT 68" (SHORT BED)	27, 56, 58	15"	2WD / 4WD
13974	2007-2013	BOLT ON TRACTION BAR KIT 74" (LONG BED)	27, 56, 58	15"	2WD / 4WD
19968	2007-2013	WELD ON TRACTION BAR KIT 68" (SHORT BED)	18	15"	2WD / 4WD
19978	2007-2013	WELD ON TRACTION BAR KIT 78" (LONG BED)	18	15"	2WD / 4WD
84851	2007-2013	REAR AIR BAG KIT (USE W/ FTS 12" SPRINGS)	27, 56	15"	2WD / 4WD
C12	2007-2013	12" REAR LEAF SPRINGS	55	15"	2WD / 4WD
CVDL38	2007-2013	CV FRONT DRIVE SHAFT 38"	35	15"	4WD
CBK25-400T	2007-2013	4.00" TAPERED REAR BLOCK KIT W/ 9/16" X 2.5" X 14" SQUARE U BOLTS	58	15"	2WD / 4WD
1350	2007-2013	REAR DRIVE SHAFT SPACER 1350 SERIES U JOINT	59, 60	15"	2WD / 4WD
8426	2007-2013	REPLACEMENT UPPER BALL JOINT (PRESS IN)	19,81	15"	2WD / 4WD
U601	2007-2013	REPLACEMENT UPPER UNI-BALLS W/ SNAP RING (SOLD IN PAIRS)	19	15"	2WD / 4WD



BASIC SHOCKS

Double Front Shocks	132000
Double Rear Shocks	129500

15" 2007 - 2013 CHEVY / GMC / CADILLAC 1500 SUV

15" INCH
2007-2013
CHEVY / GMC
1500 SUV

Complete drop down kit and 100% bolt on
New long arm rear suspension links provide superior look and ride quality
Front differential is dropped a full 15" to maintain proper CV axle angles
Impact struts to distribute front suspension impact loads through frame
Steering rack is dropped a full 15" to maintain proper tie rod angles
Utilizes the factory front bump stops for superior ride quality
Designed to work with factory stabilizer and AWD models
Semi Gloss black powder-coat for a long lasting great look
Basic kit includes Front and Rear steel braided brake lines
No cutting on front differential or factory bump stops
Cross-member are constructed of 1/4" thick steel
Lifetime Warranty against manufactures defects
4WD / AWD kits includes CV front drive shaft
Rear kit utilizes factory coils for stock ride
No exhaust modification required
No wheel restrictions
Max Recommended Tire Size 40"
Max Recommended Wheel Width 12"



Basic 2WD kit includes:
15" Front Box Kit
15" Rear Kit
Front / Rear Steel Braided Brake Lines
Rear Drive Shaft Spacer

Basic 4WD / AWD kit includes:
15" Front Box Kit
15" Rear Kit
CV Front Drive Shaft
Front / Rear Steel Braided Brake Lines
Rear Drive Shaft Spacer

Shocks Sold Separately.
Please see options below

4WD TAHOE / SUBURBAN / AVALANCHE / YUKON
ESCALADE / DENALI 1500 BASIC KIT Part # 84706

4WD TAHOE / SUBURBAN / AVALANCHE / YUKON
ESCALADE / DENALI 1500 W/ COILOVERS Part # 84709

2WD TAHOE / SUBURBAN / AVALANCHE / YUKON
ESCALADE / DENALI 1500 BASIC KIT Part # 84704



15" 2007-2013 CHEVY / GMC SUV REAR KIT



Part# C8470-7E



Part# C8470-7R

PART #	YEAR	TITLE	FOOTNOTES	LIFT SIZE	2WD / 4WD
15" 2007-2013 TAHOE / SUBURBAN / AVALANCHE / YUKON / ESCALADE / DENALI 1500					
84703	2007	TAHOE / SUBURBAN/AVALANCHE/YUKON/ESCALADE/DENALI 1500 BASIC KIT	36, 97, 99	15"	2WD
84704	2008-2013	TAHOE / SUBURBAN/AVALANCHE/YUKON/ESCALADE/DENALI 1500 BASIC KIT	36, 97, 99	15"	2WD
84707	2007	TAHOE / SUBURBAN/AVALANCHE/YUKON/ESCALADE/DENALI 1500 W/ COILOVERS	36, 97, 99	15"	2WD
84710	2008-2013	TAHOE / SUBURBAN/AVALANCHE/YUKON/ESCALADE/DENALI 1500 W/ COILOVERS	36, 97, 99	15"	2WD
84705	2007	TAHOE / SUBURBAN/AVALANCHE/YUKON/ESCALADE/DENALI 1500 BASIC KIT	28, 32, 97, 99	15"	4WD
84706	2008-2013	TAHOE / SUBURBAN/AVALANCHE/YUKON/ESCALADE/DENALI 1500 BASIC KIT	28, 32, 97, 99	15"	4WD
84708	2007	TAHOE / SUBURBAN/AVALANCHE/YUKON/ESCALADE/DENALI 1500 W/ COILOVERS	28, 32, 97, 99	15"	4WD
84709	2008-2013	TAHOE / SUBURBAN/AVALANCHE/YUKON/ESCALADE/DENALI 1500 W/ COILOVERS	28, 32, 97, 99	15"	4WD
DOUBLE FRONT SHOCK UPGRADE					
84840	2007-2013	DOUBLE FRONT HOOPS W/ UNI BALL UPPER A ARMS	27, 40, 41	15"	2WD / 4WD
84845	2007-2013	DOUBLE FRONT HOOPS W/ BALL JOINT UPPER A ARMS	27	15"	2WD / 4WD
84841	2007-2013	DOUBLE FRONT HOOPS W/ UPPER A ARMS BRACKETS	27	15"	2WD / 4WD
84842	2007-2013	UNI BALL UPPER A ARMS	40, 41	15"	2WD / 4WD
84846	2007-2013	BALL JOINT UPPER A ARMS	41	15"	2WD / 4WD
C2012-625R	2007-2013	FTS 2.0 REMOTE RESERVOIR 12" TRAVEL CHROME FINISH (DOUBLE FRONT SHOCK)	29, 30	15"	2WD / 4WD
B2012-625R	2007-2013	FTS 2.0 REMOTE RESERVOIR 12" TRAVEL BLACK FINISH (DOUBLE FRONT SHOCK)	29, 31	15"	2WD / 4WD
FRONT COIL OVER SHOCKS COMPLETE					
C8470-7E	2007-2013	FTS 2.5 EMULSION COILOVER SHOCK COMPLETE W/ COILS, MOUNTING BRACKETS	10, 33	15"	2WD / 4WD
C8470-7R	2007-2013	FTS 2.5 REMOTE RESERVOIR COILOVER SHOCK COMPLETE W/ COILS, MOUNTING BRACKETS	10, 33, 57	15"	2WD / 4WD
SINGLE REAR SHOCK STOCK LOCATION					
84723	2007-2013	REAR SHOCK BRACKETS (REQUIRED W/ AUTO RIDE VEHICLES)	29, 30, 54	15"	2WD / 4WD
C2016-875R	2007-2013	FTS 2.0 REMOTE RESERVOIR 16" TRAVEL CHROME FINISH (STOCK REAR LOCATION)	29, 30, 54	15"	2WD / 4WD
B2016-875R	2007-2013	FTS 2.0 REMOTE RESERVOIR 16" TRAVEL BLACK FINISH (STOCK REAR LOCATION)	29, 31, 54	15"	2WD / 4WD
BILLET SHOCK CLAMPS					
C2020	2007-2013	FTS 2.0 TO 2.0 BILLET SHOCK CLAMPS BLACK FINISH	38	15"	2WD / 4WD
B2020	2007-2013	FTS 2.0 TO 2.0 BILLET SHOCK CLAMPS BLACK FINISH	38	15"	2WD / 4WD
ACCESSORIES					
84726	2007-2008	FRONT / REAR STEEL BRAIDED BRAKE LINE KIT (SINGLE REAR)	79	15"	2WD / 4WD
84727	2008-2013	FRONT / REAR STEEL BRAIDED BRAKE LINE KIT (DUAL REAR)	79	15"	2WD / 4WD
84877	2007-2013	2.5 FRONT COILOVER BRACKETS (UPPER / LOWER)	17, 56	15"	2WD / 4WD
84843	2007-2013	HEAVY DUTY HEIMS JOINT STEERING CONVERSION KIT	19, 22, 23	15"	2WD / 4WD
85446	2007-2013	DOUBLE FRONT STEERING STABILIZER KIT W/ BASIC HYDRAULIC STABILIZERS	56	15"	2WD / 4WD
85448	2007-2013	DOUBLE FRONT STEERING STABILIZER KIT W/ FTS 2.0 CHROME STABILIZERS	30, 56	15"	2WD / 4WD
85449	2007-2013	DOUBLE FRONT STEERING STABILIZER KIT W/ FTS 2.0 BLACK STABILIZERS	31, 56	15"	2WD / 4WD
85060	2007-2013	REAR TUBULAR LOWER TRAILING ARMS	69	15"	2WD / 4WD
85061	2007-2013	REAR TUBULAR TRACK BAR	68	15"	2WD / 4WD
CVDL38	2007-2013	CV FRONT DRIVE SHAFT 38"	35	15"	4WD
1350	2007-2013	REAR DRIVE SHAFT SPACER 1350 SERIES U JOINT	59, 60	15"	2WD / 4WD
B426	2007-2013	REPLACEMENT UPPER BALL JOINT (PRESS IN)	19, 48	15"	2WD / 4WD
U601	2007-2013	REPLACEMENT UPPER UNI-BALLS W/ SNAP RING (SOLD IN PAIRS)	19	15"	2WD / 4WD

7" 2000 - 2010 CHEVY / GMC 1500HD / 2500HD / 3500HD

100% Bolt On - Spindle kit that DOES NOT extended the track width
 Front differential is dropped a full 7" to maintain proper CV axle angles
 Impact struts to distribute front suspension impact loads through frame
 No rear add a leaf makes for easy installation and factory ride quality
 Utilizes the factory front bump stops for superior ride quality
 Semi Gloss black powder-coat for a long lasting great look
 Fabricated Steel Blocks (Non Casted) w/ Grade 8 U Bolts
 No cutting on front differential or factory bump stops
 Cross-members are constructed of 1/4" thick steel
 Lifetime Warranty against manufactures defects
 No front drive shaft required on Duramax models
 No exhaust modification required



Max Recommended Tire Size 35"
 Max Recommended Wheel Width 12"
 Max Recommended Tire Size 37"
 Max Recommended Wheel Width 10"
 Required 17" or larger Wheel with
 no more than 5" Backspace

4WD SILVERADO / SIERRA HD W/ REAR BLOCKS
 Part # 85102

4WD SILVERADO / SIERRA HD W/ REAR SPRING
 Part # 85112

Basic 2WD kit includes:
 7" Front Box Kit
 LH / RH Steering Knuckles
 5.25" Rear Block Kit (Optional Spring Upgrade)

Basic 4WD kit includes:
 7" Front Box Kit
 LH / RH Steering Knuckles
 5.25" Rear Block Kit (Optional Spring Upgrade)

Shocks Sold Separately.
 Please see options below



PART #	YEAR	TITLE	FOOTNOTES	LIFT SIZE	2WD / 4WD
7" 2000-2010 CHEVY / GMC SILVERADO / SIERRA 1500HD / 2500HD / 3500HD DIESEL					
85101	2001-2010	SILVERADO / SIERRA 1500HD / 2500HD NON DUALY W/ REAR BLOCKS	4, 27, 52	7"	2WD
85111	2001-2010	SILVERADO / SIERRA 1500HD / 2500HD NON DUALY W/ REAR 7" SPRINGS	4, 27, 52	7"	2WD
85102	2001-2010	SILVERADO / SIERRA 1500HD / 2500HD NON DUALY W/ REAR BLOCKS	4, 27, 52	7"	4WD
85112	2001-2010	SILVERADO / SIERRA 1500HD / 2500HD NON DUALY W/ REAR 7" SPRINGS	4, 27, 52	7"	4WD
85103	2001-2010	SILVERADO 3500HD / 3500HD DUALY W/ REAR BLOCKS	4, 27, 52	7"	2WD
85104	2001-2010	SILVERADO 3500HD / 3500HD DUALY W/ REAR BLOCKS	4, 27, 52	7"	4WD
7" 1999-2000 CHEVY / GMC SILVERADO / SIERRA 2500					
85109	1999-2000	SILVERADO / SIERRA 2500 NON DUALY W/ REAR BLOCKS (GAS 6.0)	19, 52	7"	4WD
85119	1999-2000	SILVERADO / SIERRA 2500 NON DUALY W/ REAR 7" SPRINGS (GAS 6.0)	19, 52	7"	4WD
DOUBLE FRONT SHOCK UPGRADE					
85048	1999-2010	DOUBLE FRONT HOOPS W/ UNI BALL UPPER A ARMS	27, 40, 41	7"	2WD / 4WD
85042	1999-2010	DOUBLE FRONT HOOPS W/ BALL JOINT UPPER A ARMS	27, 41	7"	2WD / 4WD
85040	1999-2010	DOUBLE FRONT HOOPS W/ UPPER A ARMS BRACKETS	27	7"	2WD / 4WD
85047	1999-2010	UNI BALL UPPER A ARMS	40, 41	7"	2WD / 4WD
85041	1999-2010	BALL JOINT UPPER A ARMS	41	7"	2WD / 4WD
C2065-625R	1999-2010	FTS 2.0 REMOTE RESERVOIR 6.5" TRAVEL CHROME FINISH (DOUBLE FRONT SHOCK)	29, 30	7"	2WD / 4WD
B2065-625R	1999-2010	FTS 2.0 REMOTE RESERVOIR 6.5" TRAVEL BLACK FINISH (DOUBLE FRONT SHOCK)	29, 31	7"	2WD / 4WD
SINGLE FRONT SHOCK STOCK LOCATION					
C2085-625RS	1999-2010	FTS 2.0 REMOTE RESERVOIR 8.5" TRAVEL CHROME FINISH (STOCK FRONT LOCATION)	29, 30	7"	2WD / 4WD
B2085-625RS	1999-2010	FTS 2.0 REMOTE RESERVOIR 8.5" TRAVEL BLACK FINISH (STOCK FRONT LOCATION)	29, 31	7"	2WD / 4WD
SINGLE REAR SHOCK STOCK LOCATION					
C2012-625R	1999-2010	FTS 2.0 REMOTE RESERVOIR 12" TRAVEL CHROME FINISH (STOCK REAR LOCATION)	29, 30	7"	2WD / 4WD
B2012-625R	1999-2010	FTS 2.0 REMOTE RESERVOIR 12" TRAVEL BLACK FINISH (STOCK REAR LOCATION)	29, 31	7"	2WD / 4WD
DOUBLE REAR SHOCK BRACKET					
85249	1999-2010	DOUBLE REAR SHOCK BRACKET KIT *REQUIRES 8.5" TRAVEL SHOCK	12, 18, 27	7"	2WD / 4WD
C2085-625R	1999-2010	FTS 2.0 REMOTE RESERVOIR 8.5" TRAVEL CHROME FINISH (DOUBLE REAR SHOCK)	29, 31	7"	2WD / 4WD
B2085-625R	1999-2010	FTS 2.0 REMOTE RESERVOIR 8.5" TRAVEL BLACK FINISH (DOUBLE REAR SHOCK)	29, 31	7"	2WD / 4WD
BILLET SHOCK CLAMPS					
C2020	1999-2010	FTS 2.0 TO 2.0 BILLET SHOCK CLAMPS CHROME FINISH	38	7"	2WD / 4WD
B2020	1999-2010	FTS 2.0 TO 2.0 BILLET SHOCK CLAMPS BLACK FINISH	38	7"	2WD / 4WD
ACCESSORIES					
85022	1999-2006	FRONT / REAR STEEL BRAIDED BRAKE LINE KIT (SINGLE REAR)	79	7"	2WD / 4WD
85026	2007-2008	FRONT / REAR STEEL BRAIDED BRAKE LINE KIT (SINGLE REAR)	79	7"	2WD / 4WD
85027	2008-2010	FRONT / REAR STEEL BRAIDED BRAKE LINE KIT (DUAL REAR)	79	7"	2WD / 4WD
85043	1999-2010	HEIMS JOINT STEERING CONVERSION KIT W/ U BRACKETS	38	7"	2WD / 4WD
85044	1999-2010	HEAVY DUTY HEIMS JOINT STEERING W/ STEERING BAR	22, 38	7"	2WD / 4WD
85046	1999-2010	DOUBLE FRONT STEERING STABILIZER KIT W/ BASIC HYDRAULIC STABILIZERS	56	7"	2WD / 4WD
85251	1999-2010	IDLER ARM BRACE HD	18	7"	2WD / 4WD
14963	1999-2010	BOLT ON TRACTION BAR KIT 63" (SHORT BED)	27, 56, 58	7"	2WD / 4WD
14968	1999-2010	BOLT ON TRACTION BAR KIT 68" (LONG BED)	27, 56, 58	7"	2WD / 4WD
19963	1999-2010	WELD ON TRACTION BAR KIT 63" (SHORT BED)	18	7"	2WD / 4WD
19968	1999-2010	WELD ON TRACTION BAR KIT 68" (LONG BED)	18	7"	2WD / 4WD
85050	1999-2010	REAR AIR BAG KIT (USE W/ STOCK SPRINGS)	27, 56	7"	2WD / 4WD
85051	1999-2010	REAR AIR BAG KIT (USE W/ FTS 7" REAR SPRINGS)	27, 56	7"	2WD / 4WD
C7HD	1999-2010	7" REAR LEAF SPRINGS	55	7"	2WD / 4WD
CBK25-400F	1999-2010	4.00" FLAT BLOCK W/ 9/16" X 2.5" X 15.5" SQUARE U BOLTS	22, 25	7"	2WD / 4WD
CBK25-500F	1999-2010	5.00" FLAT BLOCK W/ 9/16" X 2.5" X 15.5" SQUARE U BOLTS	22, 25	7"	2WD / 4WD
CVDL40	1999-2010	CV FRONT DRIVE SHAFT 40"	35, 47	7"	4WD
85999	1999-2010	DIFFERENTIAL EAR REPLACEMENT BRACKET	27, 44, 59	7"	4WD



BASIC SHOCKS

Front Shock Stock Location	124510
Rear Shock Stock Location	132000
Double Front Shock	120500
Double Rear Shock	122500

9.5" 2000 -2010 CHEVY / GMC 1500HD / 2500HD / 3500HD

2000-2010
CHEVY / GMC
1500HD / 2500HD / 3500HD TRUCK

Complete drop down kit and 100% bolt on
Front differential is dropped a full 9.5" to maintain proper CV axle angles
Impact struts to distribute front suspension impact loads through frame
Utilizes the factory front bump stops for superior ride quality
Semi Gloss black powder-coat for a long lasting great look
Basic kit includes Front and Rear steel braided brake lines
No cutting on front differential or factory bump stops
Cross-member are constructed of 1/4" thick steel
Lifetime Warranty against manufactures defects
4WD kits include Front Drive Shaft
No exhaust modification required
No wheel restrictions



4WD SILVERADO / SIERRA 1500HD
2500HD / 3500HD BASIC KIT Part # 85206

2WD SILVERADO / SIERRA 1500HD
2500HD / 3500HD BASIC KIT Part # 85201



Basic 2WD kit includes:
9.5" Front Box Kit
10" Rear Springs
Front / Rear Steel Braided Brake Lines

Basic 4WD kit includes:
9.5" Front Box Kit
10" Rear Springs
CV Front Drive Shaft
Front / Rear Steel Braided Brake Lines

Shocks Sold Separately.
Please see options below.

Max Recommended Tire Size 38"
Max Recommended Wheel Width 12"



Part# 85238

Part# 85999

Part# 85226

Part# 85251

Part# 85250

BASIC SHOCKS

Front Shock Stock Location	129510
Rear Shock Stock Location	132000
Double Front Shock	126500
Double Rear Shock	126500

PART #	YEAR	TITLE	FOOTNOTES	LIFT SIZE	2WD / 4WD
9.5" 2001-2010 CHEVY / GMC SILVERADO / SIERRA 1500HD / 2500HD / 3500HD					
85201	2001-2006	SILVERADO / SIERRA 1500HD / 2500HD / 3500HD BASIC KIT (W/ SINGLE REAR BRAKE LINE)	5, 52	9.5"	2WD
85205	2007-2008	SILVERADO / SIERRA 1500HD / 2500HD / 3500HD BASIC KIT (W/ SINGLE REAR BRAKE LINE)	5, 52	9.5"	2WD
85207	2008-2010	SILVERADO / SIERRA 1500HD / 2500HD / 3500HD BASIC KIT (W/ DUAL REAR BRAKE LINE)	5, 52	9.5"	2WD
85202	2001-2006	SILVERADO / SIERRA 1500HD / 2500HD / 3500HD BASIC KIT (W/ SINGLE REAR BRAKE LINE)	1, 52	9.5"	4WD
85204	2007-2008	SILVERADO / SIERRA 1500HD / 2500HD / 3500HD BASIC KIT (W/ SINGLE REAR BRAKE LINE)	1, 52	9.5"	4WD
85206	2008-2010	SILVERADO / SIERRA 1500HD / 2500HD / 3500HD BASIC KIT (W/DUAL REAR BRAKE LINE)	1, 52	9.5"	4WD
9.5" 1999-2000 CHEVY / GMC SILVERADO / SIERRA 2500					
85209	1999-2000	SILVERADO / SIERRA 2500 NON HD BASIC KIT (W/ SINGLE REAR BRAKE LINE)	1, 52	9.5"	4WD
DOUBLE FRONT SHOCK UPGRADE					
85238	1999-2010	DOUBLE FRONT HOOPS W/ UNI BALL UPPER A ARMS	27, 40, 41	9.5"	2WD / 4WD
85239	1999-2010	DOUBLE FRONT HOOPS W/ BALL JOINT UPPER A ARMS	27, 41	9.5"	2WD / 4WD
85240	1999-2010	DOUBLE FRONT HOOPS W/ UPPER A ARMS BRACKETS	27	9.5"	2WD / 4WD
85242	1999-2010	UNI BALL UPPER A ARMS	40, 41	9.5"	2WD / 4WD
85241	1999-2010	BALL JOINT UPPER A ARMS	41	9.5"	2WD / 4WD
C2010-625R	1999-2010	FTS 2.0 REMOTE RESERVOIR 10" TRAVEL CHROME FINISH (DOUBLE FRONT SHOCK)	29, 30	9.5"	2WD / 4WD
B2010-625R	1999-2010	FTS 2.0 REMOTE RESERVOIR 10" TRAVEL BLACK FINISH (DOUBLE FRONT SHOCK)	29, 31	9.5"	2WD / 4WD
SINGLE FRONT SHOCK STOCK LOCATION					
C2011-625RS	1999-2010	FTS 2.0 REMOTE RESERVOIR 11" TRAVEL CHROME FINISH (STOCK FRONT LOCATION)	29, 30	9.5"	2WD / 4WD
B2011-625RS	1999-2010	FTS 2.0 REMOTE RESERVOIR 11" TRAVEL BLACK FINISH (STOCK FRONT LOCATION)	29, 31	9.5"	2WD / 4WD
SINGLE REAR SHOCK STOCK LOCATION					
C2014-625R	1999-2010	FTS 2.0 REMOTE RESERVOIR 14" TRAVEL CHROME FINISH (STOCK REAR LOCATION)	29, 30	9.5"	2WD / 4WD
B2014-625R	1999-2010	FTS 2.0 REMOTE RESERVOIR 14" TRAVEL BLACK FINISH (STOCK REAR LOCATION)	29, 31	9.5"	2WD / 4WD
DOUBLE REAR SHOCK BRACKET					
85249	1999-2010	DOUBLE REAR SHOCK BRACKET KIT *REQUIRES 10" TRAVEL SHOCK	12, 18, 27	9.5"	2WD / 4WD
C2010-625R	1999-2010	FTS 2.0 TO 2.0 REMOTE RESERVOIR 10" TRAVEL CHROME FINISH (DOUBLE REAR SHOCK)	29, 30	9.5"	2WD / 4WD
B2010-625R	1999-2010	FTS 2.0 TO 2.0 REMOTE RESERVOIR 10" TRAVEL BLACK FINISH (DOUBLE REAR SHOCK)	29, 31	9.5"	2WD / 4WD
BILLET SHOCK CLAMPS					
C2020	1999-2010	FTS 2.0 BILLET SHOCK CLAMPS CHROME FINISH	38	9.5"	2WD / 4WD
B2020	1999-2010	FTS 2.0 BILLET SHOCK CLAMPS BLACK FINISH	38	9.5"	2WD / 4WD
ACCESSORIES					
85222	1999-2006	FRONT / REAR STEEL BRAIDED BRAKE LINE KIT (SINGLE REAR)	79	9.5"	2WD / 4WD
85226	2007-2008	FRONT / REAR STEEL BRAIDED BRAKE LINE KIT (SINGLE REAR)	79	9.5"	2WD / 4WD
85227	2008-2010	FRONT / REAR STEEL BRAIDED BRAKE LINE KIT (DUAL REAR)	79	9.5"	2WD / 4WD
85243	1999-2010	HEAVY DUTY HEIMS JOINT STEERING KIT	19, 22, 23	9.5"	2WD / 4WD
85246	1999-2010	DOUBLE FRONT STEERING STABILIZER KIT W/ BASIC HYDRAULIC STABILIZERS	56	9.5"	2WD / 4WD
85147	1999-2010	DOUBLE FRONT STEERING STABILIZER KIT W/ FTS 2.0 CHROME STABILIZERS	56	9.5"	2WD / 4WD
85148	1999-2010	DOUBLE FRONT STEERING STABILIZER KIT W/ FTS 2.0 BLACK STABILIZERS	56	9.5"	2WD / 4WD
85251	1999-2010	IDLER ARM BRACE HD	18	9.5"	2WD / 4WD
14963	1999-2010	BOLT ON TRACTION BAR KIT 63" (SHORT BED)	27, 56, 58	9.5"	2WD / 4WD
14968	1999-2010	BOLT ON TRACTION BAR KIT 68" (LONG BED)	27, 56, 58	9.5"	2WD / 4WD
19963	1999-2010	WELD ON TRACTION BAR KIT 68" (SHORT BED)	18	9.5"	2WD / 4WD
19968	1999-2010	WELD ON TRACTION BAR KIT 68" (LONG BED)	18	9.5"	2WD / 4WD
85250	1999-2010	REAR AIR BAG KIT (USE W/ FTS 10" REAR SPRINGS)	27, 56	9.5"	2WD / 4WD
C10HD	1999-2010	10" REAR LEAF SPRINGS	55	9.5"	2WD / 4WD
CVDL40	1999-2010	CV FRONT DRIVE SHAFT 40"	35, 47	9.5"	4WD
85999	1999-2010	DIFFERENTIAL EAR REPLACEMENT BRACKET	27, 44, 59	9.5"	4WD

12" 2000 - 2010 CHEVY / GMC 1500HD / 2500HD / 3500HD

Complete drop down kit and 100% bolt on
 Front differential is dropped a full 12" to maintain proper CV axle angles
 Impact struts to distribute front suspension impact loads through frame
 Utilizes the factory front bump stops for superior ride quality
 Semi Gloss black powder-coat for a long lasting great look
 Basic kit includes Front and Rear steel braided brake lines
 No cutting on front differential or factory bump stops
 Cross-member are constructed of 1/4" thick steel
 Lifetime Warranty against manufactures defects
 4WD kits include Front Drive Shaft
 No exhaust modification required
 No wheel restrictions
 Max Recommended Tire Size 40"
 Max Recommended Wheel Width 12"



2WD SILVERADO / SIERRA 1500HD
2500HD / 3500HD BASIC KIT Part # 85301

4WD SILVERADO / SIERRA 1500HD
2500HD / 3500HD BASIC KIT Part # 85306

Basic 2WD kit includes:

- 12" Front Box Kit
- 12" Rear Springs
- Front / Rear Steel Braided Brake Lines
- Rear DriveShaft Spacer

Basic 4WD kit includes:

- 12" Front Box Kit
- 12" Rear Springs
- Cv Front Drive Shaft
- Front / Rear Steel Braided Brake Lines
- Rear DriveShaft Spacer

Shocks Sold Separately.
Please see options below



PART #	YEAR	TITLE	FOOTNOTES	LIFT SIZE	2WD / 4WD
12" 2001-2010 CHEVY / GMC SILVERADO / SIERRA 1500HD / 2500HD / 3500HD					
85301	2001-2006	SILVERADO / SIERRA 1500HD / 2500HD / 3500HD BASIC KIT (W/ SINGLE REAR BRAKE LINE)	46, 52	12"	2WD
85305	2007-2008	SILVERADO / SIERRA 1500HD / 2500HD / 3500HD BASIC KIT (W/ SINGLE REAR BRAKE LINE)	46, 52	12"	2WD
85307	2008-2010	SILVERADO / SIERRA 1500HD / 2500HD / 3500HD BASIC KIT (W/ DUAL REAR BRAKE LINE)	46, 52	12"	2WD
85302	1999-2006	SILVERADO / SIERRA 1500HD / 2500HD / 3500HD BASIC KIT (W/ SINGLE REAR BRAKE LINE)	45, 52	12"	4WD
85304	2007-2008	SILVERADO / SIERRA 1500HD / 2500HD / 3500HD BASIC KIT (W/ SINGLE REAR BRAKE LINE)	45, 52	12"	4WD
85306	2008-2010	SILVERADO / SIERRA 1500HD / 2500HD / 3500HD BASIC KIT (W/ DUAL REAR BRAKE LINE)	45, 52	12"	4WD
12" 1999-2000 CHEVY / GMC SILVERADO / SIERRA 2500					
85309	1999-2000	SILVERADO / SIERRA 2500 NON HD BASIC KIT (W/ SINGLE REAR BRAKE LINE)	45, 52	12"	4WD
DOUBLE FRONT SHOCK UPGRADE					
85238	1999-2010	DOUBLE FRONT HOOPS W/ UNI BALL UPPER A ARMS	27, 40, 41	12"	2WD / 4WD
85239	1999-2010	DOUBLE FRONT HOOPS W/ BALL JOINT UPPER A ARMS	27, 41	12"	2WD / 4WD
85240	1999-2010	DOUBLE FRONT HOOPS W/ UPPER A ARMS BRACKETS	27	12"	2WD / 4WD
85242	1999-2010	UNI BALL UPPER A ARMS	40, 41	12"	2WD / 4WD
85241	1999-2010	BALL JOINT UPPER A ARMS	41	12"	2WD / 4WD
C2011-625R	1999-2010	FTS 2.0 REMOTE RESERVOIR 11" TRAVEL CHROME FINISH (DOUBLE FRONT SHOCK)	29, 30	12"	2WD / 4WD
B2011-625R	1999-2010	FTS 2.0 REMOTE RESERVOIR 11" TRAVEL BLACK FINISH (DOUBLE FRONT SHOCK)	29, 31	12"	2WD / 4WD
SINGLE FRONT SHOCK STOCK LOCATION					
C2012-625RS	1999-2010	FTS 2.0 REMOTE RESERVOIR 12" TRAVEL CHROME FINISH (STOCK FRONT LOCATION)	29, 30	12"	2WD / 4WD
B2012-625RS	1999-2010	FTS 2.0 REMOTE RESERVOIR 12" TRAVEL BLACK FINISH (STOCK FRONT LOCATION)	29, 31	12"	2WD / 4WD
SINGLE REAR SHOCK STOCK LOCATION					
C2014-625R	1999-2010	FTS 2.0 REMOTE RESERVOIR 14" TRAVEL CHROME FINISH (STOCK REAR LOCATION)	29, 30	12"	2WD / 4WD
B2014-625R	1999-2010	FTS 2.0 REMOTE RESERVOIR 14" TRAVEL BLACK FINISH (STOCK REAR LOCATION)	29, 31	12"	2WD / 4WD
DOUBLE REAR SHOCK BRACKET					
85249	1999-2010	DOUBLE REAR SHOCK BRACKET KIT *REQUIRES 11" TRAVEL SHOCK	12, 18, 27	12"	2WD / 4WD
C2011-625R	1999-2010	FTS 2.0 REMOTE RESERVOIR 11" TRAVEL CHROME FINISH (DOUBLE REAR SHOCK)	29, 30	12"	2WD / 4WD
B2011-625R	1999-2010	FTS 2.0 REMOTE RESERVOIR 11" TRAVEL BLACK FINISH (DOUBLE REAR SHOCK)	29, 31	12"	2WD / 4WD
BILLET SHOCK CLAMPS					
C2020	1999-2010	FTS 2.0 TO 2.0 BILLET SHOCK CLAMPS CHROME FINISH	38	12"	2WD / 4WD
B2020	1999-2010	FTS 2.0 TO 2.0 BILLET SHOCK CLAMPS BLACK FINISH	38	12"	2WD / 4WD
ACCESSORIES					
85222	1999-2006	FRONT / REAR STEEL BRAIDED BRAKE LINE KIT (SINGLE REAR)	79	12"	2WD / 4WD
85226	2007-2008	FRONT / REAR STEEL BRAIDED BRAKE LINE KIT (SINGLE REAR)	79	12"	2WD / 4WD
85227	2008-2010	FRONT / REAR STEEL BRAIDED BRAKE LINE KIT (DUAL REAR)	79	12"	2WD / 4WD
85243	1999-2010	HEAVY DUTY HEIMS JOINT STEERING KIT	19, 22, 23	12"	2WD / 4WD
85246	1999-2010	DOUBLE FRONT STEERING STABILIZER KIT W/ BASIC HYDRAULIC STABILIZERS	56	12"	2WD / 4WD
85147	1999-2010	DOUBLE FRONT STEERING STABILIZER KIT W/ FTS 2.0 CHROME STABILIZERS	56	12"	2WD / 4WD
85148	1999-2010	DOUBLE FRONT STEERING STABILIZER KIT W/ FTS 2.0 BLACK STABILIZERS	56	12"	2WD / 4WD
85251	1999-2010	IDLER ARM BRACE HD	18	12"	2WD / 4WD
14963	1999-2010	BOLT ON TRACTION BAR KIT 63" (SHORT BED)	27, 56, 58	12"	2WD / 4WD
14978	1999-2010	BOLT ON TRACTION BAR KIT 78" (LONG BED)	27, 56, 58	12"	2WD / 4WD
19963	1999-2010	WELD ON TRACTION BAR KIT 63" (SHORT BED)	18	12"	2WD / 4WD
19978	1999-2010	WELD ON TRACTION BAR KIT 78" (LONG BED)	18	12"	2WD / 4WD
85350	1999-2010	REAR AIR BAG KIT (USE W/ FTS 12" REAR SPRINGS)	27, 56	12"	2WD / 4WD
HD12	1999-2010	12" REAR LEAF SPRINGS	55	12"	2WD / 4WD
CVDL40	1999-2010	CV FRONT DRIVE SHAFT 40"	35, 47	12"	4WD
1410	2000-2006	1410 SERIES REAR DRIVE SHAFT SPACER	60	12"	2WD/4WD
1480	2007-2010	1480 SERIES REAR DRIVE SHAFT SPACER	60	12"	2WD/4WD
85999	1999-2010	DIFFERENTIAL EAR REPLACEMENT BRACKET	27, 44, 59	12"	4WD

Part# 85238



Part# 85227



Part# 85999

Part# 85243



Part# 1480

Part# 85426



Part# 85147

Basic Shocks

Front Shock Stock Location	129510
Rear Shock Stock Location	336000
Double Front Shock	129500
Double Rear Shock	129500

16" 2000 - 2010 CHEVY / GMC 1500HD / 2500HD / 3500HD

16" CHEVY / GMC 2000-2010 1500HD / 2500HD / 3500HD TRUCK

Complete drop down kit and 100% bolt on
 Front differential is dropped a full 16" to maintain proper CV axle angles
 Impact struts to distribute front suspension impact loads through frame
 Utilizes the factory front bump stops for superior ride quality
 Semi Gloss black powder-coat for a long lasting great look
 Basic kit includes Front and Rear steel braided brake lines
 No cutting on front differential or factory bump stops
 Cross-member are constructed of 1/4" thick steel
 Lifetime Warranty against manufactures defects

Max Recommended Tire Size 42" Max Recommended Wheel Width 12"
 4WD SILVERADO / SIERRA 1500HD
 2500HD / 3500HD BASIC KIT Part # 85406

2WD SILVERADO / SIERRA 1500HD
 2500HD / 3500HD BASIC KIT Part # 85401



Basic 2WD Kit includes:
 16" Front Box Kit
 12" Rear Springs & 4" Block Kit
 Front / Rear Steel Braided Brake Lines
 Rear Drive Shaft Spacer

Basic 4WD Kit includes:
 16" Front Box Kit
 12" Rear Springs & 4" Block Kit
 Front / Rear Steel Braided Brake Lines
 Rear Drive Shaft Spacer
 Front Drive Shaft

Shocks Sold Separately
 Please see options below



PART #	YEAR	TITLE	FOOTNOTES	LIFT SIZE	2WD / 4WD
16" 2000-2010 CHEVY / GMC SILVERADO / SIERRA 1500HD / 2500HD / 3500HD					
85401	2001-2006	SILVERADO / SIERRA 1500HD / 2500HD / 3500HD (W/ SINGLE REAR BRAKE LINE)	21, 52	16"	2WD
85405	2007-2008	SILVERADO / SIERRA 1500HD / 2500HD / 3500HD (W/ SINGLE REAR BRAKE LINE)	21, 52	16"	2WD
85407	2008-2010	SILVERADO / SIERRA 1500HD / 2500HD / 3500HD (W/ DUAL REAR BRAKE LINE)	21, 52	16"	2WD
85402	2001-2006	SILVERADO / SIERRA 1500HD / 2500HD / 3500HD (W/ SINGLE REAR BRAKE LINE)	20, 52	16"	4WD
85404	2007-2008	SILVERADO / SIERRA 1500HD / 2500HD / 3500HD (W/ SINGLE REAR BRAKE LINE)	20, 52	16"	4WD
85406	2008-2010	SILVERADO / SIERRA 1500HD / 2500HD / 3500HD (W/ DUAL REAR BRAKE LINE)	20, 52	16"	4WD
16" 1999-2000 CHEVY / GMC SILVERADO / SIERRA 2500					
85409	1999-2000	SILVERADO / SIERRA 2500 NON HD BASIC KIT (W/ SINGLE REAR BRAKE LINE)	20, 52	16"	4WD
DOUBLE FRONT SHOCK UPGRADE					
85238	1999-2010	DOUBLE FRONT HOOPS W/ UNI BALL UPPER A ARMS	27, 40, 41	16"	2WD / 4WD
85239	1999-2010	DOUBLE FRONT HOOPS W/ BALL JOINT UPPER A ARMS	27, 41	16"	2WD / 4WD
85240	1999-2010	DOUBLE FRONT HOOPS W/ UPPER A ARMS BRACKETS	27	16"	2WD / 4WD
85242	1999-2010	UNI BALL UPPER A ARMS	40, 41	16"	2WD / 4WD
85241	1999-2010	BALL JOINT UPPER A ARMS	41	16"	2WD / 4WD
C2012-625R	1999-2010	FTS 2.0 REMOTE RESERVOIR 12" TRAVEL CHROME FINISH (DOUBLE FRONT SHOCK)	29, 30	16"	2WD / 4WD
B2012-625R	1999-2010	FTS 2.0 REMOTE RESERVOIR 12" TRAVEL BLACK FINISH (DOUBLE FRONT SHOCK)	29, 31	16"	2WD / 4WD
SINGLE FRONT SHOCK STOCK LOCATION					
C2014-625RS	1999-2010	FTS 2.0 REMOTE RESERVOIR 14" TRAVEL CHROME FINISH (STOCK FRONT LOCATION)	29, 30	16"	2WD / 4WD
B2014-625RS	1999-2010	FTS 2.0 REMOTE RESERVOIR 14" TRAVEL BLACK FINISH (STOCK FRONT LOCATION)	29, 31	16"	2WD / 4WD
SINGLE REAR SHOCK STOCK LOCATION					
C2016-875R	1999-2010	FTS 2.0 REMOTE RESERVOIR 16" TRAVEL CHROME FINISH (STOCK REAR LOCATION)	29, 30	16"	2WD / 4WD
B2016-875R	1999-2010	FTS 2.0 REMOTE RESERVOIR 16" TRAVEL BLACK FINISH (STOCK REAR LOCATION)	29, 31	16"	2WD / 4WD
DOUBLE REAR SHOCK BRACKET					
85249	1999-2010	DOUBLE REAR SHOCK BRACKET KIT *REQUIRES 12" TRAVEL SHOCK	12, 18, 27	16"	2WD / 4WD
C2012-625R	1999-2010	FTS 2.0 REMOTE RESERVOIR 12" TRAVEL CHROME FINISH (DOUBLE REAR SHOCK)	29, 30	16"	2WD / 4WD
B2012-625R	1999-2010	FTS 2.0 REMOTE RESERVOIR 12" TRAVEL BLACK FINISH (DOUBLE REAR SHOCK)	29, 31	16"	2WD / 4WD
BILLET SHOCK CLAMPS					
C2020	1999-2010	FTS 2.0 TO 2.0 BILLET SHOCK CLAMPS CHROME FINISH	38	16"	2WD / 4WD
B2020	1999-2010	FTS 2.0 TO 2.0 BILLET SHOCK CLAMPS BLACK FINISH	38	16"	2WD / 4WD
ACCESSORIES					
85222-16	1999-2006	FRONT / REAR STEEL BRAIDED BRAKE LINE KIT (SINGLE REAR)	79	16"	2WD / 4WD
85226-16	2007-2008	FRONT / REAR STEEL BRAIDED BRAKE LINE KIT (SINGLE REAR)	79	16"	2WD / 4WD
85227-16	2008-2010	FRONT / REAR STEEL BRAIDED BRAKE LINE KIT (DUAL REAR)	79	16"	2WD / 4WD
85243	1999-2010	HEAVY DUTY HEIMS JOINT STEERING KIT	19, 22, 23	16"	2WD / 4WD
85246	1999-2010	DOUBLE FRONT STEERING STABILIZER KIT W/ BASIC HYDRAULIC STABILIZERS	56	16"	2WD / 4WD
85147	1999-2010	DOUBLE FRONT STEERING STABILIZER KIT W/ FTS 2.0 CHROME STABILIZERS	56	16"	2WD / 4WD
85148	1999-2010	DOUBLE FRONT STEERING STABILIZER KIT W/ FTS 2.0 BLACK STABILIZERS	56	16"	2WD / 4WD
85251	1999-2010	IDLER ARM BRACE HD	18	16"	2WD / 4WD
14968	1999-2010	BOLT ON TRACTION BAR KIT 68" (SHORT BED)	27, 56, 58	16"	2WD / 4WD
14978	1999-2010	BOLT ON TRACTION BAR KIT 78" (LONG BED)	27, 56, 58	16"	2WD / 4WD
19968	1999-2010	WELD ON TRACTION BAR KIT 68" (SHORT BED)	18	16"	2WD / 4WD
19978	1999-2010	WELD ON TRACTION BAR KIT 78" (LONG BED)	18	16"	2WD / 4WD
85350	1999-2010	REAR AIR BAG KIT (USE W/ FTS 12" REAR SPRINGS)	27, 56	16"	2WD / 4WD
HD12	1999-2010	12" REAR LEAF SPRINGS	55	16"	2WD / 4WD
HD16	1999-2010	16" REAR LEAF SPRINGS	55	16"	2WD / 4WD
TW40	1999-2010	FRONT DRIVE SHAFT 40"	35, 47	16"	4WD
CBK25-400T	1999-2010	4" TAPERED BLOCK W/9/16" X 2.5" SQ X 14" SQUARE U BOLTS	22, 25	16"	2WD / 4WD
1410	2001-2006	1410 SERIES REAR DRIVE SHAFT SPACER	59, 60	16"	2WD/4WD
1480	2007-2010	1480 SERIES REAR DRIVE SHAFT SPACER	59, 60	16"	2WD/4WD
85999	1999-2010	DIFFERENTIAL EAR REPLACEMENT BRACKET	27, 44, 59	16"	4WD

9.5" 2000-10 GM 2500 SUBURBAN / AVALANCHE / YUKON XL

Complete drop down kit and 100% bolt on
 Front differential is dropped a full 9.5" to maintain proper CV axle angles
 Impact struts to distribute front suspension impact loads through frame
 No rear add a leaf makes for easy installation and factory ride quality
 Utilizes the factory front bump stops for superior ride quality
 Semi Gloss black powder-coat for a long lasting great look
 Basic kit includes Front and Rear steel braided brake lines
 No cutting on front differential or factory bump stops
 Cross-member are constructed of 1/4" thick steel
 Lifetime Warranty against manufactures defects
 No exhaust modification required

Max Recommended Tire Size 38"
 Max Recommended Wheel Width 12"



4WD SUBURBAN / AVALANCHE / YUKON XL BASIC KIT
 Part # 85213

2WD SUBURBAN / AVALANCHE / YUKON XL BASIC KIT
 Part # 85219

- Basic 2WD kit includes:**
 9.5" Front Box Kit
 10" Rear Springs
 Front / Rear Steel Braided Brake Lines
- Basic 4WD kit includes:**
 9.5" Front Box Kit
 10" Rear Springs
 CV Front Drive Shaft
 Front / Rear Steel Braided Brake Lines
- Shocks Sold Separately**
 Please see options below



PART #	YEAR	TITLE	FOOTNOTES	LIFT SIZE	2WD / 4WD
9.5" 2000-2010 CHEVY / GMC SUBURBAN / AVALANCHE / YUKON XL 2500					
85213	2000-2006	SUBURBAN / AVALANCHE / YUKON XL (W/ SINGLE REAR BRAKE LINE)	2, 52	9.5"	2WD
85215	2007-2008	SUBURBAN / AVALANCHE / YUKON XL (W/ SINGLE REAR BRAKE LINE)	2, 52	9.5"	2WD
85216	2008-2010	SUBURBAN / AVALANCHE / YUKON XL (W/ DUAL REAR BRAKE LINE)	2, 52	9.5"	2WD
85217	2000-2006	SUBURBAN / AVALANCHE / YUKON XL (W/ SINGLE REAR BRAKE LINE)	1, 52	9.5"	4WD
85218	2007-2008	SUBURBAN / AVALANCHE / YUKON XL (W/ SINGLE REAR BRAKE LINE)	1, 52	9.5"	4WD
85219	2008-2010	SUBURBAN / AVALANCHE / YUKON XL (W/ DUAL REAR BRAKE LINE)	1, 52	9.5"	4WD
DOUBLE FRONT SHOCK UPGRADE					
85238	2000-2010	DOUBLE FRONT HOOPS W/ UNI BALL UPPER A ARMS	27, 40, 41	9.5"	2WD / 4WD
85239	2000-2010	DOUBLE FRONT HOOPS W/ BALL JOINT UPPER A ARMS	27, 41	9.5"	2WD / 4WD
85240	2000-2010	DOUBLE FRONT HOOPS W/ UPPER A ARMS BRACKETS	27	9.5"	2WD / 4WD
85242	2000-2010	UNI BALL UPPER A ARMS	40, 41	9.5"	2WD / 4WD
85241	2000-2010	BALL JOINT UPPER A ARMS	41	9.5"	2WD / 4WD
C2010-625R	2000-2010	FTS 2.0 REMOTE RESERVOIR 10" TRAVEL CHROME FINISH (DOUBLE SHOCK)	29, 30	9.5"	2WD / 4WD
B2010-625R	2000-2010	FTS 2.0 REMOTE RESERVOIR 10" TRAVEL BLACK FINISH (DOUBLE SHOCK)	29, 31	9.5"	2WD / 4WD
SINGLE FRONT SHOCK STOCK LOCATION					
C2011-625RS	2000-2010	FTS 2.0 REMOTE RESERVOIR 11" TRAVEL CHROME FINISH (STOCK FRONT LOCATION)	29, 30	9.5"	2WD / 4WD
B2011-625RS	2000-2010	FTS 2.0 REMOTE RESERVOIR 11" TRAVEL BLACK FINISH (STOCK FRONT LOCATION)	29, 31	9.5"	2WD / 4WD
SINGLE REAR SHOCK STOCK LOCATION					
C2014-625R	2000-2010	FTS 2.0 REMOTE RESERVOIR 14" TRAVEL CHROME FINISH (STOCK REAR LOCATION)	29, 30	9.5"	2WD / 4WD
B2014-625R	2000-2010	FTS 2.0 REMOTE RESERVOIR 14" TRAVEL BLACK FINISH (STOCK REAR LOCATION)	29, 31	9.5"	2WD / 4WD
BILLET SHOCK CLAMPS					
C2020	2000-2010	FTS 2.0 TO 2.0 BILLET SHOCK CLAMPS CHROME FINISH	38	9.5"	2WD / 4WD
B2020	2000-2010	FTS 2.0 TO 2.0 BILLET SHOCK CLAMPS BLACK FINISH	38	9.5"	2WD / 4WD
ACCESSORIES					
85222	2000-2010	FRONT / REAR STEEL BRAIDED BRAKE LINE KIT (SINGLE REAR)	79	9.5"	2WD / 4WD
85226	2007-2008	FRONT / REAR STEEL BRAIDED BRAKE LINE KIT (SINGLE REAR)	79	9.5"	2WD / 4WD
85227	2008-2010	FRONT / REAR STEEL BRAIDED BRAKE LINE KIT (DUAL REAR)	79	9.5"	2WD / 4WD
85243	2000-2010	HEAVY DUTY HEIMS JOINT STEERING KIT	19, 22, 23	9.5"	2WD / 4WD
85246	2000-2010	DOUBLE FRONT STEERING STABILIZER KIT W/ BASIC HYDRAULIC STABILIZERS	56	9.5"	2WD / 4WD
85251	2000-2010	IDLER ARM BRACE HD	18	9.5"	2WD / 4WD
14963	2000-2010	BOLT ON TRACTION BAR KIT 63"	27, 56, 58	9.5"	2WD / 4WD
19963	2000-2010	WELD ON TRACTION BAR KIT 63"	18	9.5"	2WD / 4WD
85250	2000-2010	REAR AIR BAG KIT (USE W/ FTS 10" REAR SPRINGS)	56	9.5"	2WD / 4WD
SA10	2000-2010	10" REAR LEAF SPRINGS	55	9.5"	2WD / 4WD
CVDL40	2000-2010	CV FRONT DRIVE SHAFT 40"	35, 47	9.5"	4WD
85999	2000-2010	DIFFERENTIAL EAR REPLACEMENT BRACKET	27, 44, 59	9.5"	4WD



BASIC SHOCKS

Front Shock Stock Location	129510
Rear Shock Stock Location	132000000
Double Front Shock	126500
Double Rear Shock	126500

12" 2000-10 GM 2500 SUBURBAN / AVALANCHE / YUKON XL

Complete drop down kit and 100% bolt on
 Front differential is dropped a full 12" to maintain proper CV axle angles
 Impact struts to distribute front suspension impact loads through frame
 No rear add a leaf makes for easy installation and factory ride quality
 Utilizes the factory front bump stops for superior ride quality
 Semi Gloss black powder-coat for a long lasting great look
 Basic kit includes Front and Rear steel braided brake lines
 No cutting on front differential or factory bump stops
 Cross-members are constructed of 1/4" thick steel
 Lifetime Warranty against manufactures defects
 No exhaust modification required

Max Recommended Tire Size 40"
 Max Recommended Wheel Width 12"

SUBURBAN / AVALANCHE / YUKON XL BASIC KIT
 Part # 85315

SUBURBAN / AVALANCHE / YUKON XL BASIC KIT
 Part # 85332



2000-2010
 CHEVY / GMC
 1500HD / 2500HD / 3500HD TRUCK



Basic 2WD kit includes:
 12" Front Box Kit
 12" Rear Springs
 Front / Rear Steel Braided Brake Lines
 Rear Drive Shaft Spacer

Basic 4WD kit includes:
 12" Front Box Kit
 12" Rear Springs
 CV Front Drive Shaft
 Front / Rear Steel Braided Brake Lines
 Rear Drive Shaft Spacer

Shocks Sold Separately.
 Please see options below



PART #	YEAR	TITLE	FOOTNOTES	LIFT SIZE	2WD / 4WD
12" 2000-2010 CHEVY / GMC SUBURBAN / AVALANCHE / YUKON XL 2500HD					
85315	2000-2006	SUBURBAN / AVALANCHE / YUKON XL	46, 52	12"	2WD
85317	2007-2008	SUBURBAN / AVALANCHE / YUKON XL	46, 52	12"	2WD
85318	2009-2010	SUBURBAN / AVALANCHE / YUKON XL	46, 52	12"	2WD
85330	2000-2006	SUBURBAN / AVALANCHE / YUKON XL	45, 52	12"	4WD
85331	2007-2008	SUBURBAN / AVALANCHE / YUKON XL	45, 52	12"	4wd
85332	2009-2010	SUBURBAN / AVALANCHE / YUKON XL	45, 52	12"	4wd
DOUBLE FRONT SHOCK UPGRADE					
85238	2000-2010	DOUBLE FRONT HOOPS W/ UNI BALL UPPER A ARMS	27, 40, 41	12"	2WD / 4WD
85239	2000-2010	DOUBLE FRONT HOOPS W/ BALL JOINT UPPER A ARMS	27, 41	12"	2WD / 4WD
85240	2000-2010	DOUBLE FRONT HOOPS W/ UPPER A ARMS BRACKETS	27	12"	2WD / 4WD
85242	2000-2010	UNI BALL UPPER A ARMS	40, 41	12"	2WD / 4WD
85241	2000-2010	BALL JOINT UPPER A ARMS	41	12"	2WD / 4WD
C2011-625R	2000-2010	FTS 2.0 REMOTE RESERVOIR 11" TRAVEL CHROME FINISH (DOUBLE SHOCK)	29, 30	12"	2WD / 4WD
B2011-625R	2000-2010	FTS 2.0 REMOTE RESERVOIR 11" TRAVEL BLACK FINISH (DOUBLE SHOCK)	29, 31	12"	2WD / 4WD
SINGLE FRONT SHOCK STOCK LOCATION					
C2012-625RS	2000-2010	FTS 2.0 REMOTE RESERVOIR 12" TRAVEL CHROME FINISH (STOCK FRONT LOCATION)	29, 30	12"	2WD / 4WD
B2012-625RS	2000-2010	FTS 2.0 REMOTE RESERVOIR 12" TRAVEL BLACK FINISH (STOCK FRONT LOCATION)	29, 31	12"	2WD / 4WD
SINGLE REAR SHOCK STOCK LOCATION					
C2014-625R	2000-2010	FTS 2.0 REMOTE RESERVOIR 14" TRAVEL CHROME FINISH (STOCK REAR LOCATION)	29, 30	12"	2WD / 4WD
B2014-625R	2000-2010	FTS 2.0 REMOTE RESERVOIR 14" TRAVEL BLACK FINISH (STOCK REAR LOCATION)	29, 31	12"	2WD / 4WD
BILLET SHOCK CLAMPS					
C2020	2000-2010	FTS 2.0 TO 2.0 BILLET SHOCK CLAMPS CHROME FINISH	38	12"	2WD / 4WD
B2020	2000-2010	FTS 2.0 TO 2.0 BILLET SHOCK CLAMPS BLACK FINISH	38	12"	2WD / 4WD
ACCESSORIES					
85222	2000-2010	FRONT / REAR STEEL BRAIDED BRAKE LINE KIT (SINGLE REAR)	79	12"	2WD / 4WD
85226	2000-2010	FRONT / REAR STEEL BRAIDED BRAKE LINE KIT (SINGLE REAR)	79	12"	2WD / 4WD
85227	2000-2010	FRONT / REAR STEEL BRAIDED BRAKE LINE KIT (DUAL REAR)	79	12"	2WD / 4WD
85243	2000-2010	HEAVY DUTY HEIMS JOINT STEERING KIT	19, 22, 23	12"	2WD / 4WD
85246	2000-2010	DOUBLE FRONT STEERING STABILIZER KIT W/ BASIC HYDRAULIC STABILIZERS	56	12"	2WD / 4WD
85251	2000-2010	IDLER ARM BRACE HD	18	12"	2WD / 4WD
14963	2000-2010	BOLT ON TRACTION BAR KIT 63"	27, 56, 58	12"	2WD / 4WD
19963	2000-2010	WELD ON TRACTION BAR KIT 63"	18	12"	2WD / 4WD
85350	2000-2010	REAR AIR BAG KIT (USE W/ FTS 12" SPRINGS)	27, 56	12"	2WD / 4WD
SA12	2000-2010	12" REAR LEAF SPRINGS	55	12"	2WD / 4WD
CVDL40	2000-2010	CV FRONT DRIVE SHAFT 40"	35, 47	12"	4WD
1350	2000-2010	1350 SERIES REAR DRIVE SHAFT SPACER	59, 60	12"	2WD/4WD
1410	2000-2010	1410 SERIES REAR DRIVE SHAFT SPACER	59, 60	12"	2WD/4WD
85999	2000-2010	DIFFERENTIAL EAR REPLACEMENT BRACKET	27, 44, 59	12"	4WD

Basic Shocks

Front Shock Stock Location	129510
Rear Shock Stock Location	336000
Double Front Shock	129500
Double Rear Shock	129500

See website for more details

2011-2013
CHEVY / GMC
2500HD / 3500HD TRUCK

4"
INCH

4" 2011 - 2013 CHEVY / GMC 2500HD / 3500HD

100% Bolt On - Spindle kit that DOES NOT extended the track width
Utilizes ductile iron steering knuckle for stock alignment;
Superior driveability both on and offroad
Structural crossmembers constructed of 1/4" thick steel for superior strength
Option to use your kit with or without torsion bar drops
All 4 factory bump stops incorporated for durability
Front differential dropped full 4" for flat C/V angles
Differential skid plate keeps your diff away from debris
Heavy duty semi gloss black powder for long life and great looks
Impact struts to distribute suspension impact throughout the frame
Less cutting of factory frame and differential than other kits

Max Recommended Tire Size 35"
Max Recommended Wheel Width 9"



Basic 2WD kit includes:
4" Front Box Kit
LH / RH Steering Knuckles
3" Rear Block Kit

Basic 4WD kit includes:
4" Front Box Kit
LH / RH Steering Knuckles
3" Rear Block Kit

Shocks Sold Separately Please see options below

2WD SILVERADO / SIERRA 2500HD / 3500HD
(W/ TORRSION BAR DROP)
Part # 44106

4WD SILVERADO / SIERRA 2500HD / 3500HD
(W/ TORRSION BAR DROP)
Part # 44104

4WD SILVERADO / SIERRA 2500HD / 3500HD
(NON TORRSION BAR DROP)
Part # 44108



PART #	YEAR	TITLE	FOOTNOTES	LIFT SIZE	2WD / 4WD
4" 2011-2013 CHEVY / GMC SILVERADO / SIERRA 2500HD / 3500HD					
44102	2011-2013	SILVERADO / SIERRA 2500HD/3500HD (NON TORRSION BAR DROP)	4, 19, 52	4"	2WD
44106	2011-2013	SILVERADO / SIERRA 2500HD/3500HD (W/ TORRSION BAR DROP)	4, 19, 52	4"	2WD
44108	2011-2013	SILVERADO / SIERRA 2500HD/3500HD (NON TORRSION BAR DROP)	4, 19, 52	4"	4WD
44104	2011-2013	SILVERADO / SIERRA 2500HD/3500HD (W/ TORRSION BAR DROP)	4, 19, 52	4"	4WD
STOCK SHOCK BRACKET EXTENDER KIT (FOR USE WITH STOCK SHOCK)					
44120	2011-2013	FRONT / REAR SHOCK BRACKETS TO UTILIZE FACTORY SHOCKS	27, 56	4"	2WD/4WD
DOUBLE FRONT SHOCK UPGRADE					
48139	2011-2013	DOUBLE FRONT HOOPS W/ BALL JOINT UPPER A ARMS	27, 41	4"	2WD/4WD
49841	2011-2013	BALL JOINT UPPER A ARMS	41	4"	2WD/4WD
C2045-625R	2011-2013	FTS 2.0 REMOTE RESERVOIR 4.5" TRAVEL CHROME FINISH (DOUBLE FRONT SHOCK)	29, 30	4"	2WD/4WD
B2045-625R	2011-2013	FTS 2.0 REMOTE RESERVOIR 4.5" TRAVEL BLACK FINISH (DOUBLE FRONT SHOCKS)	29, 31	4"	2WD/4WD
SINGLE FRONT SHOCK STOCK LOCATION					
C2085-625RUU	2011-2013	FTS 2.0 REMOTE RESERVOIR 8.5" TRAVEL CHROME FINISH (STOCK FRONT LOCATION)	29, 30	4"	2WD/4WD
B2085-625RUU	2011-2013	FTS 2.0 REMOTE RESERVOIR 8.5" TRAVEL BLACK FINISH (STOCK FRONT LOCATION)	29, 31	4"	2WD/4WD
SINGLE REAR SHOCK STOCK LOCATION					
C2011-625R	2011-2013	FTS 2.0 REMOTE RESERVOIR 11" TRAVEL CHROME FINISH (STOCK REAR LOCATION)	29, 30	4"	2WD/4WD
B2011-625R	2011-2013	FTS 2.0 REMOTE RESERVOIR 11" TRAVEL BLACK FINISH (STOCK REAR LOCATION)	29, 31	4"	2WD / 4WD
PREMIUM DOUBLE REAR SHOCK BRACKET W/ UPPER CROSSMEMBER					
48159	2011-2013	DOUBLE REAR SHOCK CROSSMEMBER KIT	12, 18, 27	4"	2WD/4WD
C2011-625R	2011-2013	FTS 2.0 REMOTE RESERVOIR 11" TRAVEL CHROME FINISH (DOUBLE REAR SHOCK)	29, 30	4"	2WD/4WD
B2011-625R	2011-2013	FTS 2.0 REMOTE RESERVOIR 11" TRAVEL BLACK FINISH (DOUBLE REAR SHOCK)	29, 31	4"	2WD/4WD
ECONOMY DOUBLE REAR SHOCK BRACKET					
48151	2011-2013	DOUBLE REAR SHOCK BRACKET KIT	12, 18, 27	4"	2WD/4WD
C2085-625R	2011-2013	FTS 2.0 REMOTE RESERVOIR 8.5" TRAVEL CHROME FINISH (DOUBLE REAR SHOCK)	29, 30	4"	2WD/4WD
B2085-625R	2011-2013	FTS 2.0 REMOTE RESERVOIR 8.5" TRAVEL BLACK FINISH (DOUBLE RAR SHOCK)	29, 31	4"	2WD/4WD
BILLET SHOCK CLAMPS					
C2020	2011-2013	FTS 2.0 TO 2.0 BILLET SHOCK CLAMPS CHROME FINISH	38	4"	2WD/4WD
B2020	2011-2013	FTS 2.0 TO 2.0 BILLET SHOCK CLAMPS BLACK FINISH	38	4"	2WD/4WD
C2015	2011-2013	FTS 2.0 TO 1.5 BILLET SHOCK CLAMPS CHROME FINISH	38	4"	2WD/4WD
B2015	2011-2013	FTS 2.0 TO 1.5 BILLET SHOCK CLAMPS BLACK FINISH	38	4"	2WD/4WD
ACCESSORIES					
44132	2011-2013	FRONT / REAR STEEL BRAIDED BRAKE LINE KIT (DUAL REAR)	79	4"	2WD/4WD
44144	2011-2013	HEIMS JOINT STEERING W/ STEERING BAR	19, 22, 23	4"	2WD/4WD
44143	2011-2013	HEIMS JOINT STEERING CONVERSION KIT W/ U BRACKETS	19, 22, 23	4"	2WD/4WD
48246	2011-2013	DOUBLE FRONT STEERING STABILIZER KIT W/ BASIC HYDRAULIC STABILIZERS	56	4"	2WD/4WD
48247	2011-2013	DOUBLE FRONT STEERING STABILIZER KIT W/ FTS 2.0 CHROME STABILIZERS	30, 56	4"	2WD/4WD
48248	2011-2013	DOUBLE FRONT STEERING STABILIZER KIT W/ FTS 2.0 BLACK STABILIZERS	31, 56	4"	2WD/4WD
15963	2011-2013	BOLT ON TRACTION BAR KIT 63" (SHORT BED)	27, 56, 58	4"	2WD/4WD
15970	2011-2013	BOLT ON TRACTION BAR KIT 70" (LONG BED)	27, 56, 58	4"	2WD/4WD
44150	2011-2013	REAR AIR BAG KIT	27	4"	2WD/4WD
CBK30-216T	2011-2013	2.00" TAPERD BLOCK W/ 3/4" X 3.25 X 16" SQUARE U BOLTS	57	4"	2WD/4WD
CBK30-316T	2011-2013	3.00" TAPERD BLOCK W/ 3/4" X 3.25 X 16" SQUARE U BOLTS	57	4"	2WD/4WD
CBK30-418T	2011-2013	4.00" TAPERD BLOCK W/ 3/4" X 3.25 X 18" SQUARE U BOLTS	57	4"	2WD/4WD
48411	2011-2013	IDLER ARM BRACE	18	4"	2WD/4WD
486500	2011-2013	UREA TANK SKID PLATE (DIESEL EXHAUST FLUID TANK)	56	4"	2WD/4WD
38316	2011-2013	2.5" TORSION KEY KIT	52	4"	2WD/4WD

7" 2011 - 2013 CHEVY / GMC 2500HD / 3500HD

7" INCH
2500HD / 3500HD TRUCK
2011-2013
CHEVY / GMC

100% Bolt On 7" Spindle Kit
Structural crossmembers constructed of 1/4" thick steel for superior strength
Utilizes ductile iron steering knuckle for stock alignment
Superior driveability both on and offroad
Option to use your kit with or without torsion bar drops
Only increases track width by 1/2" per side
All 4 factory bump stops incorporated for durability
Front differential dropped full 7" for flat C/V angles
Front differential skid plate keeps your diff away from debris
Heavy duty semi gloss black powder for long life and great looks
Impact struts to distribute suspension impact throughout the frame
Less cutting of factory frame and differential than other kits
Rear lift block with integrated bump stop



Basic 2WD kit includes:
7" Front Box Kit
LH / RH Steering Knuckles
4" Rear Block Kit
Basic 4WD kit includes:
7" Front Box Kit
LH / RH Steering Knuckles
4" Rear Block Kit
Shocks Sold Separately,
Please see options below

Max Recommended Tire Size 35" Max Recommended Wheel Width 12"
Max Recommended Tire Size 37" Max Recommended Wheel Width 10"
Required 17" or larger Wheel with no more than 5" Backspace

2WD SILVERADO / SIERRA 2500HD / 3500HD
(W/ TORRSION BAR DROP) Part # 46106

4WD SILVERADO / SIERRA 2500HD / 3500HD
(W/ TORRSION BAR DROP) Part # 46108

4WD SILVERADO / SIERRA 2500HD / 3500HD
(NON TORRSION BAR DROP) Part # 46104



PART #	YEAR	TITLE	FOOTNOTES	LIFT SIZE	2WD / 4WD
7" 2011-2013 CHEVY / GMC SILVERADO / SIERRA 2500HD / 3500HD					
46102	2011-2013	SILVERADO / SIERRA 2500HD/3500HD (NON TORRSION BAR DROP)	4, 8, 19, 52	7"	2WD
46106	2011-2013	SILVERADO / SIERRA 2500HD/3500HD (W/ TORRSION BAR DROP)	4, 8, 19, 52	7"	2WD
46108	2011-2013	SILVERADO / SIERRA 2500HD/3500HD (NON TORRSION BAR DROP)	4, 8, 19, 52	7"	4WD
46104	2011-2013	SILVERADO / SIERRA 2500HD/3500HD (W/ TORRSION BAR DROP)	4, 8, 19, 52	7"	4WD
STOCK SHOCK BRACKET EXTENDER KIT (FOR USE WITH STOCK SHOCK)					
46120	2011-2013	FRONT / REAR SHOCK BRACKETS TO UTILIZE FACTORY SHOCKS	27, 56	7"	2WD/4WD
DOUBLE FRONT SHOCK UPGRADE					
48139	2011-2013	DOUBLE FRONT HOOPS W/ BALL JOINT UPPER A ARMS	27, 41	7"	2WD/4WD
49841	2011-2013	BALL JOINT UPPER A ARMS	41	7"	2WD/4WD
C2045-625R	2011-2013	FTS 2.0 REMOTE RESERVOIR 4.5" TRAVEL CHROME FINISH (DOUBLE FRONT SHOCK)	29, 30	7"	2WD/4WD
B2045-625R	2011-2013	FTS 2.0 REMOTE RESERVOIR 4.5" TRAVEL BLACK FINISH (DOUBLE FRONT SHOCKS)	29, 31	7"	2WD/4WD
SINGLE FRONT SHOCK STOCK LOCATION W/ TORRSION BAR DROP KIT					
C2090-625RUU	2011-2013	FTS 2.0 REMOTE RESERVOIR 9" TRAVEL CHROME FINISH (STOCK FRONT LOCATION)	29, 30	7"	2WD/4WD
B2090-625RUU	2011-2013	FTS 2.0 REMOTE RESERVOIR 9" TRAVEL BLACK FINISH (STOCK FRONT LOCATION)	29, 31	7"	2WD/4WD
SINGLE FRONT SHOCK STOCK LOCATION W/ NON TORRSION BAR DROP KIT					
C2090-625RU	2011-2013	FTS 2.0 REMOTE RESERVOIR 9.0" TRAVEL CHROME FINISH (STOCK FRONT LOCATION)	29, 30	7"	2WD/4WD
B2090-625RU	2011-2013	FTS 2.0 REMOTE RESERVOIR 9.0" TRAVEL BLACK FINISH (STOCK FRONT LOCATION)	29, 31	7"	2WD/4WD
SINGLE REAR SHOCK STOCK LOCATION					
C2011-625R	2011-2013	FTS 2.0 REMOTE RESERVOIR 11" TRAVEL CHROME FINISH (STOCK REAR LOCATION)	29, 30	7"	2WD/4WD
B2011-625R	2011-2013	FTS 2.0 REMOTE RESERVOIR 11" TRAVEL BLACK FINISH (STOCK REAR LOCATION)	29, 31	7"	2WD/4WD
PREMIUM DOUBLE REAR SHOCK BRACKET W/ UPPER CROSSMEMBER					
48159	2011-2013	DOUBLE REAR SHOCK CROSSMEMBER KIT	12,18, 27	7"	2WD/4WD
C2012-625R	2011-2013	FTS 2.0 REMOTE RESERVOIR 12" TRAVEL CHROME FINISH (DOUBLE REAR SHOCK)	29, 30	7"	2WD/4WD
B2012-625R	2011-2013	FTS 2.0 REMOTE RESERVOIR 12" TRAVEL BLACK FINISH (DOUBLE RAR SHOCK)	29, 31	7"	2WD/4WD
ECONOMY DOUBLE REAR SHOCK BRACKET					
48151	2011-2013	DOUBLE REAR SHOCK BRACKET KIT	12,18, 27	7"	2WD/4WD
C2010-625R	2011-2013	FTS 2.0 REMOTE RESERVOIR 10" TRAVEL CHROME FINISH (DOUBLE REAR SHOCK)	29, 30	7"	2WD/4WD
B2010-625R	2011-2013	FTS 2.0 REMOTE RESERVOIR 10" TRAVEL BLACK FINISH (DOUBLE RAR SHOCK)	29, 31	7"	2WD/4WD
BILLET SHOCK CLAMPS					
C2020	2011-2013	FTS 2.0 TO 2.0 BILLET SHOCK CLAMPS CHROME FINISH	38	7"	2WD/4WD
B2020	2011-2013	FTS 2.0 TO 2.0 BILLET SHOCK CLAMPS BLACK FINISH	38	7"	2WD/4WD
C2015	2011-2013	FTS 2.0 TO 1.5 BILLET SHOCK CLAMPS CHROME FINISH	38	7"	2WD/4WD
B2015	2011-2013	FTS 2.0 TO 1.5 BILLET SHOCK CLAMPS BLACK FINISH	38	7"	2WD/4WD
ACCESSORIES					
46132	2011-2013	FRONT / REAR STEEL BRAIDED BRAKE LINE KIT (DUAL REAR)	79	7"	2WD/4WD
46144	2011-2013	HEIMS JOINT STEERING W/ STEERING BAR	19, 22, 23	7"	2WD/4WD
46143	2011-2013	HEIMS JOINT STEERING CONVERSION KIT W/ U BRACKETS	19, 22, 23	7"	2WD/4WD
48246	2011-2013	DOUBLE FRONT STEERING STABILIZER KIT W/ BASIC HYDRAULIC STABILIZERS	56	7"	2WD/4WD
48247	2011-2013	DOUBLE FRONT STEERING STABILIZER KIT W/ FTS 2.0 CHROME STABILIZERS	30, 56	7"	2WD/4WD
48248	2011-2013	DOUBLE FRONT STEERING STABILIZER KIT W/ FTS 2.0 BLACK STABILIZERS	31, 56	7"	2WD/4WD
15963	2011-2013	BOLT ON TRACTION BAR KIT 63" (SHORT BED)	27, 56, 58	7"	2WD/4WD
15970	2011-2013	BOLT ON TRACTION BAR KIT 70" (LONG BED)	27, 56, 58	7"	2WD/4WD
46150	2011-2013	REAR AIR BAG KIT	27	7"	2WD/4WD
CBK30-318T	2011-2013	3.00" TAPERD BLOCK W/ 3/4" X 3.25 X 18" SQUARE U BOLTS	57	7"	2WD/4WD
CBK30-418T	2011-2013	4.00" TAPERD BLOCK W/ 3/4" X 3.25 X 18" SQUARE U BOLTS	57	7"	2WD/4WD
48411	2011-2013	IDLER ARM BRACE	18	7"	2WD/4WD
CVDL40	2011-2013	CV FRONT DRIVE SHAFT 40"	35, 47	7"	4WD
486500	2011-2013	UREA TANK SKID PLATE (DIESEL EXHAUST FLUID TANK)	56	7"	2WD/4WD
38316	2011-2013	2.5" TORSION KEY KIT	52	7"	2WD/4WD

Part# 48139



Part# C2045-625R Chrome
Also available in Black Finish



Part# 46132



Part# 46144



Part# 15963



10" INCH

2011-2013 CHEVY / GMC 2500HD / 3500HD TRUCK

10" 2011 - 2013 CHEVY / GMC 2500HD / 3500HD

- 100% Bolt On 10" Spindle Kit
- Utilizes ductile iron steering knuckle for stock alignment;
- Superior driveability both on and offroad
- Option to use your kit with or without torsion bar drops
- Only increases track width by 1" per side
- All 4 factory bump stops incorporated for durability
- Front differential dropped full 10" for flat C/V angles
- Differential skid plate keeps your diff away from debris
- Heavy duty semi gloss black powder for long life and great looks
- Impact struts to distribute suspension impact throughout the frame
- Structural crossmembers constructed of 1/4" thick steel for superior strength
- Rear lift block with integrated bump stop
- Max Recommended Tire Size 38" Max Recommended Wheel Width 12"
- Max Recommended Tire Size 39" Max Recommended Wheel Width 10"
- Required 17" or larger Wheel with no more than 5" Backspace



2WD SILVERADO / SIERRA 2500HD / 3500HD (W/ REAR BLOCKS) **Part# 48102**

4WD SILVERADO / SIERRA 2500HD / 3500HD (W/ REAR BLOCKS) **Part# 48105**



- Basic 2WD kit includes:**
- 10" Front Box Kit
 - 7" Rear Block Kit
 - LH / RH Steering Knuckles
 - Front / Rear Steel Braided Brake Lines
- Basic 4WD kit includes:**
- 10" Front Box Kit
 - 7" Rear Block Kit
 - LH / RH Steering Knuckles
 - Cv Front Drive Shaft
 - Front / Rear Steel Braided Brake Lines

Shocks Sold Separately. Please see options below.



PART #	YEAR	TITLE	FOOTNOTES	LIFT SIZE	2WD / 4WD
10" 2011-2013 CHEVY / GMC SILVERADO / SIERRA 2500HD / 3500HD					
48102	2011-2013	SILVERADO / SIERRA 2500HD / 3500HD	6, 9, 19, 52	10"	2WD
48104	2011-2013	SILVERADO / SIERRA 2500HD / 3500HD	6, 7, 19, 52	10"	4WD
DOUBLE FRONT SHOCK UPGRADE					
48139	2011-2013	DOUBLE FRONT HOOPS W/ BALL JOINT UPPER A ARMS	27, 41	10"	2WD/4WD
49841	2011-2013	BALL JOINT UPPER A ARMS	41	10"	2WD/4WD
C2045-625R	2011-2013	FTS 2.0 REMOTE RESERVOIR 4.5" TRAVEL CHROME FINISH (DOUBLE FRONT SHOCK)	29, 30	10"	2WD/4WD
B2045-625R	2011-2013	FTS 2.0 REMOTE RESERVOIR 4.5" TRAVEL BLACK FINISH (DOUBLE FRONT SHOCKS)	29, 31	10"	2WD/4WD
SINGLE FRONT SHOCK STOCK LOCATION					
C2010-625RUU	2011-2013	FTS 2.0 REMOTE RESERVOIR 10" TRAVEL CHROME FINISH (STOCK FRONT LOCATION)	29, 30	10"	2WD/4WD
B2010-625RUU	2011-2013	FTS 2.0 REMOTE RESERVOIR 10" TRAVEL BLACK FINISH (STOCK FRONT LOCATION)	29, 31	10"	2WD/4WD
SINGLE REAR SHOCK STOCK LOCATION					
C2012-625R	2011-2013	FTS 2.0 REMOTE RESERVOIR 12" TRAVEL CHROME FINISH (STOCK REAR LOCATION)	29, 30	10"	2WD/4WD
B2012-625R	2011-2013	FTS 2.0 REMOTE RESERVOIR 12" TRAVEL BLACK FINISH (STOCK REAR LOCATION)	29, 31	10"	2WD/4WD
PREMIUM DOUBLE REAR SHOCK BRACKET W/ UPPER CROSSMEMBER					
48159	2011-2013	DOUBLE REAR SHOCK CROSSMEMBER KIT	12, 18, 27	10"	2WD/4WD
C2014-625R	2011-2013	FTS 2.0 REMOTE RESERVOIR 14" TRAVEL CHROME FINISH (DOUBLE REAR SHOCK)	29, 30	10"	2WD/4WD
B2014-625R	2011-2013	FTS 2.0 REMOTE RESERVOIR 14" TRAVEL BLACK FINISH (DOUBLE RAR SHOCK)	29, 31	10"	2WD/4WD
ECONOMY DOUBLE REAR SHOCK BRACKET					
48151	2011-2013	DOUBLE REAR SHOCK BRACKET KIT	12, 18, 27	10"	2WD/4WD
C2011-625R	2011-2013	FTS 2.0 REMOTE RESERVOIR 11" TRAVEL CHROME FINISH	29, 30	10"	2WD/4WD
B2011-625R	2011-2013	FTS 2.0 REMOTE RESERVOIR 11" TRAVEL BLACK FINISH	29, 31	10"	2WD/4WD
BILLET SHOCK CLAMPS					
C2020	2011-2013	FTS 2.0 TO 2.0 BILLET SHOCK CLAMPS CHROME FINISH	38	10"	2WD/4WD
B2020	2011-2013	FTS 2.0 TO 2.0 BILLET SHOCK CLAMPS BLACK FINISH	38	10"	2WD/4WD
C2015	2011-2013	FTS 2.0 TO 1.5 BILLET SHOCK CLAMPS CHROME FINISH	38	10"	2WD/4WD
B2015	2011-2013	FTS 2.0 TO 1.5 BILLET SHOCK CLAMPS BLACK FINISH	38	10"	2WD/4WD
ACCESSORIES					
48132	2011-2013	FRONT / REAR STEEL BRAIDED BRAKE LINE KIT (DUAL REAR)	79	10"	2WD/4WD
48144	2011-2013	HEIMS JOINT STEERING W/ STEERING BAR	19, 22, 23	10"	2WD/4WD
48143	2011-2013	HEIMS JOINT STEERING CONVERSION KIT W/ U BRACKETS	19, 22, 23	10"	2WD/4WD
48246	2011-2013	DOUBLE FRONT STEERING STABILIZER KIT W/ BASIC HYDRAULIC STABILIZERS	56	10"	2WD/4WD
48247	2011-2013	DOUBLE FRONT STEERING STABILIZER KIT W/ FTS 2.0 CHROME STABILIZERS	30, 56	10"	2WD/4WD
48248	2011-2013	DOUBLE FRONT STEERING STABILIZER KIT W/ FTS 2.0 BLACK STABILIZERS	31, 56	10"	2WD/4WD
15963	2011-2013	BOLT ON TRACTION BAR KIT 63" (SHORT BED)	27, 56, 58	10"	2WD/4WD
15970	2011-2013	BOLT ON TRACTION BAR KIT 70" (LONG BED)	27, 56, 58	10"	2WD/4WD
48150	2011-2013	REAR AIR BAG KIT	27	10"	2WD/4WD
CBK30-720T	2011-2013	7.00" TAPERD BLOCK W/ 3/8" X 3.25 X 20" SQUARE U BOLTS	57	10"	2WD/4WD
CBK30-820T	2011-2013	8.00" TAPERD BLOCK W/ 3/8" X 3.25 X 20" SQUARE U BOLTS	57	10"	2WD/4WD
48411	2011-2013	IDLER ARM BRACE	18	10"	2WD/4WD
CVDL40	2011-2013	CV FRONT DRIVE SHAFT 40"	35, 47	10"	4WD
486500	2011-2013	UREA TANK SKID PLATE (DIESEL EXHAUST FLUID TANK)	56	10"	2WD/4WD
38316	2011-2013	2.5" TORSION KEY KIT	52	10"	2WD/4WD

15" 2011 - 2013 CHEVY / GMC 2500HD / 3500HD

2011-2013
15" CHEVY / GMC
2500HD / 3500HD TRUCK

Complete drop down kit and 100% bolt on
Structural crossmembers constructed of 1/4" thick steel for superior strength
Impact struts to distribute suspension impact throughout the frame
Additional support added to front differential to turn those huge tires
Does not extend track width or require any special wheel offset
Heavy duty semi gloss black powder for long life and great looks
Steering is dropped a full 15" for flat tie rod angles
Dual steering supports for superior steering control
Front differential dropped full 15" for flat C/V angles
C/V front driveshaft to eliminate vibration
No cutting of your factory frame



Max Recommended Tire Size 44"
Max Recommended Wheel Width 12"

Basic 2WD Kit includes:

- 15" Front Box Kit
- 13" Rear Springs and 2" Rear Block Kit
- Rear Drive Shaft Spacer
- Front / Rear Steel Braided Brake Lines

Basic 4WD Kit includes:

- 15" Front Box Kit
- 13" Rear Springs and 2" Rear Block Kit
- Rear Drive Shaft Spacer
- CV Front Drive Shaft
- Front / Rear Steel Braided Brake Lines

Shocks Sold Separately. Please see options below

PART #	YEAR	TITLE	FOOTNOTES	LIFT SIZE	2WD / 4WD
15" 2011-2013 CHEVY / GMC SILVERADO / SIERRA 2500HD / 3500HD					
49102	2011-2013	SILVERADO / SIERRA 2500HD / 3500HD	21, 19, 52	15"	2WD
49104	2011-2013	SILVERADO / SIERRA 2500HD / 3500HD	20, 19, 52	15"	4WD
DOUBLE FRONT SHOCK UPGRADE					
49140	2011-2013	DOUBLE FRONT SHOCK HOOPS W/ A ARM BRACKETS	27	15"	2WD/4WD
49139	2011-2013	DOUBLE FRONT HOOPS W/ BALL JOINT UPPER A ARMS	27, 41	15"	2WD/4WD
49141	2011-2013	BALL JOINT UPPER A ARMS	41	15"	2WD/4WD
C2012-625R	2011-2013	FTS 2.0 REMOTE RESERVOIR 12" TRAVEL CHROME FINISH (DOUBLE FRONT SHOCK)	29, 30	15"	2WD/4WD
B2012-625R	2011-2013	FTS 2.0 REMOTE RESERVOIR 12" TRAVEL BLACK FINISH (DOUBLE FRONT SHOCK)	29, 31	15"	2WD/4WD
C2510-875R	2011-2013	FTS 2.5 REMOTE RESERVOIR 10" TRAVEL CHROME FINISH (DOUBLE FRONT SHOCK)	29, 31	15"	2WD/4WD
B2510-875R	2011-2013	FTS 2.5 REMOTE RESERVOIR 10" TRAVEL BLACK FINISH (DOUBLE FRONT SHOCK)	29, 31	15"	2WD/4WD
SINGLE FRONT SHOCK STOCK LOCATION					
C2014-625RUU	2011-2013	FTS 2.0 REMOTE RESERVOIR 14" TRAVEL CHROME FINISH (STOCK FRONT LOCATION)	29, 30	15"	2WD/4WD
B2014-625RUU	2011-2013	FTS 2.0 REMOTE RESERVOIR 14" TRAVEL BLACK FINISH (STOCK FRONT LOCATION)	29, 31	15"	2WD/4WD
SINGLE REAR SHOCK STOCK LOCATION					
C2016-875R	2011-2013	FTS 2.0 REMOTE RESERVOIR 16" TRAVEL CHROME FINISH (STOCK REAR LOCATION)	29, 30	15"	2WD/4WD
B2016-875R	2011-2013	FTS 2.0 REMOTE RESERVOIR 16" TRAVEL BLACK FINISH (STOCK REAR LOCATION)	29, 31	15"	2WD/4WD
C2514-875R	2011-2013	FTS 2.5 REMOTE RESERVOIR 14" TRAVEL CHROME FINISH (DOUBLE FRONT SHOCK)	29, 31	15"	2WD/4WD
B2514-875R	2011-2013	FTS 2.5 REMOTE RESERVOIR 14" TRAVEL BLACK FINISH (DOUBLE FRONT SHOCK)	29, 31	15"	2WD/4WD
PREMIUM DOUBLE REAR SHOCK BRACKET W/ UPPER CROSSMEMBER					
48159	2011-2013	DOUBLE REAR SHOCK CROSSMEMBER KIT	12, 18, 27	15"	2WD/4WD
C2016-875R	2011-2013	FTS 2.0 REMOTE RESERVOIR 16" TRAVEL CHROME FINISH (DOUBLE REAR SHOCK)	29, 30	15"	2WD/4WD
B2016-875R	2011-2013	FTS 2.0 REMOTE RESERVOIR 16" TRAVEL BLACK FINISH (DOUBLE RAR SHOCK)	29, 31	15"	2WD/4WD
C2514-875R	2011-2013	FTS 2.5 REMOTE RESERVOIR 14" TRAVEL CHROME FINISH (DOUBLE FRONT SHOCK)	29, 31	15"	2WD/4WD
B2514-875R	2011-2013	FTS 2.5 REMOTE RESERVOIR 14" TRAVEL BLACK FINISH (DOUBLE FRONT SHOCK)	29, 31	15"	2WD/4WD
ECONOMY DOUBLE REAR SHOCK BRACKET					
49151	2011-2013	DOUBLE REAR SHOCK BRACKET KIT	12, 18, 27	15"	2WD/4WD
C2014-625R	2011-2013	FTS 2.0 REMOTE RESERVOIR 14" TRAVEL CHROME FINISH (DOUBLE REAR SHOCK)	29, 30	15"	2WD/4WD
B2014-625R	2011-2013	FTS 2.0 REMOTE RESERVOIR 14" TRAVEL BLACK FINISH (DOUBLE REAR SHOCK)	29, 31	15"	2WD/4WD
BILLET SHOCK CLAMPS					
C2020	2011-2013	FTS 2.0 TO 2.0 BILLET SHOCK CLAMPS CHROME FINISH	38	15"	2WD/4WD
B2020	2011-2013	FTS 2.0 TO 2.0 BILLET SHOCK CLAMPS BLACK FINISH	38	15"	2WD/4WD
C2525	2011-2013	FTS 2.5 TO 2.5 BILLET SHOCK CLAMPS CHROME FINISH	38	15"	2WD/4WD
B2525	2011-2013	FTS 2.5 TO 2.5 BILLET SHOCK CLAMPS BLACK FINISH	38	15"	2WD/4WD
ACCESSORIES					
49132	2011-2013	FRONT / REAR STEEL BRAIDED BRAKE LINE KIT (DUAL REAR)	79	15"	2WD/4WD
49143	2011-2013	HEIMS JOINT STEERING CONVERSION KIT W/ U BRACKETS	19, 22, 23	15"	2WD/4WD
49246	2011-2013	DOUBLE FRONT STEERING STABILIZER KIT W/ BASIC HYDRAULIC STABILIZERS	56	15"	2WD/4WD
49247	2011-2013	DOUBLE FRONT STEERING STABILIZER KIT W/ FTS 2.0 CHROME STABILIZERS	30, 56	15"	2WD/4WD
49248	2011-2013	DOUBLE FRONT STEERING STABILIZER KIT W/ FTS 2.0 BLACK STABILIZERS	31, 56	15"	2WD/4WD
15963	2011-2013	BOLT ON TRACTION BAR KIT 68" (SHORT BED)	27, 56, 58	15"	2WD/4WD
15968	2011-2013	BOLT ON TRACTION BAR KIT 74" (LONG BED)	27, 56, 58	15"	2WD/4WD
15974	2011-2013	REAR AIR BAG KIT (USE W/ 13" SPRINGS)	27	15"	2WD/4WD
48411	2011-2013	IDLER ARM BRACE	18	15"	2WD/4WD
CVDL40	2011-2013	CV FRONT DRIVE SHAFT 40"	35, 47	15"	4WD
CBK30-215T	2011-2013	2.00" TAPERD BLOCK W/ 3/4" X 3.25 X 15" SQUARE U BOLTS	57	15"	2WD/4WD
C11-8	2011-2013	8" REAR LEAF SPRINGS	57	15"	2WD/4WD
C11-13	2011-2013	13" REAR LEAF SPRINGS	55, 58	15"	2WD/4WD
1410	2011-2013	REAR DRIVE SHAFT SPACER GAS 1410	59, 60	15"	2WD/4WD
1480	2011-2013	REAR DRIVE SHAFT SPACER DIESEL 1480	59, 60	15"	2WD/4WD
38316	2011-2013	2.5" TORSION KEY KIT	52	15"	2WD/4WD
486500	2011-2013	UREA TANK SKID PLATE (DIESEL EXHAUST FLUID TANK)	56	15"	2WD/4WD

7" 1999 - 2006 CHEVY / GMC SILVERADO / SIERRA 1500

100% Bolt On 7" Spindle Kit
Utilizes ductile iron steering knuckle for stock alignment and superior driveability both on and offroad
Structural crossmembers constructed of 1/4" thick steel for superior strength
No cutting of your front differential
Front differential dropped full 7" for flat C/V angles
Heavy duty semi gloss black powder for long life and great looks
Impact struts to distribute suspension impact throughout the frame
Rear block kit with no add a leaf for fast installation and factory ride
Easy to install torsion bar relocation brackets



Max Recommended Tire Size 35" Max Recommended Wheel Width 10"

Basic 2WD kit includes:
7" Front Box Kit
6.25" Rear Block Kit
LH / RH Steering Knuckles
Basic 4WD kit includes:
7" Front Box Kit
6.25" Rear Block Kit
LH / RH Steering Knuckles
Shocks Sold Separately.
Please see options below

SILVERADO / SIERRA 1500 BASIC KIT
W/ REAR BLOCK KIT Part # 82105

PART #	YEAR	TITLE	FOOTNOTES	LIFT SIZE	2WD / 4WD
7" 1999-2006 CHEVY / GMC SILVERADO / SIERRA 1500 2WD					
82202	1999-2006	SILVERADO / SIERRA 1500 BASIC KIT W/ REAR BLOCKS	19	8"	2WD
82203	1999-2006	SILVERADO / SIERRA 1500 BASIC KIT W/ REAR SPRINGS	19	8"	2WD
7" 1999-2006 CHEVY / GMC SILVERADO / SIERRA 1500 4WD					
82104	1999-2006	SILVERADO / SIERRA 1500 BASIC KIT W/ REAR BLOCKS	4, 19, 52	7"	4WD
82105	1999-2006	SILVERADO / SIERRA 1500 BASIC KIT W/ REAR SPRINGS	4, 19, 52	7"	4WD
DOUBLE FRONT SHOCK UPGRADE					
82602	1999-2006	DOUBLE FRONT HOOPS W/ BALL JOINT UPPER A ARMS	27, 41	7"	4WD
85940	1999-2006	DOUBLE FRONT HOOPS (REQUIRES UPPER A ARM)	27	7"	4WD
82601	1999-2006	BALL JOINT UPPER A ARMS	41	7"	4WD
DOUBLE REAR SHOCK BRACKET					
85049	1999-2006	DOUBLE REAR SHOCK BRACKET KIT	12, 18, 27	7"	4WD
C2065-625R	1999-2006	FTS 2.0 REMOTE RESERVOIR 6.5" TRAVEL CHROME FINISH (DOUBLE FRONT SHOCK)	29, 30	7"	4WD
B2065-625R	1999-2006	FTS 2.0 REMOTE RESERVOIR 6.5" TRAVEL BLACK FINISH (DOUBLE FRONT SHOCK)	29, 31	7"	4WD
SINGLE FRONT SHOCK STOCK LOCATION					
C2010-625RSU	2000-2006	FTS 2.0 REMOTE RESERVOIR 10" TRAVEL CHROME FINISH (STOCK FRONT LOCATION)	29, 30	7"	4WD
B2010-625RSU	2000-2006	FTS 2.0 REMOTE RESERVOIR 10" TRAVEL BLACK FINISH (STOCK FRONT LOCATION)	29, 31	7"	4WD
SINGLE REAR SHOCK STOCK LOCATION					
C2012-625R	1999-2006	FTS 2.0 REMOTE RESERVOIR 12" TRAVEL CHROME FINISH (SINGLE REAR SHOCK)	29, 30	7"	2WD / 4WD
B2012-625R	1999-2006	FTS 2.0 REMOTE RESERVOIR 12" TRAVEL BLACK FINISH (SINGLE REAR SHOCK)	29, 31	7"	2WD / 4WD
BILLET SHOCK CLAMPS					
C2020	1999-2006	FTS 2.0 BILLET SHOCK CLAMPS CHROME FINISH	38	7"	2WD / 4WD
B2020	1999-2006	FTS 2.0 BILLET SHOCK CLAMPS BLACK FINISH	38	7"	2WD / 4WD
ACCESSORIES					
85022	1999-2006	FRONT / REAR STEEL BRAIDED BRAKE LINE KIT (SINGLE REAR)	79	7"	2WD / 4WD
85443	1999-2006	HEAVY DUTY HEIMS JOINT STEERING W/ U BRACKETS	19, 22, 23	7"	4WD
85444	1999-2006	HEIMS JOINT STEERING W/ STEERING BAR	19, 22, 23	7"	4WD
85946	1999-2006	DOUBLE FRONT STEERING STABILIZER KIT W/ BASIC HYDRAULIC STABILIZERS	56	7"	4WD
12960	1999-2006	BOLT ON TRACTION BAR KIT 60" (SHORT BED)	27, 56, 58	7"	2WD / 4WD
12968	1999-2006	BOLT ON TRACTION BAR KIT 68" (LONG BED)	27, 56, 58	7"	2WD / 4WD
85050	1999-2006	REAR AIR BAG KIT (USE W/ STOCK SPRINGS)	27, 56	7"	2WD / 4WD
85051	1999-2006	REAR AIR BAG KIT (USE W/ FTS 7" SPRINGS)	27, 56	7"	2WD / 4WD
CBK25-525T	1999-2010	5.25" TAPERED BLOCK W/9/16 X 2.5 X 14" SQUARE U BOLTS	22, 25	7"	2WD / 4WD
CBK25-625T	1999-2010	6.25" TAPERED BLOCK W/9/16 X 2.5 X 15.5" SQUARE U BOLTS	22, 25	7"	2WD / 4WD
C7	1999-2006	7" REAR LEAF SPRINGS	55	7"	2WD / 4WD
85451	1999-2006	IDLER ARM BRACE	18	7"	4WD
38303	1999-2006	2" TORSION KEYS	52	7"	4WD



7" 2000 - 2006 TAHOE / SUBURBAN / AVALANCHE / YUKON / ESCALADE / DENALI

4WD TAHOE / AVALANCHE / SUBURBAN
YUKON BASIC KIT Part #82108



PART #	YEAR	TITLE	FOOTNOTES	LIFT SIZE	2WD / 4WD
7" 2000-2006 CHEVY / GMC ESCALADE / DENALI / TAHOE / SUBURBAN / YUKON					
82107	2000-2006	ESCALADE / DENALI BASIC KIT	4, 19, 52	7"	2WD
82109	2000-2006	ESCALADE / DENALI BASIC KIT *INCLUDES CV FRONT DRIVE SHAFT	4, 19, 35, 37, 52	7"	4WD
82106	2000-2006	TAHOE / AVALANCHE / SUBURBAN / YUKON BASIC KIT	4, 19, 52	7"	2WD
82108	2000-2006	TAHOE / AVALANCHE / SUBURBAN / YUKON BASIC KIT	4, 19, 52	7"	4WD
DOUBLE FRONT SHOCK UPGRADE					
82602	2000-2006	DOUBLE FRONT HOOPS W/ BALL JOINT UPPER A ARMS	27, 41	7"	2WD / 4WD
85940	2000-2006	DOUBLE FRONT HOOPS *REQUIRES UPPER A ARM	27	7"	2WD / 4WD
82601	2000-2006	BALL JOINT UPPER A ARMS	41	7"	2WD / 4WD
C2065-625R	2000-2006	FTS 2.0 REMOTE RESERVOIR 6.5" TRAVEL CHROME FINISH (DOUBLE FRONT SHOCK)	29, 30	7"	2WD / 4WD
B2065-625R	2000-2006	FTS 2.0 REMOTE RESERVOIR 6.5" TRAVEL BLACK FINISH (DOUBLE FRONT SHOCK)	29, 31	7"	2WD / 4WD
SINGLE FRONT SHOCK STOCK LOCATION					
C2010-625RSU	2000-2006	FTS 2.0 REMOTE RESERVOIR 10" TRAVEL CHROME FINISH (STOCK FRONT LOCATION)	29, 30	7"	2WD / 4WD
B2010-625RSU	2000-2006	FTS 2.0 REMOTE RESERVOIR 10" TRAVEL BLACK FINISH (STOCK FRONT LOCATION)	29, 31	7"	2WD / 4WD
SINGLE REAR SHOCK STOCK LOCATION					
C2012-625R	2000-2006	FTS 2.0 REMOTE RESERVOIR 12" TRAVEL CHROME FINISH	29, 30	7"	2WD / 4WD
B2012-625R	2000-2006	FTS 2.0 REMOTE RESERVOIR 12" TRAVEL BLACK FINISH	29, 31	7"	2WD / 4WD
BILLET SHOCK CLAMPS					
C2020	2000-2006	FTS 2.0 BILLET SHOCK CLAMPS CHROME FINISH	38	7"	2WD / 4WD
B2020	2000-2006	FTS 2.0 BILLET SHOCK CLAMPS BLACK FINISH	38	7"	2WD / 4WD
ACCESSORIES					
85022	2000-2006	FRONT / REAR STEEL BRAIDED BRAKE LINE KIT (SINGLE REAR)	79	7"	2WD / 4WD
85443	2000-2006	HEAVY DUTY HEIMS JOINT STEERING W/ U BRACKETS	19, 22, 23	7"	2WD / 4WD
85444	2000-2006	HEIMS JOINT STEERING W/ STEERING BAR	19, 22, 23	7"	2WD / 4WD
85946	2000-2006	DOUBLE FRONT STEERING STABILIZER KIT W/ BASIC HYDRAULIC STABILIZERS	19, 22, 23	7"	2WD / 4WD
85451	2000-2006	IDLER ARM BRACE	18	7"	2WD / 4WD
82123	2000-2006	7" REAR SUV BOX KIT	56	7"	2WD / 4WD
85060	2000-2006	REAR LOWER TRAILING ARMS	69	7"	2WD / 4WD
85061	2000-2006	REAR TUBULAR TRACK BAR	68	7"	2WD / 4WD
85064	2000-2006	REAR HEIMS JOINT SWAY BAR ENLINK KIT	56	7"	2WD / 4WD
CVDL38	2000-2006	CV FRONT DRIVE SHAFT 38"	35	7"	4WD
38303	2000-2006	2" TORSION KEYS	52	7"	2WD / 4WD

9.5" 1999 - 2006 CHEVY / GMC SILVERADO / SIERRA 1500

1999-2006
CHEVY / GMC
1500 TRUCK AND SUV

Complete drop down kit and 100% bolt on
Full drop down kit with no wheel clearance restrictions
Front differential dropped full 9.5" for flat C/V angles
Upgraded long travel steering included with kit along with 3rd idler arm
No permanent modification to differential housing required for installation
Impact struts to distribute suspension impact throughout the frame
C/V front driveshaft to eliminate vibration
Heavy duty semi gloss black powder for long life and great looks
Easy to install torsion bar relocation brackets
Maintains factory control arm geometry for factory ride and alignment
Structural crossmembers constructed of 1/4" thick steel for superior strength
Upgraded alignment cams with added travel for precise alignment



Basic 4WD Truck Kit Includes:
9.5" Front Box Kit
10" Rear Springs
Front / Rear Steel Braided Brake Lines
CV Front Drive Shaft
Basic 2WD SUV Kit Includes:
9.5" Front Box Kit
10" Rear Box Kit
Front / Rear Steel Braided Brake Lines
Basic 4WD SUV Kit Includes:
9.5" Front Box Kit
10" Rear Box Kit
Front / Rear Steel Braided Brake Lines
CV Front Drive Shaft
Shocks Sold Separately.
Please see options below

Max Recommended Tire Size 37" Max Recommended Wheel Width 10"

PART #	YEAR	TITLE	FOOTNOTES	LIFT SIZE	2WD / 4WD
9.5" 1999-2006 CHEVY / GMC SILVERADO / SIERRA 1500					
82202	1999-2006	SILVERADO / SIERRA 1500 BASIC KIT	1, 19, 52	9.5"	4WD
FRONT SHOCK UPGRADE					
85410	1999-2006	DOUBLE FRONT HOOPS W/ BALL JOINT UPPER A ARMS	27, 41	9.5"	4WD
85416	1999-2006	DOUBLE FRONT HOOPS W/ UNIBALL UPPER A ARMS	27, 40	9.5"	4WD
85440	1999-2006	DOUBLE FRONT HOOPS W/ UPPER A ARMS BRACKETS	27	9.5"	4WD
85441	1999-2006	BALL JOINT UPPER A ARMS	41	9.5"	4WD
85442	1999-2006	UNI BALL UPPER A ARMS	40, 41	9.5"	4WD
C2085-625R	1999-2006	FTS 2.0 REMOTE RESERVOIR 8.5" TRAVEL CHROME FINISH (DOUBLE FRONT SHOCK)	29, 30	9.5"	4WD
B2085-625R	1999-2006	FTS 2.0 REMOTE RESERVOIR 8.5" TRAVEL BLACK FINISH (DOUBLE FRONT SHOCK)	29, 31	9.5"	4WD
DOUBLE REAR SHOCK BRACKET					
85449	1999-2006	DOUBLE REAR SHOCK BRACKET KIT	12, 18, 27	9.5"	4WD
C2010-625R	1999-2006	FTS 2.0 REMOTE RESERVOIR 10" TRAVEL CHROME FINISH (DOUBLE REAR SHOCK)	29, 30	9.5"	4WD
B2010-625R	1999-2006	FTS 2.0 REMOTE RESERVOIR 10" TRAVEL BLACK FINISH (DOUBLE REAR SHOCK)	29, 31	9.5"	4WD
SINGLE FRONT SHOCK STOCK LOCATION					
C2010-625RSU	1999-2006	FTS 2.0 REMOTE RESERVOIR 10" TRAVEL CHROME FINISH	29, 30	9.5"	4WD
B2010-625RSU	1999-2006	FTS 2.0 REMOTE RESERVOIR 10" TRAVEL BLACK FINISH	29, 31	9.5"	4WD
SINGLE REAR SHOCK STOCK LOCATION					
C2012-625R	1999-2006	FTS 2.0 REMOTE RESERVOIR 12" TRAVEL CHROME FINISH	29, 30	9.5"	4WD
B2012-625R	1999-2006	FTS 2.0 REMOTE RESERVOIR 12" TRAVEL BLACK FINISH (SINGLE REAR SHOCK)	29, 31	9.5"	4WD
BILLET SHOCK CLAMPS					
C2020	1999-2006	FTS 2.0 BILLET SHOCK CLAMPS CHROME FINISH	38	9.5"	4WD
B2020	1999-2006	FTS 2.0 BILLET SHOCK CLAMPS BLACK FINISH	38	9.5"	4WD
ACCESSORIES					
85222	1999-2006	FRONT / REAR STEEL BRAIDED BRAKE LINE KIT (SINGLE REAR)	79	9.5"	4WD
84843	1999-2006	HEAVY DUTY HEIMS JOINT STEERING KIT	19, 22, 23	9.5"	4WD
85246	1999-2006	DOUBLE FRONT STEERING STABILIZER KIT W/ BASIC HYDRAULIC STABILIZERS	56	9.5"	4WD
12960	1999-2006	BOLT ON TRACTION BAR KIT 60" (SHORT BED)	27, 56, 58	9.5"	4WD
12968	1999-2006	BOLT ON TRACTION BAR KIT 68" (LONG BED)	27, 56, 58	9.5"	4WD
85250	1999-2006	REAR AIR BAG KIT (USE W/ FTS 10" SPRINGS)	27, 56	9.5"	4WD
C10	1999-2006	10" REAR LEAF SPRINGS	55	9.5"	4WD
85451	1999-2006	IDLER ARM BRACE	18	9.5"	4WD
CVDL38	1999-2006	CV FRONT DRIVE SHAFT 38"	35	9.5"	4WD
38303	1999-2006	2" TORSION KEYS	52	9.5"	4WD
3R	1999-2006	2" REAR DRIVE SHAFT SPACER 3R	59, 60	9.5"	4WD
1350	1999-2006	2" REAR DRIVE SHAFT SPACER 1350	59, 60	9.5"	4WD
85800	1999-2006	DIFFERENTIAL EAR REPLACEMENT BRACKET	27, 44	9.5"	4WD

SILVERADO / SIERRA 1500 BASIC KIT
W/ REAR SPRINGS Part # 82202

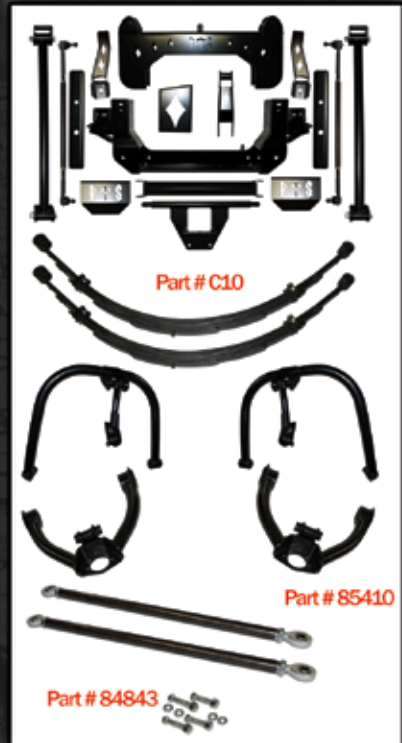

9.5" 2000 - 2006 TAHOE / SUBURBAN / AVALANCHE / YUKON / ESCALADE / DENALI



TAHOE / AVALANCHE / SUBURBAN / YUKON
BASIC KIT Part #84515

PART #	YEAR	TITLE	FOOTNOTES	LIFT SIZE	2WD / 4WD
9.5" 2000-2006 CHEVY / GMC ESCALADE / DENALI / TAHOE / SUBURBAN / AVALANCHE / YUKON					
84512	2000-2006	TAHOE / SUBURBAN / AVALANCHE / YUKON 1500 BASIC KIT	9, 19, 52	9.5"	2WD
84515	2000-2006	TAHOE / SUBURBAN / AVALANCHE / YUKON 1500 BASIC KIT *INCLUDES CV FRONT DRIVE SHAFT	7, 19, 52	9.5"	4WD
DOUBLE FRONT SHOCK UPGRADE					
85410	2000-2006	DOUBLE FRONT HOOPS W/ BALL JOINT UPPER A ARMS	27, 41	9.5"	2WD / 4WD
85416	2000-2006	DOUBLE FRONT HOOPS W/ UNIBALL UPPER A ARMS	27, 40	9.5"	2WD / 4WD
85440	2000-2006	DOUBLE FRONT HOOPS W/ UPPER A ARMS BRACKETS	27	9.5"	2WD / 4WD
85441	2000-2006	BALL JOINT UPPER A ARMS	41	9.5"	2WD / 4WD
85442	2000-2006	UNI BALL UPPER A ARMS	40, 41	9.5"	2WD / 4WD
C2085-625R	2000-2006	FTS 2.0 REMOTE RESERVOIR 8.5" TRAVEL CHROME FINISH (DOUBLE FRONT SHOCK)	29, 30	9.5"	2WD / 4WD
B2085-625R	2000-2006	FTS 2.0 REMOTE RESERVOIR 8.5" TRAVEL BLACK FINISH (DOUBLE FRONT SHOCK)	29, 31	9.5"	2WD / 4WD
SINGLE FRONT SHOCK STOCK LOCATION					
C2010-625RSU	2000-2006	FTS 2.0 REMOTE RESERVOIR 10" TRAVEL CHROME FINISH (STOCK FRONT LOCATION)	29, 30	9.5"	2WD / 4WD
B2010-625RSU	2000-2006	FTS 2.0 REMOTE RESERVOIR 10" TRAVEL BLACK FINISH	29, 31	9.5"	2WD / 4WD
SINGLE REAR SHOCK STOCK LOCATION					
C2012-625R	2000-2006	FTS 2.0 REMOTE RESERVOIR 12" TRAVEL CHROME FINISH (SINGLE REAR SHOCK)	29, 30	9.5"	2WD / 4WD
B2012-625R	2000-2006	FTS 2.0 REMOTE RESERVOIR 12" TRAVEL BLACK FINISH (SINGLE REAR SHOCK)	29, 31	9.5"	2WD / 4WD
BILLET SHOCK CLAMPS					
C2020	2000-2006	FTS 2.0 BILLET SHOCK CLAMPS CHROME FINISH	38	9.5"	2WD / 4WD
B2020	2000-2006	FTS 2.0 BILLET SHOCK CLAMPS BLACK FINISH	38	9.5"	2WD / 4WD
ACCESSORIES					
85222	2000-2006	FRONT / REAR STEEL BRAIDED BRAKE LINE KIT (SINGLE REAR)	79	9.5"	2WD / 4WD
84843	2000-2006	HEAVY DUTY HEIMS JOINT STEERING KIT	19, 22, 23	9.5"	2WD / 4WD
85564	2000-2006	REAR HEIMS JOINT SWAY BAR ENDLINK KIT	56	9.5"	2WD / 4WD
85246	2000-2006	DOUBLE FRONT STEERING STABILIZER KIT W/ BASIC HYDRAULIC STABILIZERS	56	9.5"	2WD / 4WD
85451	2000-2006	IDLER ARM BRACE	18	9.5"	2WD / 4WD
85060	2000-2006	REAR TUBULAR TRAILING ARMS	68	9.5"	2WD / 4WD
84508	2000-2006	9.5" REAR SUV BOX KIT	48, 56	9.5"	2WD / 4WD
85061	2000-2006	REAR TUBULAR TRACK BARS	68	9.5"	2WD / 4WD
38303	2000-2006	2" TORSION KEYS	52	9.5"	2WD / 4WD
CVDL38	2000-2006	CV FRONT DRIVE SHAFT 38"	35	9.5"	4WD
85800	1999-2006	DIFFERENTIAL EAR REPLACEMENT BRACKET	27, 44	9.5"	4WD

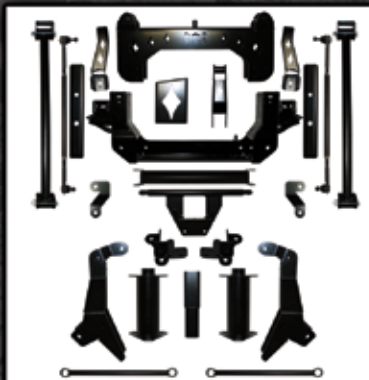

12" 1999 - 2006 CHEVY / GMC SILVERADO / SIERRA 1500

Complete drop down kit and 100% bolt on
Full drop down kit with no wheel clearance restrictions
Front differential dropped full 12" for flat C/V angles
Upgraded long travel steering included with kit along with 3rd idler arm
No permanent modification to differential housing required for installation
Impact struts to distribute suspension impact throughout the frame
C/V front driveshaft to eliminate vibration
Heavy duty semi gloss black powder for long life and great looks
Easy to install torsion bar relocation brackets
Maintains factory control arm geometry for factory ride and alignment
Max Recommended Tire Size 39" Max Recommended Wheel Width 10"



Basic 2WD kit includes:
12" Front Box Kit
12" Rear Springs
Rear Drive Shaft Spacer
Front / Rear Steel Braided Brake Lines
Basic 4WD kit includes:
12" Front Box Kit
12" Rear Springs
Rear Drive Shaft Spacer
CV Front Drive Shaft
Front / Rear Steel Braided Brake Lines
Shocks Sold Separately.
Please see options below

PART #	YEAR	TITLE	FOOTNOTES	LIFT SIZE	2WD / 4WD
12" 1999-2006 CHEVY / GMC SILVERADO / SIERRA 1500					
85501	1999-2006	SILVERADO / SIERRA 1500 BASIC KIT *INCLUDES CV FRONT DRIVE SHAFT	19, 20, 52	12"	4WD
85590	1999-2006	SILVERADO / SIERRA 1500 BASIC KIT W/ COILOVERS	19	12"	2WD
DOUBLE FRONT SHOCK UPGRADE					
85410	1999-2006	DOUBLE FRONT HOOPS W/ BALL JOINT UPPER A ARMS (WILL NOT FIT 2WD)	27, 41	12"	4WD
85416	1999-2006	DOUBLE FRONT HOOPS W/ UNIBALL UPPER A ARMS (WILL NOT FIT 2WD)	27, 40	12"	4WD
85440	1999-2006	DOUBLE FRONT HOOPS W/ UPPER A ARMS BRACKETS (WILL NOT FIT 2WD)	27	12"	4WD
85441	1999-2006	BALL JOINT UPPER A ARMS	41	12"	4WD
85442	1999-2006	UNI BALL UPPER A ARMS	40, 41	12"	4WD
C2010-625R	1999-2006	FTS 2.0 REMOTE RESERVOIR 10" TRAVEL CHROME FINISH (DOUBLE FRONT SHOCK)	29, 30	12"	4WD
B2010-625R	1999-2006	FTS 2.0 REMOTE RESERVOIR 10" TRAVEL BLACK FINISH (DOUBLE FRONT SHOCK)	29, 30	12"	4WD
SINGLE FRONT SHOCK STOCK LOCATION					
C2011-625RSU	1999-2006	FTS 2.0 REMOTE RESERVOIR 12" TRAVEL CHROME FINISH (STOCK FRONT LOCATION)	29, 30	12"	4WD
B2011-625RSU	1999-2006	FTS 2.0 REMOTE RESERVOIR 11" TRAVEL BLACK FINISH (STOCK FRONT LOCATION)	29, 31	12"	4WD
DOUBLE REAR SHOCK BRACKET					
85449	1999-2006	DOUBLE REAR SHOCK BRACKET KIT	12, 18, 27	12"	2WD/4WD
C2011-625R	1999-2006	FTS 2.0 REMOTE RESERVOIR 11" TRAVEL CHROME FINISH (DOUBLE REAR SHOCK)	29, 30	12"	2WD/4WD
B2011-625R	1999-2006	FTS 2.0 REMOTE RESERVOIR 11" TRAVEL BLACK FINISH (DOUBLE REAR SHOCK)	29, 31	12"	2WD/4WD
SINGLE REAR SHOCK STOCK LOCATION					
C2014-625R	1999-2006	FTS 2.0 REMOTE RESERVOIR 14" TRAVEL CHROME FINISH (STOCK REAR LOCATION)	29, 30	12"	2WD/4WD
B2014-625R	1999-2006	FTS 2.0 REMOTE RESERVOIR 14" TRAVEL BLACK FINISH (STOCK REAR LOCATION)	29, 31	12"	2WD/4WD
BILLET SHOCK CLAMPS					
C2020	1999-2006	FTS 2.0 BILLET SHOCK CLAMPS CHROME FINISH	38	12"	2WD/4WD
B2020	1999-2006	FTS 2.0 BILLET SHOCK CLAMPS BLACK FINISH	38	12"	2WD/4WD
ACCESSORIES					
85222	1999-2006	FRONT / REAR STEEL BRAIDED BRAKE LINE KIT (SINGLE REAR)	79	12"	2WD/4WD
84843	1999-2006	HEAVY DUTY HEIMS JOINT STEERING KIT	19, 22, 23	12"	4WD
85246	1999-2006	DOUBLE FRONT STEERING STABILIZER KIT W/ BASIC HYDRAULIC STABILIZERS	56	12"	4WD
12963	1999-2006	BOLT ON TRACTION BAR KIT 63" (SHORT BED)	27, 56, 58	12"	2WD/4WD
12972	1999-2006	BOLT ON TRACTION BAR KIT 72" (LONG BED)	27, 56, 58	12"	2WD/4WD
85250	1999-2006	REAR AIR BAG KIT (USE W/ FTS 12" SPRINGS)	27, 56	12"	2WD/4WD
C12	1999-2006	12" REAR LEAF SPRINGS	55	12"	2WD/4WD
85451	1999-2006	IDLER ARM BRACE	18	12"	4WD
CVDL38	1999-2006	CV FRONT DRIVE SHAFT 38"	35	12"	4WD
38303	1999-2006	2" TORSION KEYS	52	12"	4WD
3R	1999-2006	2" REAR DRIVE SHAFT SPACER 3R	59, 60	12"	2WD/4WD
1350	1999-2006	2" REAR DRIVE SHAFT SPACER 1350	59, 60	12"	2WD/4WD
85800	1999-2006	DIFFERENTIAL EAR REPLACEMENT BRACKET	27, 44	12"	4WD

SILVERADO / SIERRA 1500 BASIC KIT
Part #85501



12" 2000 - 2006 TAHOE / SUBURBAN / AVALANCHE / YUKON / ESCALADE / DENALI



TAHOE / SUBURBAN
AVALANCHE / YUKON BASIC KIT
Part # 85503



PART #	YEAR	TITLE	FOOTNOTES	LIFT SIZE	2WD / 4WD
12" 2000-2006 CHEVY / GMC ESCALADE / DENALI / TAHOE / SUBURBAN / AVALANCHE / YUKON					
85502	2000-2006	TAHOE / SUBURBAN / AVALANCHE / YUKON 1500 BASIC KIT	19, 36, 52	12"	2WD
85503	2000-2006	TAHOE / SUBURBAN / AVALANCHE / YUKON 1500 BASIC KIT *INCLUDES CV FRONT DRIVE SHAFT	19, 28, 52	12"	4WD
DOUBLE FRONT SHOCK UPGRADE					
85410	2000-2006	DOUBLE FRONT HOOPS W/ BALL JOINT UPPER A ARMS	27, 41	12"	2WD / 4WD
85416	2000-2006	DOUBLE FRONT HOOPS W/ UNIBALL UPPER A ARMS	27, 40	12"	2WD / 4WD
85440	2000-2006	DOUBLE FRONT HOOPS W/ UPPER A ARMS BRACKETS	27	12"	2WD / 4WD
85441	2000-2006	BALL JOINT UPPER A ARMS	41	12"	2WD / 4WD
85442	2000-2006	UNI BALL UPPER A ARMS	40, 41	12"	2WD / 4WD
C2010-625R	2000-2006	FTS 2.0 REMOTE RESERVOIR 10" TRAVEL CHROME FINISH (DOUBLE FRONT SHOCK)	29, 30	12"	2WD / 4WD
B2010-625R	2000-2006	FTS 2.0 REMOTE RESERVOIR 10" TRAVEL BLACK FINISH (DOUBLE FRONT SHOCK)	29, 31	12"	2WD / 4WD
SINGLE FRONT SHOCK STOCK LOCATION					
C2011-625RSU	2000-2006	FTS 2.0 REMOTE RESERVOIR 11" TRAVEL CHROME FINISH	29, 30	12"	2WD / 4WD
B2011-625RSU	2000-2006	FTS 2.0 REMOTE RESERVOIR 11" TRAVEL BLACK FINISH	29, 31	12"	2WD / 4WD
SINGLE REAR SHOCK STOCK LOCATION					
C2014-625R	2000-2006	FTS 2.0 REMOTE RESERVOIR 14" TRAVEL CHROME FINISH	29, 30	12"	2WD / 4WD
B2014-625R	2000-2006	FTS 2.0 REMOTE RESERVOIR 14" TRAVEL BLACK FINISH	29, 31	12"	2WD / 4WD
BILLET SHOCK CLAMPS					
C2020	2000-2006	FTS 2.0 BILLET SHOCK CLAMPS CHROME FINISH	38	12"	2WD / 4WD
B2020	2000-2006	FTS 2.0 BILLET SHOCK CLAMPS BLACK FINISH	38	12"	2WD / 4WD
ACCESSORIES					
85222	2000-2006	FRONT / REAR STEEL BRAIDED BRAKE LINE KIT (SINGLE REAR)	79	12"	2WD / 4WD
84843	2000-2006	HEAVY DUTY HEIMS JOINT STEERING KIT	19, 22, 23	12"	2WD / 4WD
85246	2000-2006	DOUBLE FRONT STEERING STABILIZER KIT W/ BASIC HYDRAULIC STABILIZERS	56	12"	2WD / 4WD
85564	2000-2006	REAR HEIMS JOINT SWAY BAR ENLINK KIT	56	12"	2WD / 4WD
85508	2000-2006	12" REAR SUV BOX KIT	48, 56	12"	2WD/4WD
85451	2000-2006	IDLER ARM BRACE	18	12"	2WD / 4WD
CVDL38	2000-2006	CV FRONT DRIVE SHAFT 38"	35	12"	4WD
38303	2000-2006	2" TORSION KEYS	52	12"	2WD / 4WD
85060	2000-2006	REAR TUBULAR TRAILING ARMS	68	12"	2WD/4WD
85061	2000-2006	REAR TUBULAR TRACK BARS	68	12"	2WD/4WD
3R	2000-2006	2" REAR DRIVE SHAFT SPACER 3R	59, 60	12"	2WD/4WD
1350	2000-2006	2" REAR DRIVE SHAFT SPACER 1350	59, 60	12"	2WD/4WD
85800	1999-2006	DIFFERENTIAL EAR REPLACEMENT BRACKET	27, 44	12"	4WD

15-18" 1999 - 2006 CHEVY / GMC SILVERADO / SIERRA 1500

15" INCH
18" INCH
1500 TRUCK AND SUV
1999-2006 CHEVY / GMC

Complete drop down kit and 100% bolt on
Full drop down kit with no wheel clearance restrictions
Front differential dropped full amount for flat C/V angles
Upgraded long travel steering included with kit along with 3rd idler arm
No permanent modification to differential housing required for installation
Impact struts to distribute suspension impact throughout the frame
C/V front driveshaft to eliminate vibration
Heavy duty semi gloss black powder for long life and great looks
Easy to install torsion bar relocation brackets
Maintains factory control arm geometry for factory ride and alignment
Structural crossmembers constructed of 1/4" thick steel for superior strength
Upgraded alignment cams with added travel for precise alignment



Basic 4WD Truck Kit Includes:
15" Front Box Kit
12" Rear Springs & 3" Rear Block Kit
Cv Front Drive Shaft
Rear Drive Shaft Spacer
Front/ Rear Steel Braided Brake Lines

Basic 4WD Truck Kit Includes:
18" Front Box Kit
12" Rear Springs & 6" Rear Block Kit
Cv Front Drive Shaft
Rear Drive Shaft Spacer
Front/ Rear Steel Braided Brake Lines

15" Kit Max Recommended Tire Size 40" Max Recommended Wheel Width 10"
18" Kit Max Recommended Tire Size 44" Max Recommended Wheel Width 10"

Shocks Sold Separately.
Please see options below

PART #	YEAR	TITLE	FOOTNOTES	LIFT SIZE	2WD / 4WD
15"/18" 1999-2006 CHEVY / GMC SILVERADO / SIERRA 1500					
85601	1999-2006	SILVERADO / SIERRA 1500 BASIC KIT *INCLUDES CV FRONT DRIVE SHAFT		19, 20, 39, 52	15" 4WD
85701	1999-2006	SILVERADO / SIERRA 1500 BASIC KIT *INCLUDES CV FRONT DRIVE SHAFT		19, 20, 39, 52	18" 4WD
DOUBLE FRONT SHOCK UPGRADE					
85410	1999-2006	DOUBLE FRONT HOOPS W/ BALL JOINT UPPER A ARMS		27, 41	15"/18" 4WD
85440	1999-2006	DOUBLE FRONT HOOPS W/ UNIBALL UPPER A ARMS		27, 40	15"/18" 4WD
85416	1999-2006	DOUBLE FRONT HOOPS W/ UPPER A ARMS BRACKETS		27	15"/18" 4WD
85441	1999-2006	BALL JOINT UPPER A ARMS		41	15"/18" 4WD
85442	1999-2006	UNI BALL UPPER A ARMS		40, 41	15"/18" 4WD
C2011-625R	1999-2006	FTS 2.0 REMOTE RESERVOIR 11" TRAVEL CHROME FINISH (DOUBLE FRONT SHOCK)		29, 30	15" 2WD / 4WD
B2011-625R	1999-2006	FTS 2.0 REMOTE RESERVOIR 11" TRAVEL BLACK FINISH (DOUBLE FRONT SHOCK)		29, 31	15" 2WD / 4WD
C2012-625R	1999-2006	FTS 2.0 REMOTE RESERVOIR 12" TRAVEL CHROME FINISH (DOUBLE FRONT SHOCK)		29, 30	18" 2WD / 4WD
B2012-625R	1999-2006	FTS 2.0 REMOTE RESERVOIR 12" TRAVEL BLACK FINISH (DOUBLE FRONT SHOCK)		29, 31	18" 2WD / 4WD
DOUBLE REAR SHOCK BRACKET					
85449	1999-2006	DOUBLE REAR SHOCK BRACKET KIT		12, 18, 27	15"/18" 4WD
C2014-625R	1999-2006	FTS 2.0 REMOTE RESERVOIR 14" TRAVEL CHROME FINISH (DOUBLE REAR SHOCK)		29, 30	15"/18" 4WD
B2014-625R	1999-2006	FTS 2.0 REMOTE RESERVOIR 14" TRAVEL BLACK FINISH (DOUBLE REAR SHOCK)		29, 31	15"/18" 4WD
SINGLE REAR SHOCK STOCK LOCATION					
C2016-875R	1999-2006	FTS 2.0 REMOTE RESERVOIR 16" TRAVEL CHROME FINISH (STOCK REAR LOCATION)		29, 30, 54	15"/18" 4WD
B2016-875R	1999-2006	FTS 2.0 REMOTE RESERVOIR 16" TRAVEL BLACK FINISH (STOCK REAR LOCATION)		29, 31, 54	15"/18" 4WD
BILLET SHOCK CLAMPS					
C2020	1999-2006	FTS 2.0 TO 2.0 BILLET SHOCK CLAMPS CHROME FINISH		38	15"/18" 4WD
B2020	1999-2006	FTS 2.0 TO 2.0 BILLET SHOCK CLAMPS BLACK FINISH		38	15"/18" 4WD
ACCESSORIES					
85622	1999-2006	FRONT / REAR STEEL BRAIDED BRAKE LINE KIT (SINGLE REAR)		79	15"/18" 4WD
84843	1999-2006	HEAVY DUTY HEIMS JOINT STEERING KIT		19, 22, 23	15"/18" 4WD
85246	1999-2006	DOUBLE FRONT STEERING STABILIZER KIT W/ BASIC HYDRAULIC STABILIZERS		56	15"/18" 4WD
12974	1999-2006	BOLT ON TRACTION BAR KIT 74" (SHORT BED)		27, 56, 58	15"/18" 4WD
12978	1999-2006	BOLT ON TRACTION BAR KIT 78" (LONG BED)		27, 56, 58	15"/18" 4WD
85350	1999-2006	REAR AIR BAG KIT (USE W/ FTS 12" REAR SPRINGS)		27, 56	15"/18" 4WD
C12	1999-2006	12" REAR LEAF SPRINGS		55	15"/18" 4WD
C15	1999-2006	15" REAR LEAF SPRINGS		55	15"/18" 4WD
85451	1999-2006	IDLER ARM BRACE		18	15"/18" 4WD
CVDL40	1999-2006	CV FRONT DRIVE SHAFT 40"		35	15"/18" 4WD
38303	1999-2006	2" TORSION KEYS		52	15"/18" 4WD
3R	1999-2006	2" REAR DRIVE SHAFT SPACER 3R		59, 60	15"/18" 4WD
1350	1999-2006	2" REAR DRIVE SHAFT SPACER 1350		59, 60	15"/18" 4WD
85800	1999-2006	DIFFERENTIAL EAR REPLACEMENT BRACKET		27, 44	15"/18" 4WD

15" SILVERADO / SIERRA 1500
BASIC KIT Part #85601



18" SILVERADO / SIERRA 1500
BASIC KIT Part #85701



15-18" 2000 - 2006 TAHOE / SUBURBAN / AVALANCHE / YUKON / ESCALADE / DENALI

Basic 2WD SUV Kit Includes:
15" Front Box Kit
15" Rear Box Kit
Rear Drive Shaft Spacer
Front/ Rear Steel Braided Brake Lines

Basic 4WD SUV Kit Includes:
15" Front Box Kit
15" Rear Box Kit
Cv Front Drive Shaft
Rear Drive Shaft Spacer
Front/ Rear Steel Braided Brake Lines

Basic 2WD SUV Kit Includes:
18" Front Box Kit
18" Rear Box Kit
Rear Drive Shaft Spacer
Front/ Rear Steel Braided Brake Lines

Basic 4WD SUV Kit Includes:
18" Front Box Kit
18" Rear Box Kit
Cv Front Drive Shaft
Rear Drive Shaft Spacer
Front/ Rear Steel Braided Brake Lines

Shocks Sold Separately.
Please see options below.

PART #	YEAR	TITLE	FOOTNOTES	LIFT SIZE	2WD / 4WD
15"/18" 2000-2006 CHEVY / GMC ESCALADE / DENALI / TAHOE / SUBURBAN / AVALANCHE / YUKON					
85602	1999-2006	TAHOE / SUBURBAN / AVALANCHE / YUKON 1500 BASIC KIT		19, 36, 39, 52	15" 2WD
85603	1999-2006	TAHOE / SUBURBAN / AVALANCHE / YUKON 1500 BASIC KIT *INCLUDES CV FRONT DRIVE SHAFT		19, 28, 39, 52	15" 4WD
85702	2000-2006	TAHOE / SUBURBAN / AVALANCHE / YUKON 1500 BASIC KIT		19, 36, 39, 52	18" 2WD
85703	2000-2006	TAHOE / SUBURBAN / AVALANCHE / YUKON 1500 BASIC KIT *INCLUDES CV FRONT DRIVE SHAFT		19, 28, 39, 52	18" 4WD
DOUBLE FRONT SHOCK UPGRADE					
85410	1999-2006	DOUBLE FRONT HOOPS W/ BALL JOINT UPPER A ARMS		27, 41	15"/18" 2WD / 4WD
85416	1999-2006	DOUBLE FRONT HOOPS W/ UNIBALL UPPER A ARMS		27, 40	15"/18" 2WD / 4WD
85440	1999-2006	DOUBLE FRONT HOOPS W/ UPPER A ARMS BRACKETS		27	15"/18" 2WD / 4WD
85441	1999-2006	BALL JOINT UPPER A ARMS		41	15"/18" 2WD / 4WD
85442	1999-2006	UNI BALL UPPER A ARMS		40, 41	15"/18" 2WD / 4WD
C2011-625R	1999-2006	FTS 2.0 REMOTE RESERVOIR 11" TRAVEL CHROME FINISH (DOUBLE FRONT SHOCK)		29, 30	15" 2WD / 4WD
B2011-625R	1999-2006	FTS 2.0 REMOTE RESERVOIR 11" TRAVEL BLACK FINISH (DOUBLE FRONT SHOCK)		29, 31	15" 2WD / 4WD
C2012-625R	1999-2006	FTS 2.0 REMOTE RESERVOIR 12" TRAVEL CHROME FINISH (DOUBLE FRONT SHOCK)		29, 30	18" 2WD / 4WD
B2012-625R	1999-2006	FTS 2.0 REMOTE RESERVOIR 12" TRAVEL BLACK FINISH (DOUBLE FRONT SHOCK)		29, 31	18" 2WD / 4WD
SINGLE FRONT SHOCK STOCK LOCATION					
C2016-875RS	1999-2006	FTS 2.0 REMOTE RESERVOIR 16" TRAVEL CHROME FINISH		29, 30	15"/18" 2WD / 4WD
B2016-875RS	1999-2006	FTS 2.0 REMOTE RESERVOIR 16" TRAVEL BLACK FINISH		29, 31	15"/18" 2WD / 4WD
SINGLE REAR SHOCK STOCK LOCATION					
C2016-875R	1999-2006	FTS 2.0 REMOTE RESERVOIR 16" TRAVEL CHROME FINISH (STOCK REAR LOCATION)		29, 30, 54	15"/18" 2WD / 4WD
B2016-875R	1999-2006	FTS 2.0 REMOTE RESERVOIR 16" TRAVEL BLACK FINISH (STOCK REAR LOCATION)		29, 31, 54	15"/18" 2WD / 4WD
BILLET SHOCK CLAMPS					
C2020	1999-2006	FTS 2.0 TO 2.0 BILLET SHOCK CLAMPS CHROME FINISH		38	15"/18" 2WD / 4WD
B2020	1999-2006	FTS 2.0 TO 2.0 BILLET SHOCK CLAMPS BLACK FINISH		38	15"/18" 2WD / 4WD
ACCESSORIES					
85622	1999-2006	FRONT / REAR STEEL BRAIDED BRAKE LINE KIT (SINGLE REAR)		79	15"/18" 2WD / 4WD
84843	1999-2006	HEAVY DUTY HEIMS JOINT STEERING KIT		19, 22, 23	15"/18" 2WD / 4WD
85246	1999-2006	DOUBLE FRONT STEERING STABILIZER KIT W/ BASIC HYDRAULIC STABILIZERS		56	15"/18" 2WD / 4WD
85451	1999-2006	IDLER ARM BRACE		18	15"/18" 2WD / 4WD
CVDL40	1999-2006	CV FRONT DRIVE SHAFT 40"		35	15"/18" 4WD
38303	1999-2006	2" TORSION KEYS		52	15"/18" 2WD / 4WD
3R	1999-2006	2" REAR DRIVE SHAFT SPACER 3R		59, 60	15"/18" 2WD / 4WD
1350	1999-2006	2" REAR DRIVE SHAFT SPACER 1350		59, 60	15"/18" 2WD / 4WD
85800	1999-2006	DIFFERENTIAL EAR REPLACEMENT BRACKET		27, 44	15"/18" 4WD

6.5" 2003 - 2010 HUMMER H2 / SUT

- 100% Bolt On kit that DOES NOT extend the track width
- Front differential is dropped a full amount to maintain proper CV axle angles
- Impact struts to distribute front suspension impact loads through frame
- Rear kit utilizes factory coils springs or airbag for stock ride
- Utilizes the factory front bump stops for superior ride quality
- Semi Gloss black powder-coat for a long lasting great look
- No cutting on front differential or factory bump stops
- Cross-member are constructed of 1/4" thick steel
- Lifetime Warranty against manufactures defects
- No exhaust modification required
- No wheel restrictions on 6.5" kit



Basic 6.5" kit includes:
 6.5" Front Box Kit
 6.5" Rear Box Kit
 Cv Front Drive Shaft

Basic 7" kit includes:
 7" Front Box Kit
 LH / RH Steering Knuckles
 7" Rear Box kit
 Cv Front Drive Shaft
 Shocks Sold Separately.
 Please see options below

6.5" Kit Max Recommended Tire Size 37" - 38" Max Recommended Wheel Width 10"
 7" Kit Max Recommended Tire Size 37" - 38" Max Recommended Wheel Width 10"
 7" Kit Required 17" or larger Wheel with no more than 5" Backspace

PART #	YEAR	TITLE	FOOTNOTES	LIFT SIZE	2WD / 4WD
6.5" 2003-2010 HUMMER H2					
85503	2003-2010	HUMMER H2 BASIC KIT W/ AIR RIDE *INCLUDES CV FRONT DRIVE SHAFT	4, 27, 37, 52	6.5"	4WD
85504	2003-2010	HUMMER H2 BASIC KIT W/ REAR COIL *INCLUDES CV FRONT DRIVE SHAFT	4, 27, 37, 52	6.5"	4WD
DOUBLE FRONT SHOCK UPGRADE					
85238	2003-2010	DOUBLE FRONT HOOPS W/ UNI BALL UPPER A ARMS	27, 40, 41	6.5"	4WD
85239	2003-2010	DOUBLE FRONT HOOPS W/ BALL JOINT UPPER A ARMS	27, 41	6.5"	4WD
85240	2003-2010	DOUBLE FRONT HOOPS W/ UPPER A ARMS BRACKETS	27	6.5"	4WD
85242	2003-2010	UNI BALL UPPER A ARMS	40, 41	6.5"	4WD
85241	2003-2010	BALL JOINT UPPER A ARMS	41	6.5"	4WD
C2085-625R	2003-2010	FTS 2.0 REMOTE RESERVOIR 8.5" TRAVEL CHROME FINISH (DOUBLE FRONT SHOCK)	29, 30	6.5"	4WD
B2085-625R	2003-2010	FTS 2.0 REMOTE RESERVOIR 8.5" TRAVEL BLACK FINISH (DOUBLE FRONT SHOCK)	29, 31	6.5"	4WD
SINGLE FRONT SHOCK STOCK LOCATION					
C2085-625RS	2003-2010	FTS 2.0 REMOTE RESERVOIR 8.5" TRAVEL CHROME FINISH (STOCK FRONT LOCATION)	29, 30	6.5"	4WD
B2085-625RS	2003-2010	FTS 2.0 REMOTE RESERVOIR 8.5" TRAVEL BLACK FINISH (STOCK FRONT LOCATION)	29, 31	6.5"	4WD
SINGLE REAR SHOCK STOCK LOCATION					
C2012-625R	2003-2010	FTS 2.0 REMOTE RESERVOIR 12" TRAVEL CHROME FINISH (SINGLE REAR SHOCK)	29, 30	6.5"	4WD
B2012-625R	2003-2010	FTS 2.0 REMOTE RESERVOIR 12" TRAVEL BLACK FINISH (SINGLE REAR SHOCK)	29, 31	6.5"	4WD
BILLET SHOCK CLAMPS					
C2020	2003-2010	FTS 2.0 TO 2.0 BILLET SHOCK CLAMPS CHROME FINISH	38	6.5"	4WD
B2020	2003-2010	FTS 2.0 TO 2.0 BILLET SHOCK CLAMPS BLACK FINISH	38	6.5"	4WD
ACCESSORIES					
85508	2003-2010	6.5" REAR HUMMER KIT (W/ REAR AIR RIDE)	27, 52	6.5"	4WD
85509	2003-2010	6.5" REAR HUMMER KIT (W/ REAR COIL)	27, 52	6.5"	4WD
85028	2003-2010	FRONT / REAR STEEL BRAIDED BRAKE LINE KIT (DUAL REAR)	79	6.5"	4WD
85243	2003-2010	HEAVY DUTY HEIMS JOINT STEERING	38	6.5"	4WD
85246	2003-2010	DOUBLE FRONT STEERING STABILIZER KIT W/ BASIC HYDRAULIC STABILIZERS	56	6.5"	4WD
85059	2003-2010	IDLER ARM BRACE H2	18	6.5"	4WD
85060	2003-2010	REAR LOWER TRAILING ARMS	69	6.5"	4WD
85061	2003-2010	REAR TUBULAR TRACK BAR	68	6.5"	4WD
85062	2003-2010	REAR HEIMS JOINT SWAY BAY ENDLINK KIT	27, 56	6.5"	4WD
CVDL36	2003-2010	CV FRONT DRIVE SHAFT 36"	35, 47	6.5"	4WD

HUMMER H2 6.5" BASIC KIT W/ AIR RIDE
 Part #85503



HUMMER H2 7" BASIC KIT W/ COILS
 Part # 85108

7" 2003 - 2010 HUMMER H2 / SUT

PART #	YEAR	TITLE	FOOTNOTES	LIFT SIZE	2WD / 4WD
7" 2003-2010 HUMMER H2					
85107	2003-2010	HUMMER H2 BASIC KIT W/ AIR RIDE *INCLUDES CV FRONT DRIVE SHAFT	4, 27, 37, 52	7"	4WD
85108	2003-2010	HUMMER H2 BASIC KIT W/ REAR COIL *INCLUDES CV FRONT DRIVE SHAFT	4, 27, 37, 52	7"	4WD
DOUBLE FRONT SHOCK UPGRADE					
85048	2003-2010	DOUBLE FRONT HOOPS W/ UNI BALL UPPER A ARMS	27, 40, 41	7"	4WD
85042	2003-2010	DOUBLE FRONT HOOPS W/ BALL JOINT UPPER A ARMS	27, 41	7"	4WD
85040	2003-2010	DOUBLE FRONT HOOPS W/ UPPER A ARMS BRACKETS	27	7"	4WD
85047	2003-2010	UNI BALL UPPER A ARMS	40, 41	7"	4WD
85041	2003-2010	BALL JOINT UPPER A ARMS	41	7"	4WD
C2065-625R	2003-2010	FTS 2.0 REMOTE RESERVOIR 6.5" TRAVEL CHROME FINISH (DOUBLE FRONT SHOCK)	29, 30	7"	4WD
B2065-625R	2003-2010	FTS 2.0 REMOTE RESERVOIR 6.5" TRAVEL BLACK FINISH (DOUBLE FRONT SHOCK)	29, 31	7"	4WD
SINGLE FRONT SHOCK STOCK LOCATION					
C2085-625RS	2003-2010	FTS 2.0 REMOTE RESERVOIR 8.5" TRAVEL CHROME FINISH (STOCK FRONT LOCATION)	29, 30	7"	4WD
B2085-625RS	2003-2010	FTS 2.0 REMOTE RESERVOIR 8.5" TRAVEL BLACK FINISH (STOCK FRONT LOCATION)	29, 31	7"	4WD
SINGLE REAR SHOCK STOCK LOCATION					
C2012-625R	2003-2010	FTS 2.0 REMOTE RESERVOIR 12" TRAVEL CHROME FINISH (SINGLE REAR SHOCK)	29, 30	7"	4WD
B2012-625R	2003-2010	FTS 2.0 REMOTE RESERVOIR 12" TRAVEL BLACK FINISH (SINGLE REAR SHOCK)	29, 31	7"	4WD
BILLET SHOCK CLAMPS					
C2020	2003-2010	FTS 2.0 TO 2.0 BILLET SHOCK CLAMPS CHROME FINISH	38	7"	4WD
B2020	2003-2010	FTS 2.0 TO 2.0 BILLET SHOCK CLAMPS BLACK FINISH	38	7"	4WD
ACCESSORIES					
85508	2003-2010	7" REAR HUMMER KIT (W/ REAR AIR RIDE)	27, 52	7"	4WD
85509	2003-2010	7" REAR HUMMER KIT (W/ REAR COIL)	27, 52	7"	4WD
85028	2003-2010	FRONT / REAR STEEL BRAIDED BRAKE LINE KIT (DUAL REAR)	79	7"	4WD
85044	2003-2010	HEAVY DUTY HEIMS JOINT STEERING W/ STEERING BAR	22, 38	7"	4WD
85043	2003-2010	HEAVY DUTY HEIMS JOINT STEERING	38	7"	4WD
85046	2003-2010	DOUBLE FRONT STEERING STABILIZER KIT W/ BASIC HYDRAULIC STABILIZERS	56	7"	4WD
85059	2003-2010	IDLER ARM BRACE H2	18	7"	4WD
85060	2003-2010	REAR LOWER TRAILING ARMS	69	7"	4WD
85061	2003-2010	REAR TUBULAR TRACK BAR	68	7"	4WD
85062	2003-2010	REAR HEIMS JOINT SWAY BAY ENDLINK KIT	27, 56	7"	4WD
CVDL36	2003-2010	CV FRONT DRIVE SHAFT 36"	35, 47	7"	4WD



9.5" 2003 - 2010 HUMMER H2 / SUT

9.5"
12"
HUMMER
H2 / SUT
2003-2010

100% Bolt On - A Arm Drop kit that DOES NOT extend the track width
Front differential is dropped a full amount to maintain proper CV axle angles
Impact struts to distribute front suspension impact loads through frame
Rear kit utilizes factory coils springs or airbag for stock ride
Utilizes the factory front bumper stops for superior ride quality
Semi Gloss black powder-coat for a long lasting great look
Basic kit includes Front and Rear steel braided brake lines
No cutting on front differential or factory bumper stop
Cross-member are constructed of 1/4" thick steel
Lifetime Warranty against manufactures defects
No exhaust modification required
No wheel restrictions



Basic 9.5" kit includes:
9.5" Front Box Kit
9.5" Rear Box Kit
Cv Front Drive Shaft
Front / Rear Steel Braided Brake Lines

Basic 12" kit includes:
12" Front Box Kit
12" Rear Box Kit
Cv Front Drive Shaft
Front / Rear Steel Braided Brake Lines

Shocks Sold Separately,
Please see options below

9.5" Kit Max Recommended Tire Size 40" Max Recommended Wheel Width 10"
12" Kit Max Recommended Tire Size 44" Max Recommended Wheel Width 12"

PART #	YEAR	TITLE	FOOTNOTES	LIFT SIZE	2WD / 4WD
9.5" 2003-2010 HUMMER H2					
85200	2003-2010	HUMMER H2 BASIC KIT W/ AIR RIDE *INCLUDES CV FRONT DRIVE SHAFT	4, 27, 37, 52	9.5"	4WD
85203	2003-2010	HUMMER H2 BASIC KIT W/ REAR COIL *INCLUDES CV FRONT DRIVE SHAFT	4, 27, 37, 52	9.5"	4WD
DOUBLE FRONT SHOCK UPGRADE					
85238	2003-2010	DOUBLE FRONT HOOPS W/ UNI BALL UPPER A ARMS	27, 40, 41	9.5"	4WD
85239	2003-2010	DOUBLE FRONT HOOPS W/ BALL JOINT UPPER A ARMS	27, 41	9.5"	4WD
85240	2003-2010	DOUBLE FRONT HOOPS W/ UPPER A ARMS BRACKETS	27	9.5"	4WD
85242	2003-2010	UNI BALL UPPER A ARMS	40, 41	9.5"	4WD
85241	2003-2010	BALL JOINT UPPER A ARMS	41	9.5"	4WD
C2010-625R	2003-2010	FTS 2.0 REMOTE RESERVOIR 10" TRAVEL CHROME FINISH (DOUBLE FRONT SHOCK)	29, 30	9.5"	4WD
B2010-625R	2003-2010	FTS 2.0 REMOTE RESERVOIR 10" TRAVEL BLACK FINISH (DOUBLE FRONT SHOCK)	29, 31	9.5"	4WD
SINGLE FRONT SHOCK STOCK LOCATION					
C2011-625RS	2003-2010	FTS 2.0 REMOTE RESERVOIR 11" TRAVEL CHROME FINISH (STOCK FRONT LOCATION)	29, 30	9.5"	4WD
B2011-625RS	2003-2010	FTS 2.0 REMOTE RESERVOIR 11" TRAVEL BLACK FINISH (STOCK FRONT LOCATION)	29, 31	9.5"	4WD
SINGLE REAR SHOCK STOCK LOCATION					
C2014-625R	2003-2010	FTS 2.0 REMOTE RESERVOIR 14" TRAVEL CHROME FINISH (SINGLE REAR SHOCK)	29, 30	9.5"	4WD
B2014-625R	2003-2010	FTS 2.0 REMOTE RESERVOIR 14" TRAVEL BLACK FINISH (SINGLE REAR SHOCK)	29, 31	9.5"	4WD
BILLET SHOCK CLAMPS					
C2020	2003-2010	FTS 2.0 TO 2.0 BILLET SHOCK CLAMPS CHROME FINISH	38	9.5"	4WD
B2020	2003-2010	FTS 2.0 TO 2.0 BILLET SHOCK CLAMPS BLACK FINISH	38	9.5"	4WD
ACCESSORIES					
85208	2003-2010	9.5" REAR HUMMER KIT (W/ REAR AIR RIDE)	27, 52	9.5"	4WD
85209	2003-2010	9.5" REAR HUMMER KIT (W/ REAR COIL)	27, 52	9.5"	4WD
85128	2003-2010	FRONT / REAR STEEL BRAIDED BRAKE LINE KIT (DUAL REAR)	79	9.5"	4WD
85243	2003-2010	HEAVY DUTY HEIMS JOINT STEERING	38	9.5"	4WD
85246	2003-2010	DOUBLE FRONT STEERING STABILIZER KIT W/ BASIC HYDRAULIC STABILIZERS	56	9.5"	4WD
85059	2003-2010	IDLER ARM BRACE H2	18	9.5"	4WD
85060	2003-2010	REAR LOWER TRAILING ARMS	69	9.5"	4WD
85061	2003-2010	REAR TUBULAR TRACK BAR	68	9.5"	4WD
85162	2003-2010	REAR HEIMS JOINT SWAY BAY ENDLINK KIT	27, 56	9.5"	4WD
CVDL37	2003-2010	CV FRONT DRIVE SHAFT 37"	35, 47	9.5"	4WD

HUMMER H2 9.5" BASIC KIT W/ AIR RIDE
Part #85200



HUMMER H2 12" BASIC KIT W/ AIR RIDE
Part # 85300

12" 2003 - 2010 HUMMER H2 / SUT



PART #	YEAR	TITLE	FOOTNOTES	LIFT SIZE	2WD / 4WD
12" 2003-2010 HUMMER H2					
85300	2003-2010	HUMMER H2 BASIC KIT W/ AIR RIDE *INCLUDES CV FRONT DRIVE SHAFT	4, 27, 37, 52	12"	4WD
85303	2003-2010	HUMMER H2 BASIC KIT W/ REAR COIL *INCLUDES CV FRONT DRIVE SHAFT	4, 27, 37, 52	12"	4WD
DOUBLE FRONT SHOCK UPGRADE					
85238	2003-2010	DOUBLE FRONT HOOPS W/ UNI BALL UPPER A ARMS	27, 40, 41	12"	4WD
85239	2003-2010	DOUBLE FRONT HOOPS W/ BALL JOINT UPPER A ARMS	27, 41	12"	4WD
85240	2003-2010	DOUBLE FRONT HOOPS W/ UPPER A ARMS BRACKETS	27, 00	12"	4WD
85242	2003-2010	UNI BALL UPPER A ARMS	40, 41	12"	4WD
85241	2003-2010	BALL JOINT UPPER A ARMS	41, 00	12"	4WD
C2011-625R	2003-2010	FTS 2.0 REMOTE RESERVOIR 11" TRAVEL CHROME FINISH (DOUBLE FRONT SHOCK)	29, 30	12"	4WD
B2011-625R	2003-2010	FTS 2.0 REMOTE RESERVOIR 11" TRAVEL BLACK FINISH (DOUBLE FRONT SHOCK)	29, 31	12"	4WD
FRONT SHOCK STOCK LOCATION					
C2011-625RS	2003-2010	FTS 2.0 REMOTE RESERVOIR 11" TRAVEL CHROME FINISH (STOCK FRONT LOCATION)	29, 30	12"	4WD
B2011-625RS	2003-2010	FTS 2.0 REMOTE RESERVOIR 11" TRAVEL BLACK FINISH (STOCK FRONT LOCATION)	29, 31	12"	4WD
SINGLE REAR SHOCK STOCK LOCATION					
C2014-625R	2003-2010	FTS 2.0 REMOTE RESERVOIR 14" TRAVEL CHROME FINISH (SINGLE REAR SHOCK)	29, 30	12"	4WD
B2014-625R	2003-2010	FTS 2.0 REMOTE RESERVOIR 14" TRAVEL BLACK FINISH (SINGLE REAR SHOCK)	29, 31	12"	4WD
BILLET SHOCK CLAMPS					
C2020	2003-2010	FTS 2.0 TO 2.0 BILLET SHOCK CLAMPS CHROME FINISH	38, 00	12"	4WD
B2020	2003-2010	FTS 2.0 TO 2.0 BILLET SHOCK CLAMPS BLACK FINISH	38, 00	12"	4WD
ACCESSORIES					
85308	2003-2010	12" REAR HUMMER KIT (W/ REAR AIR RIDE)	27, 52	12"	4WD
85309	2003-2010	12" REAR HUMMER KIT (W/ REAR COIL)	27, 52	12"	4WD
85128	2003-2010	FRONT / REAR STEEL BRAIDED BRAKE LINE KIT (DUAL REAR)	79, 00	12"	4WD
85243	2003-2010	HEAVY DUTY HEIMS JOINT STEERING	38, 00	12"	4WD
85246	2003-2010	DOUBLE FRONT STEERING STABILIZER KIT W/ BASIC HYDRAULIC STABILIZERS	56, 00	12"	4WD
85059	2003-2010	IDLER ARM BRACE H2	18, 00	12"	4WD
85060	2003-2010	REAR LOWER TRAILING ARMS	69, 00	12"	4WD
85061	2003-2010	REAR TUBULAR TRACK BAR	68, 00	12"	4WD
85262	2003-2010	REAR HEIMS JOINT SWAY BAY ENDLINK KIT	27, 56	12"	4WD
CVDL37	2003-2010	CV FRONT DRIVE SHAFT 37"	35, 47	12"	4WD
1350	2003-2010	2" REAR DRIVE SHAFT SHAFT SPACER 1350	59, 60	12"	4WD

6.5" 1988 - 1998 CHEVY / GMC SILVERADO / SIERRA 1500/2500

Complete drop down kit and 100% bolt on
Full drop kit with no wheel offset restrictions
Front differential dropped full 6.5" for flat C/V angles
No cutting of the differential ear
Extended steering couplers for better travel
Heavy duty semi gloss black powder for long life and great looks
Upgraded alignment cams with added travel for precise alignment
Rear lift blocks for easy installation and factory ride
Maintains factory control arm geometry for factory ride and alignment



Max Recommended Tire Size 35" Max Recommended Wheel Width 10"

Basic 4WD kit includes:
6.5" Front Box Kit
5.5" Rear Block Kit
Shocks Sold Separately
Please see options below

SILVERADO / SIERRA 1500 BASIC KIT
Part # 83101



PART #	YEAR	TITLE	FOOTNOTES	LIFT SIZE	2WD / 4WD
1988-1998 CHEVY / GMC 6.5" TRUCK					
83101	1988-1998	SILVERADO / SIERRA 1500 BASIC KIT 6LUG	4, 27, 52, 82	6.5"	4WD
82101	1988-1998	SILVERADO / SIERRA 2500/3500 BASIC KIT 8 LUG	4, 27, 52, 82	6.5"	4WD
DOUBLE FRONT SHOCK UPGRADE					
83238	1988-1998	1/2 TON DOUBLE FRONT HOOPS W/ UNI BALL UPPER A ARMS	27, 40, 41	6.5"	4WD
83239	1988-1998	1/2 TON DOUBLE FRONT HOOPS W/ BALL JOINT UPPER A ARMS	27, 41	6.5"	4WD
83240	1988-1998	1/2 TON DOUBLE FRONT HOOPS W/ UPPER A ARMS BRACKETS	27	6.5"	4WD
82240	1988-1998	3/4 TON DOUBLE FRONT HOOPS W/ UPPER A ARMS BRACKETS	27	6.5"	4WD
83242	1988-1998	1/2 TON UNI BALL UPPER A ARMS	40, 41	6.5"	4WD
83241	1988-1998	1/2 TON BALL JOINT UPPER A ARMS	41	6.5"	4WD
C2085-625R	1988-1998	FTS 2.0 REMOTE RESERVOIR 8.5" TRAVEL CHROME FINISH (DOUBLE FRONT SHOCK)	29, 30	6.5"	4WD
B2085-625R	1988-1998	FTS 2.0 REMOTE RESERVOIR 8.5" TRAVEL BLACK FINISH (DOUBLE FRONT SHOCK)	29, 31	6.5"	4WD
SINGLE FRONT SHOCK STOCK LOCATION					
C2085-625R	1988-1998	FTS 2.0 REMOTE RESERVOIR 8.5" TRAVEL CHROME FINISH (STOCK FRONT LOCATION)	29, 30	6.5"	4WD
B2085-625R	1988-1998	FTS 2.0 REMOTE RESERVOIR 8.5" TRAVEL BLACK FINISH (STOCK FRONT LOCATION)	29, 31	6.5"	4WD
SINGLE REAR SHOCK STOCK LOCATION					
C2012-625R	1988-1998	FTS 2.0 REMOTE RESERVOIR 12" TRAVEL CHROME FINISH (STOCK REAR LOCATION)	29, 30	6.5"	4WD
B2012-625R	1988-1998	FTS 2.0 REMOTE RESERVOIR 12" TRAVEL BLACK FINISH (STOCK REAR LOCATION)	29, 31	6.5"	4WD
DOUBLE REAR SHOCK BRACKET					
83449	1988-1998	DOUBLE REAR SHOCK BRACKET KIT	12, 18, 27	6.5"	4WD
C2085-625R	1988-1998	FTS 2.0 REMOTE RESERVOIR 8.5" TRAVEL CHROME FINISH (DOUBLE REAR SHOCK)	29, 30	6.5"	4WD
B2085-625R	1988-1998	FTS 2.0 REMOTE RESERVOIR 8.5" TRAVEL BLACK FINISH (DOUBLE REAR SHOCK)	29, 31	6.5"	4WD
BILLET SHOCK CLAMPS					
C2020	1988-1998	FTS 2.0 TO 2.0 BILLET SHOCK CLAMPS CHROME FINISH	38	6.5"	4WD
B2020	1988-1998	FTS 2.0 TO 2.0 BILLET SHOCK CLAMPS BLACK FINISH	38	6.5"	4WD
ACCESSORIES					
83022	1988-1998	FRONT / REAR STEEL BRAIDED BRAKE LINE KIT (SINGLE REAR)	79	6.5"	4WD
83843	1988-1998	HEIMS JOINT STEERING KIT	19, 22, 23	6.5"	4WD
85046	1988-1998	DOUBLE FRONT STEERING STABILIZER KIT	56	6.5"	4WD
12960	1988-1998	BOLT ON TRACTION BAR KIT 60" (SHORT BED)	27, 56, 58	6.5"	4WD
12968	1988-1998	BOLT ON TRACTION BAR KIT 68" (LONG BED)	27, 56, 58	6.5"	4WD
C7	1988-1998	7" REAR LEAF SPRINGS	55	6.5"	4WD
85250	1988-1998	REAR AIR BAG KIT (USE W/ FTS STOCK REAR SPRINGS)	27, 56	6.5"	4WD
CVDL38	1997-UP	CV FRONT DRIVE SHAFT 38"	35, 47	6.5"	4WD

TAHOE / SUBURBAN BASIC KIT
Part #83101

6.5" 1992 - 1998 TAHOE / SUBURBAN



BASIC SHOCKS

Front Shock Stock Location	124500
Rear Shock Stock Location	129500
Double Front Shock	120500
Double Rear Shock	124500

PART #	YEAR	TITLE	FOOTNOTES	LIFT SIZE	2WD / 4WD
1992-1998 CHEVY / GMC 6.5" TAHOE / SUBURBAN					
83101	1992-1998	1500 TAHOE 2DR / SUBURBAN BASIC KIT 6LUG	4, 27, 52, 82	6.5"	4WD
83102	1992-1998	1500 TAHOE 4DR BASIC KIT 6LUG	4, 27, 52, 82	6.5"	4WD
82101	1992-1998	2500 SUBURBAN BASIC KIT 8LUG	4, 27, 52, 82	6.5"	4WD
DOUBLE FRONT SHOCK UPGRADE					
83238	1992-1998	DOUBLE FRONT HOOPS W/ UNI BALL UPPER A ARMS	27, 40, 41	6.5"	4WD
83239	1992-1998	DOUBLE FRONT HOOPS W/ BALL JOINT UPPER A ARMS	27, 41	6.5"	4WD
83240	1992-1998	DOUBLE FRONT HOOPS W/ UPPER A ARMS BRACKETS	27	6.5"	4WD
82240	1992-1998	3/4 TON DOUBLE FRONT HOOPS W/ UPPER A ARMS BRACKETS	27	6.5"	4WD
83242	1992-1998	1/2 TON UNI BALL UPPER A ARMS	40, 41	6.5"	4WD
83241	1992-1998	1/2 TON BALL JOINT UPPER A ARMS	41	6.5"	4WD
C2065-625R	1992-1998	FTS 2.0 REMOTE RESERVOIR 6.5" TRAVEL CHROME FINISH (DOUBLE FRONT SHOCK)	29, 30	6.5"	4WD
B2065-625R	1992-1998	FTS 2.0 REMOTE RESERVOIR 6.5" TRAVEL BLACK FINISH (DOUBLE FRONT SHOCK)	29, 31	6.5"	4WD
SINGLE FRONT SHOCK STOCK LOCATION					
C2010-625R	1992-1998	FTS 2.0 REMOTE RESERVOIR 10" TRAVEL CHROME FINISH (STOCK FRONT LOCATION)	29, 30	6.5"	4WD
B2010-625R	1992-1998	FTS 2.0 REMOTE RESERVOIR 10" TRAVEL BLACK FINISH (STOCK FRONT LOCATION)	29, 31	6.5"	4WD
SINGLE REAR SHOCK STOCK LOCATION					
C2012-625R	1992-1998	FTS 2.0 REMOTE RESERVOIR 12" TRAVEL CHROME FINISH (STOCK REAR LOCATION)	29, 30	6.5"	4WD
B2012-625R	1992-1998	FTS 2.0 REMOTE RESERVOIR 12" TRAVEL BLACK FINISH (STOCK REAR LOCATION)	29, 31	6.5"	4WD
BILLET SHOCK CLAMPS					
C2020	1992-1998	FTS 2.0 TO 2.0 BILLET SHOCK CLAMPS CHROME FINISH	29, 30	6.5"	4WD
B2020	1992-1998	FTS 2.0 TO 2.0 BILLET SHOCK CLAMPS BLACK FINISH	29, 31	6.5"	4WD
ACCESSORIES					
83022	1992-1998	FRONT / REAR STEEL BRAIDED BRAKE LINE KIT (SINGLE REAR)	79	6.5"	4WD
83843	1992-1998	HEIMS JOINT STEERING KIT	19, 22, 23	6.5"	4WD
85246	1992-1998	DOUBLE FRONT STEERING STABILIZER KIT W/ BASIC HYDRAULIC STABILIZERS	56	6.5"	4WD
CVDL38	1997-UP	CV FRONT DRIVE SHAFT 38"	35, 47	6.5"	4WD

9.5" 1988 - 1998 CHEVY/GMC SILVERADO / SIERRA 1500/2500

9.5" IN
SILVERADO / SIERRA / TAHOE / SUBURBAN
1988-1998
CHEVY / GMC

Complete drop down kit and 100% bolt on
Full drop kit with no wheel offset restrictions
Front differential dropped full 9.5" for flat C/V angles
No cutting of the differential ear
Extended steering couplers for better travel
Impact struts to distribute suspension impact throughout the frame
Structural crossmembers constructed of 1/4" thick steel for superior strength
Upgraded alignment cams with added travel for precise alignment
Heavy duty semi gloss black powder for long life and great looks
Maintains factory control arm geometry for factory ride and alignment



Max Recommended Tire Size 37" Max Recommended Wheel Width 10"

Basic 4WD kit includes:

9.5" Front Box Kit
10" Rear Springs
Front / Rear Steel Braided Brake Lines

Shocks Sold Separately.
Please see options below

SILVERADO / SIERRA 1500 BASIC KIT
Part # 83201

PART #	YEAR	TITLE	FOOTNOTES	LIFT SIZE	2WD / 4WD
1988-1998 CHEVY / GMC 9.5" TRUCK					
83201	1988-1998	SILVERADO / SIERRA 1500 BASIC KIT 6 LUG	4, 27, 52, 82	9.5"	4WD
82201	1988-1998	SILVERADO / SIERRA 2500/3500 BASIC KIT 8 LUG	4, 27, 52, 82	9.5"	4WD
DOUBLE FRONT SHOCK UPGRADE					
83238	1988-1998	1/2 TON DOUBLE FRONT HOOPS W/ UNI BALL UPPER A ARMS	27, 40, 41	9.5"	4WD
83239	1988-1998	1/2 TON DOUBLE FRONT HOOPS W/ BALL JOINT UPPER A ARMS	27, 41	9.5"	4WD
83240	1988-1998	1/2 TON DOUBLE FRONT HOOPS W/ UPPER A ARMS BRACKETS	27	9.5"	4WD
82240	1988-1998	3/4 TON DOUBLE FRONT HOOPS W/ UPPER A ARMS BRACKETS	27	9.5"	4WD
83242	1988-1998	1/2 TON UNI BALL UPPER A ARMS	40, 41	9.5"	4WD
83241	1988-1998	1/2 TON BALL JOINT UPPER A ARMS	41	9.5"	4WD
C2085-625R	1988-1998	FTS 2.0 REMOTE RESERVOIR 8.5" TRAVEL CHROME FINISH (DOUBLE FRONT SHOCK)	29, 30	9.5"	4WD
B2085-625R	1988-1998	FTS 2.0 REMOTE RESERVOIR 8.5" TRAVEL BLACK FINISH (DOUBLE FRONT SHOCK)	29, 31	9.5"	4WD
SINGLE FRONT SHOCK STOCK LOCATION					
C2010-625R	1988-1998	FTS 2.0 REMOTE RESERVOIR 10" TRAVEL CHROME FINISH (STOCK FRONT LOCATION)	29, 30	9.5"	4WD
B2010-625R	1988-1998	FTS 2.0 REMOTE RESERVOIR 10" TRAVEL BLACK FINISH (STOCK FRONT LOCATION)	29, 31	9.5"	4WD
SINGLE REAR SHOCK STOCK LOCATION					
C2012-625R	1988-1998	FTS 2.0 REMOTE RESERVOIR 12" TRAVEL CHROME FINISH (STOCK REAR LOCATION)	29, 30	9.5"	4WD
B2012-625R	1988-1998	FTS 2.0 REMOTE RESERVOIR 12" TRAVEL BLACK FINISH (STOCK REAR LOCATION)	29, 31	9.5"	4WD
DOUBLE REAR SHOCK BRACKET					
83449	1988-1998	DOUBLE REAR SHOCK BRACKET KIT	12, 18, 27	9.5"	4WD
C2010-625R	1988-1998	FTS 2.0 REMOTE RESERVOIR 10" TRAVEL CHROME FINISH (DOUBLE REAR SHOCK)	29, 30	9.5"	4WD
B2010-625R	1988-1998	FTS 2.0 REMOTE RESERVOIR 10" TRAVEL BLACK FINISH (DOUBLE REAR SHOCK)	29, 31	9.5"	4WD
BILLET SHOCK CLAMPS					
C2020	1988-1998	FTS 2.0 TO 2.0 BILLET SHOCK CLAMPS CHROME FINISH	38	9.5"	4WD
B2020	1988-1998	FTS 2.0 TO 2.0 BILLET SHOCK CLAMPS BLACK FINISH	38	9.5"	4WD
ACCESSORIES					
83222	1988-1998	FRONT / REAR STEEL BRAIDED BRAKE LINE KIT (SINGLE REAR)	79	9.5"	4WD
83843	1988-1998	HEIMS JOINT STEERING KIT	19, 22, 23	9.5"	4WD
85246	1988-1998	DOUBLE FRONT STEERING STABILIZER KIT W/ BASIC HYDRAULIC STABILIZERS	56	9.5"	4WD
12963	1988-1998	BOLT ON TRACTION BAR KIT 63" (SHORT BED)	27, 56, 58	9.5"	4WD
12972	1988-1998	BOLT ON TRACTION BAR KIT 72" (LONG BED)	27, 56, 58	9.5"	4WD
85250	1988-1998	REAR AIR BAG KIT (USE W/ FTS 10" SPRINGS)	27, 56	9.5"	4WD
CVDL38	1997-UP	CV FRONT DRIVE SHAFT 38" (FITS 97 AND NEWER TRUCK/SUV)	35, 47	9.5"	4WD
C10A	1988-1998	10" REAR LEAF SPRINGS	55	9.5"	4WD
3R	1988-1998	1/2 TON 2" REAR DRIVE SHAFT SPACER W/ 3R U JOINT	60	9.5"	4WD
1350	1988-1998	1/2 TON 2" REAR DRIVE SHAFT SPACER W/ 1350 U JOINT	60	9.5"	4WD



TAHOE / SUBURBAN BASIC KIT
Part # 83202

9.5" 1992 - 1998 TAHOE / SUBURBAN



PART #	YEAR	TITLE	FOOTNOTES	LIFT SIZE	2WD / 4WD
1992-1998 CHEVY / GMC 9.5" TAHOE / SUBURBAN					
83203	1992-1998	1500 TAHOE 2DR / SUBURBAN 6LUG BASIC KIT	4, 27, 52, 82	9.5"	4WD
83202	1992-1998	1500 TAHOE 4DR 6LUG BASIC KIT	4, 27, 52, 82	9.5"	4WD
83206	1992-1998	2500 SUBURBAN BASIC KIT 8 LUG BASIC KIT	4, 27, 52, 82	9.5"	4WD
DOUBLE FRONT SHOCK UPGRADE					
83238	1992-1998	1/2 TON DOUBLE FRONT HOOPS W/ UNI BALL UPPER A ARMS	27, 40, 41	9.5"	4WD
83239	1992-1998	1/2 TON DOUBLE FRONT HOOPS W/ BALL JOINT UPPER A ARMS	27, 41	9.5"	4WD
83240	1992-1998	1/2 TON DOUBLE FRONT HOOPS W/ UPPER A ARMS BRACKETS	27	9.5"	4WD
82240	1992-1998	3/4 TON DOUBLE FRONT HOOPS W/ UPPER A ARMS BRACKETS	27	9.5"	4WD
83242	1992-1998	UNI BALL UPPER A ARMS	40, 41	9.5"	4WD
83241	1992-1998	BALL JOINT UPPER A ARMS	41	9.5"	4WD
C2085-625R	1992-1998	FTS 2.0 REMOTE RESERVOIR 8.5" TRAVEL CHROME FINISH (DOUBLE FRONT SHOCK)	29, 30	9.5"	4WD
B2085-625R	1992-1998	FTS 2.0 REMOTE RESERVOIR 8.5" TRAVEL BLACK FINISH (DOUBLE FRONT SHOCK)	29, 31	9.5"	4WD
SINGLE FRONT SHOCK STOCK LOCATION					
C2010-625R	1992-1998	FTS 2.0 REMOTE RESERVOIR 10" TRAVEL CHROME FINISH (STOCK FRONT LOCATION)	29, 30	9.5"	4WD
B2010-625R	1992-1998	FTS 2.0 REMOTE RESERVOIR 10" TRAVEL BLACK FINISH (STOCK FRONT LOCATION)	29, 31	9.5"	4WD
SINGLE REAR SHOCK STOCK LOCATION					
C2012-625R	1992-1998	FTS 2.0 REMOTE RESERVOIR 12" TRAVEL CHROME FINISH (STOCK REAR LOCATION)	29, 30	9.5"	4WD
B2012-625R	1992-1998	FTS 2.0 REMOTE RESERVOIR 12" TRAVEL BLACK FINISH (STOCK REAR LOCATION)	29, 31	9.5"	4WD
BILLET SHOCK CLAMPS					
C2020	1992-1998	FTS 2.0 TO 2.0 BILLET SHOCK CLAMPS CHROME FINISH	38	9.5"	4WD
B2020	1992-1998	FTS 2.0 BILLET SHOCK CLAMPS BLACK FINISH	38	9.5"	4WD
ACCESSORIES					
83222	1992-1998	FRONT / REAR STEEL BRAIDED BRAKE LINE KIT (SINGLE REAR)	79	9.5"	4WD
83843	1992-1998	HEIMS JOINT STEERING KIT	19, 22, 23	9.5"	4WD
85246	1992-1998	DOUBLE FRONT STEERING STABILIZER KIT W/ BASIC HYDRAULIC STABILIZERS	56	9.5"	4WD
T10	1992-1998	10" REAR LEAF SPRINGS	55	9.5"	4WD
510	1992-1998	10" REAR LEAF SPRINGS	55	9.5"	4WD
CVDL38	1997-UP	CV FRONT DRIVE SHAFT 38" (FITS 97 AND NEWER TRUCK/SUV)	35, 47	9.5"	4WD
3R	1992-1998	1/2 TON 2" REAR DRIVE SHAFT SPACER W/ 3R U JOINT	60	9.5"	4WD

BASIC SHOCKS	
Front Shock Stock Location	126500
Rear Shock Stock Location	132000
Double Front Shock	122500
Double Rear Shock	126500

12" 1988-1998 CHEVY / GMC SILVERADO / SIERRA 1500/2500

Complete drop down kit and 100% bolt on
Full drop kit with no wheel offset restrictions
Front differential dropped full 12" for flat C/V angles
No cutting of the differential ear
Extended steering couplers for better travel
Impact struts to distribute suspension impact throughout the frame
Structural crossmembers constructed of 1/4" thick steel for superior strength
Upgraded alignment cams with added travel for precise alignment
Heavy duty semi gloss black powder for long life and great looks
Maintains factory control arm geometry for factory ride and alignment
Max Recommended Tire Size 39" Max Recommended Wheel Width 12"



PART #	YEAR	TITLE	FOOTNOTES	LIFT SIZE	2WD / 4WD
1988-1998 CHEVY / GMC 12" TRUCK					
83301	1988-1998	SILVERADO / SIERRA 1500 BASIC KIT	4, 27, 52, 82	12"	4WD
82301	1988-1998	SILVERADO / SIERRA 2500/3500 BASIC KIT	4, 27, 52, 82	12"	4WD
DOUBLE FRONT SHOCK UPGRADE					
83238	1988-1998	1/2 TON DOUBLE FRONT HOOPS W/ UNI BALL UPPER A ARMS	27, 40, 41	12"	4WD
83239	1988-1998	1/2 TON DOUBLE FRONT HOOPS W/ BALL JOINT UPPER A ARMS	27, 41	12"	4WD
83240	1988-1998	1/2 TON DOUBLE FRONT HOOPS W/ UPPER A ARMS BRACKETS	27	12"	4WD
82240	1988-1998	3/4 TON DOUBLE FRONT HOOPS W/ UPPER A ARMS BRACKETS	27	12"	4WD
83242	1988-1998	1/2 TON UNI BALL UPPER A ARMS	40, 41	12"	4WD
83241	1988-1998	1/2 TON BALL JOINT UPPER A ARMS	41	12"	4WD
C2010-625R	1988-1998	FTS 2.0 REMOTE RESERVOIR 10" TRAVEL CHROME FINISH (DOUBLE FRONT SHOCK)	29, 30	12"	4WD
B2010-625R	1988-1998	FTS 2.0 REMOTE RESERVOIR 10" TRAVEL BLACK FINISH (DOUBLE FRONT SHOCK)	29, 31	12"	4WD
SINGLE FRONT SHOCK STOCK LOCATION					
C2011-625R	1988-1998	FTS 2.0 REMOTE RESERVOIR 11" TRAVEL CHROME FINISH (STOCK FRONT LOCATION)	29, 30	12"	4WD
B2011-625R	1988-1998	FTS 2.0 REMOTE RESERVOIR 11" TRAVEL BLACK FINISH (STOCK FRONT LOCATION)	29, 31	12"	4WD
SINGLE REAR SHOCK STOCK LOCATION					
C2014-625R	1988-1998	FTS 2.0 REMOTE RESERVOIR 14" TRAVEL CHROME FINISH (STOCK REAR LOCATION)	29, 30	12"	4WD
B2014-625R	1988-1998	FTS 2.0 REMOTE RESERVOIR 14" TRAVEL BLACK FINISH (STOCK REAR LOCATION)	29, 31	12"	4WD
DOUBLE REAR SHOCK BRACKET					
83449	1988-1998	DOUBLE REAR SHOCK BRACKET KIT	12, 18, 27	12"	4WD
C2010-625R	1988-1998	FTS 2.0 REMOTE RESERVOIR 10" TRAVEL CHROME FINISH (DOUBLE REAR SHOCK)	29, 30	12"	4WD
B2010-625R	1988-1998	FTS 2.0 REMOTE RESERVOIR 10" TRAVEL BLACK FINISH (DOUBLE REAR SHOCK)	29, 31	12"	4WD
BILLET SHOCK CLAMPS					
C2020	1988-1998	FTS 2.0 TO 2.0 BILLET SHOCK CLAMPS CHROME FINISH	38	12"	4WD
B2020	1988-1998	FTS 2.0 TO 2.0 BILLET SHOCK CLAMPS BLACK FINISH	38	12"	4WD
ACCESSORIES					
83222	1988-1998	FRONT / REAR STEEL BRAIDED BRAKE LINE KIT (SINGLE REAR)	79	12"	4WD
83843	1988-1998	HEIMS JOINT STEERING KIT	19, 22, 23	12"	4WD
85246	1988-1998	DOUBLE FRONT STEERING STABILIZER KIT W/ BASIC HYDRAULIC STABILIZERS	56	12"	4WD
12963	1988-1998	BOLT ON TRACTION BAR KIT 63" (SHORT BED)	27, 56, 58	12"	4WD
12972	1988-1998	BOLT ON TRACTION BAR KIT 72" (LONG BED)	27, 56, 58	12"	4WD
85250	1988-1998	REAR AIR BAG KIT (USE W/ FTS 12" SPRINGS)	27, 56	12"	4WD
CVDL38	1997-UP	CV FRONT DRIVE SHAFT 38" (FITS 97 AND NEWER TRUCK/SUV)	35, 47	12"	4WD
C12A	1988-1998	12" REAR LEAF SPRINGS	55	12"	4WD
3R	1988-1998	1/2 TON 2" REAR DRIVE SHAFT SPACER W/ 3R U JOINT	60	12"	4WD
1350	1988-1998	1/2 TON 2" REAR DRIVE SHAFT SPACER W/ 1350 U JOINT	60	12"	4WD

Basic 4WD kit includes:
12" Front Box Kit
12" Rear Springs
Rear Drive Shaft Spacer
Front / Rear Steel Braided Brake Lines
Shocks Sold Separately.
Please see options below

SILVERADO / SIERRA 1500 BASIC KIT
Part # 83301



TAHOE / SUBURBAN BASIC KIT
Part #83302

12" 1992-1998 TAHOE / SUBURBAN

PART #	YEAR	TITLE	FOOTNOTES	LIFT SIZE	2WD / 4WD
1992-1998 CHEVY / GMC 12" TAHOE / SUBURBAN					
83303	1992-1998	TAHOE 2DR / SUBURBAN 6 LUG BASIC KIT	4, 27, 52, 82	12"	4WD
83302	1992-1998	TAHOE 4DR 1500 6 LUG BASIC KIT	4, 27, 52, 82	12"	4WD
83306	1992-1998	2500 SUBURBAN BASIC KIT 8 LUG BASIC KIT	4, 27, 52, 82	12"	4WD
DOUBLE FRONT SHOCK UPGRADE					
83238	1992-1998	1/2 TON DOUBLE FRONT HOOPS W/ UNI BALL UPPER A ARMS	27, 40, 41	12"	4WD
83239	1992-1998	1/2 TON DOUBLE FRONT HOOPS W/ BALL JOINT UPPER A ARMS	27, 41	12"	4WD
83240	1992-1998	1/2 TON DOUBLE FRONT HOOPS W/ UPPER A ARMS BRACKETS	27	12"	4WD
82240	1992-1998	3/4 TON DOUBLE FRONT HOOPS W/ UPPER A ARMS BRACKETS	27	12"	4WD
83242	1992-1998	1/2 TON UNI BALL UPPER A ARMS	40, 41	12"	4WD
83241	1992-1998	1/2 TON BALL JOINT UPPER A ARMS	41	12"	4WD
C2010-625R	1992-1998	FTS 2.0 REMOTE RESERVOIR 10" TRAVEL CHROME FINISH (DOUBLE FRONT SHOCK)	29, 30	12"	4WD
C2010-625R	1992-1998	FTS 2.0 REMOTE RESERVOIR 10" TRAVEL BLACK FINISH (DOUBLE FRONT SHOCK)	29, 31	12"	4WD
SINGLE FRONT SHOCK STOCK LOCATION					
C2011-625R	1992-1998	FTS 2.0 REMOTE RESERVOIR 11" TRAVEL CHROME FINISH (STOCK FRONT LOCATION)	29, 30	12"	4WD
B2011-625R	1992-1998	FTS 2.0 REMOTE RESERVOIR 11" TRAVEL BLACK FINISH (STOCK FRONT LOCATION)	29, 31	12"	4WD
SINGLE REAR SHOCK STOCK LOCATION					
C2014-625R	1992-1998	FTS 2.0 REMOTE RESERVOIR 14" TRAVEL CHROME FINISH (SINGLE REAR SHOCK)	29, 30	12"	4WD
B2014-625R	1992-1998	FTS 2.0 REMOTE RESERVOIR 14" TRAVEL BLACK FINISH (SINGLE REAR SHOCK)	29, 31	12"	4WD
BILLET SHOCK CLAMPS					
C2020	1992-1998	FTS 2.0 TO 2.0 BILLET SHOCK CLAMPS CHROME FINISH	38	12"	4WD
B2020	1992-1998	FTS 2.0 TO 2.0 BILLET SHOCK CLAMPS BLACK FINISH	38	12"	4WD
ACCESSORIES					
83222	1992-1998	FRONT / REAR STEEL BRAIDED BRAKE LINE KIT (SINGLE REAR)	79	12"	4WD
83843	1992-1998	HEIMS JOINT STEERING KIT	19, 22, 23	12"	4WD
85246	1992-1998	DOUBLE FRONT STEERING STABILIZER KIT W/ BASIC HYDRAULIC STABILIZERS	56	12"	4WD
CVDL38	1997 UP	CV FRONT DRIVE SHAFT 38" (FITS 97 AND NEWER TRUCK/SUV)	35, 47	12"	4WD
T12	1992-1998	12" REAR LEAF SPRING	55	12"	4WD
S12	1992-1998	12" REAR LEAF SPRING	55	12"	4WD
3R	1992-1998	1/2 TON 2" REAR DRIVE SHAFT SPACER W/ 3R U JOINT	60	12"	4WD
1350	1992-1998	1/2 TON 2" REAR DRIVE SHAFT SPACER W/ 1350 U JOINT	60	12"	4WD



BASIC SHOCKS

Front Shock Stock Location	129500
Rear Shock Stock Location	132000
Double Front Shock	126500
Double Rear Shock	129500

15" 1988 - 1998 CHEVY / GMC SILVERADO / SIERRA 1500/2500

15" IN CHEVY / GMC SILVERADO / SIERRA / TAHOE / SUBURBAN 1988-1998

Complete drop down kit and 100% bolt on
 Full drop kit with no wheel offset restrictions
 Front differential dropped full 15" for flat C/V angles
 No cutting of the differential ear
 Extended steering couplers for better travel
 Impact struts to distribute suspension impact throughout the frame
 Structural crossmembers constructed of 1/4" thick steel for superior strength
 Upgraded alignment cams with added travel for precise alignment
 Heavy duty semi gloss black powder for long life and great looks
 Maintains factory control arm geometry for factory ride and alignment
 Max Recommended Tire Size 42" Max Recommended Wheel Width 12"



Basic 4WD kit includes:
 15" Front Box Kit
 12" Rear Springs & 3" Rear Block Kit
 Rear Drive Shaft Spacer
 Front / Rear Steel Braided Brake Lines
 Shocks Sold Separately
 Please see options below

PART #	YEAR	TITLE	FOOTNOTES	LIFT SIZE	2WD / 4WD
1988-1998 CHEVY / GMC 15" TRUCK 1500 / 2500 / 3500					
83401	1988-1998	SILVERADO / SIERRA 1500 BASIC KIT	4, 27, 52, 82	15"	4WD
82401	1988-1998	SILVERADO / SIERRA 2500 / 3500 BASIC KIT	4, 27, 52, 82	15"	4WD
DOUBLE FRONT SHOCK UPGRADE					
83238	1988-1998	1/2 TON DOUBLE FRONT HOOPS W/ UNI BALL UPPER A ARMS	27, 40, 41	15"	4WD
83239	1988-1998	1/2 TON DOUBLE FRONT HOOPS W/ BALL JOINT UPPER A ARMS	27, 41	15"	4WD
83240	1988-1998	1/2 TON DOUBLE FRONT HOOPS W/ UPPER A ARMS BRACKETS	27	15"	4WD
82240	1988-1998	3/4 TON DOUBLE FRONT HOOPS W/ UPPER A ARMS BRACKETS	27	15"	4WD
83242	1988-1998	1/2 TON UNI BALL UPPER A ARMS	40, 41	15"	4WD
83241	1988-1998	1/2 TON BALL JOINT UPPER A ARMS	41	15"	4WD
C2011-625R	1988-1998	FTS 2.0 REMOTE RESERVOIR 11" TRAVEL CHROME FINISH (DOUBLE FRONT SHOCK)	29, 30	15"	4WD
B2011-625R	1988-1998	FTS 2.0 REMOTE RESERVOIR 11" TRAVEL BLACK FINISH (DOUBLE FRONT SHOCK)	29, 31	15"	4WD
SINGLE FRONT SHOCK STOCK LOCATION					
C2012-625R	1988-1998	FTS 2.0 REMOTE RESERVOIR 12" TRAVEL CHROME FINISH (SINGLE REAR SHOCK)	29, 30	15"	4WD
B2012-625R	1988-1998	FTS 2.0 REMOTE RESERVOIR 12" TRAVEL BLACK FINISH (SINGLE REAR SHOCK)	29, 31	15"	4WD
SINGLE REAR SHOCK STOCK LOCATION					
C2016-875R	1992-1998	FTS 2.0 REMOTE RESERVOIR 16" TRAVEL CHROME FINISH (SINGLE REAR SHOCK)	29, 30	15"	4WD
B2016-875R	1992-1998	FTS 2.0 REMOTE RESERVOIR 16" TRAVEL BLACK FINISH (SINGLE REAR SHOCK)	29, 31	15"	4WD
DOUBLE REAR SHOCK BRACKET					
83449	1988-1998	DOUBLE REAR SHOCK BRACKET KIT	12, 18, 27	15"	4WD
C20	1988-1998	FTS 2.0 REMOTE RESERVOIR 8.5" TRAVEL CHROME FINISH	29, 30	15"	4WD
B20	1988-1998	FTS 2.0 REMOTE RESERVOIR 8.5" TRAVEL BLACK FINISH	29, 31	15"	4WD
BILLET SHOCK CLAMPS					
C2020	1988-1998	FTS 2.0 TO 2.0 BILLET SHOCK CLAMPS CHROME FINISH	38	15"	4WD
B2020	1988-1998	FTS 2.0 TO 2.0 BILLET SHOCK CLAMPS BLACK FINISH	38	15"	4WD
ACCESSORIES					
83222	1988-1998	FRONT / REAR STEEL BRAIDED BRAKE LINE KIT (SINGLE REAR)	79	15"	4WD
83843	1988-1998	HEIMS JOINT STEERING KIT	19, 22, 23	15"	4WD
85246	1988-1998	DOUBLE FRONT STEERING STABILIZER KIT W/ BASIC HYDRAULIC STABILIZERS	56	15"	4WD
12968	1988-1998	BOLT ON TRACTION BAR KIT 68" (SHORT BED)	27, 56, 58	15"	4WD
12978	1988-1998	BOLT ON TRACTION BAR KIT 78" (LONG BED)	27, 56, 58	15"	4WD
85250	1988-1998	REAR AIR BAG KIT (USE W/ FTS 12" SPRINGS)	27, 56	15"	4WD
C12A	1988-1998	12" REAR LEAF SPRINGS		15"	4WD
CVDL40	1997-UP	CV FRONT DRIVE SHAFT 40" (FITS 97 AND NEWER TRUCK/SUV)	35, 47	15"	4WD
3R	1988-1998	1/2 TON 2" REAR DRIVE SHAFT SPACER W/ 3R U JOINT	60	15"	4WD
1350	1988-1998	1/2 TON 2" REAR DRIVE SHAFT SPACER W/ 1350 U JOINT	60	15"	4WD

SILVERADO / SIERRA 1500 BASIC KIT
 Part # 83401



Part # 12968

TAHOE / SUBURBAN BASIC KIT
 Part # 83402

15" 1992 - 1998 TAHOE / SUBURBAN

PART #	YEAR	TITLE	FOOTNOTES	LIFT SIZE	2WD / 4WD
1992-1998 CHEVY / GMC 15" TAHOE / SUBURBAN 1500/2500					
83402	1992-1998	TAHOE 2DR / SUBURBAN 1500 BASIC KIT	4, 27, 52, 82	15"	4WD
83403	1992-1998	TAHOE 4DR 1500 BASIC KIT	4, 27, 52, 82	15"	4WD
82401	1992-1998	SUBURBAN 2500 BASIC KIT	4, 27, 52, 82	15"	4WD
DOUBLE FRONT SHOCK UPGRADE					
83238	1992-1998	1/2 TON DOUBLE FRONT HOOPS W/ UNI BALL UPPER A ARMS	27, 40, 41	15"	4WD
83239	1992-1998	1/2 TON DOUBLE FRONT HOOPS W/ BALL JOINT UPPER A ARMS	27, 41	15"	4WD
83240	1992-1998	1/2 TON DOUBLE FRONT HOOPS W/ UPPER A ARMS BRACKETS	27	15"	4WD
82240	1992-1998	3/4 TON DOUBLE FRONT HOOPS W/ UPPER A ARMS BRACKETS	27	15"	4WD
83242	1992-1998	1/2 TON UNI BALL UPPER A ARMS	40, 41	15"	4WD
83241	1992-1998	1/2 TON BALL JOINT UPPER A ARMS	41	15"	4WD
C2011-625R	1992-1998	FTS 2.0 REMOTE RESERVOIR 11" TRAVEL CHROME FINISH (DOUBLE FRONT SHOCK)	29, 30	15"	4WD
B2011-625R	1992-1998	FTS 2.0 REMOTE RESERVOIR 11" TRAVEL BLACK FINISH (DOUBLE FRONT SHOCK)	29, 31	15"	4WD
SINGLE FRONT SHOCK STOCK LOCATION					
C2014-625R	1992-1998	FTS 2.0 REMOTE RESERVOIR 14" TRAVEL CHROME FINISH (SINGLE REAR SHOCK)	29, 30	15"	4WD
B2014-625R	1992-1998	FTS 2.0 REMOTE RESERVOIR 14" TRAVEL BLACK FINISH (SINGLE REAR SHOCK)	29, 31	15"	4WD
SINGLE REAR SHOCK STOCK LOCATION					
C2016-875R	1992-1998	FTS 2.0 REMOTE RESERVOIR 16" TRAVEL CHROME FINISH (SINGLE REAR SHOCK)	29, 30	15"	4WD
B2016-875R	1992-1998	FTS 2.0 REMOTE RESERVOIR 16" TRAVEL BLACK FINISH (SINGLE REAR SHOCK)	29, 31	15"	4WD
BILLET SHOCK CLAMPS					
C2020	1992-1998	FTS 2.0 TO 2.0 BILLET SHOCK CLAMPS CHROME FINISH	38	15"	4WD
B2020	1992-1998	FTS 2.0 TO 2.0 BILLET SHOCK CLAMPS BLACK FINISH	38	15"	4WD
ACCESSORIES					
83622	1992-1998	FRONT / REAR STEEL BRAIDED BRAKE LINE KIT (SINGLE REAR)	79	15"	4WD
83843	1992-1998	HEIMS JOINT STEERING KIT	19, 22, 23	15"	4WD
85246	1992-1998	DOUBLE FRONT STEERING STABILIZER KIT W/ BASIC HYDRAULIC STABILIZERS	56	15"	4WD
12968	1992-1998	BOLT ON TRACTION BAR KIT 68" (SHORT BED)	27, 56, 58	15"	4WD
CVDL40	1992-1998	CV FRONT DRIVE SHAFT 40" (FITS 97 AND NEWER TRUCK/SUV)	35, 47	15"	4WD
T12	1992-1998	12" REAR LEAF SPRINGS		15"	4WD
S12	1992-1998	12" REAR LEAF SPRINGS		15"	4WD
3R	1992-1998	1/2 TON 2" REAR DRIVE SHAFT SPACER W/ 3R U JOINT	60	15"	4WD
1350	1992-1998	1/2 TON 2" REAR DRIVE SHAFT SPACER W/ 1350 U JOINT	60	15"	4WD



Part # 85246

6" 2003 - 2012 DODGE RAM 2500 / 3500

Heavy duty long arm construction for superior ride quality and travel
 Lower Arms constructed of 1.75" DOM tubing w/ urethane bushing on both ends
 Extended Links are over twice the length of the factory arms
 Easy to install long arm brackets utilize factory transmission crossmember
 Moves front axle forward for better fender clearance
 Matched pitman arm drop and track bar bracket to reduce bumpsteer
 Full 6" or 8" Coil with factory like ride
 New transmission mount to alleviate driveline vibration
 Rear lift is accomplished w/ offset rear lift blocks keep rear axle centered
 Heavy duty semi gloss black powder for long life and great looks
 8" Kit includes Transfer case reclocking ring to alleviate driveline vibration
 Kits are available with replacement Coil Springs or upgradable Coilover conversion



Basic 6" kit includes:
 6" Front Box Kit
 6" Coil Springs
 3" Rear Block Kit

Basic 8" kit includes:
 8" Front Box Kit
 8" Coil Springs
 5" Rear Block Kit
 Front Drive Shaft Spacer
 Transfercase Reclocking Ring

Shocks Sold Separately.
 Please see options below

6" Kit Max Recommended Tire Size 35" Max Recommended Wheel Width 10"
 8" Kit Max Recommended Tire Size 37" Max Recommended Wheel Width 10"

PART #	YEAR	TITLE	FOOTNOTES	LIFT SIZE	2WD / 4WD
6" DODGE 2500/3500 SHORT ARM KIT					
63022	2009-2012	2009-2012 6" SHORT ARM DODGE 2500/3500 4WD GAS BASIC KIT	27, 56	6"	4WD
63023	2009-2012	2009-2012 6" SHORT ARM DODGE 2500/3500 4WD DIESEL BASIC KIT	27, 56	6"	4WD
63024	2003-2008	2003-2008 6" SHORT ARM DODGE 2500/3500 4WD GAS BASIC KIT	27, 56	6"	4WD
63025	2003-2008	2003-2008 6" SHORT ARM DODGE 2500/3500 4WD DIESEL BASIC KIT	27, 56	6"	4WD
6" DODGE 2500/3500 LONG ARM KIT					
63010	2009-2012	2009-2012 6" LONG ARM DODGE 2500/3500 4WD GAS BASIC KIT	27, 56	6"	4WD
63020	2009-2012	2009-2012 6" LONG ARM DODGE 2500/3500 4WD DIESEL BASIC KIT	27, 56	6"	4WD
63030	2003-2008	2003-2008 6" LONG ARM DODGE 2500/3500 4WD GAS BASIC KIT	27, 56	6"	4WD
63040	2003-2008	2003-2008 6" LONG ARM DODGE 2500/3500 4WD DIESEL BASIC KIT	27, 56	6"	4WD
DOUBLE FRONT SHOCK (1 INSIDE COIL 1 OUTSIDE COIL MOUNTED ON SHOCK HOOP)					
63900	2003-2012	DOUBLE FRONT SHOCK HOOPS (WORKS ONLY WITH LONG ARM KIT)	27, 39	6"	4WD
63901	2003-2012	DOUBLE FRONT SHOCK HOOPS (WORKS ONLY WITH SHORT ARM KIT)	27, 39	6"	4WD
C2010-625R	2003-2012	FTS 2.0 REMOTE RESERVOIR 11" TRAVEL CHROME FINISH (INSIDE COIL)	29, 30	6"	4WD
B2010-625R	2003-2012	FTS 2.0 REMOTE RESERVOIR 11" TRAVEL BLACK FINISH (INSIDE COIL)	29, 31	6"	4WD
C2085-625R	2003-2012	FTS 2.0 REMOTE RESERVOIR 8.5" TRAVEL CHROME FINISH (MOUNTS ON HOOP)	29, 30	6"	4WD
B2085-625R	2003-2012	FTS 2.0 REMOTE RESERVOIR 8.5" TRAVEL BLACK FINISH (MOUNTS ON HOOP)	29, 31	6"	4WD
SINGLE FRONT SHOCK INSIDE COIL					
C2011-625ES	2003-2012	FTS 2.0 EMULSION 11" TRAVEL CHROME FINISH (INSIDE COIL STOCK LOCATION)	29, 30	6"	4WD
B2011-625ES	2003-2012	FTS 2.0 EMULSION 11" TRAVEL BLACK FINISH (INSIDE COIL STOCK LOCATION)	29, 31	6"	4WD
SINGLE REAR SHOCK STOCK LOCATION					
C2012-625R	2003-2012	FTS 2.0 REMOTE RESERVOIR 12" TRAVEL CHROME FINISH (STOCK REAR LOCATION)	29, 30	6"	4WD
B2012-625R	2003-2012	FTS 2.0 REMOTE RESERVOIR 12" TRAVEL BLACK FINISH (STOCK REAR LOCATION)	29, 31	6"	4WD

6" DODGE RAM 2500 / 3500
 LONG ARM KIT Part # 63020



6" DODGE RAM 2500 / 3500
 SHORT ARM KIT Part # 63020



8" 2003 - 2012 DODGE RAM 2500 / 3500

8" DODGE RAM 2500 / 3500
 LONG ARM KIT Part # 63120



Part # 63900



Part # 63802

Part # 64000-9



Part # 25963



PART #	YEAR	TITLE	FOOTNOTES	LIFT SIZE	2WD / 4WD
8" DODGE 2500/3500 LONG ARM KIT					
63110	2009-2012	2009-2012 8" LONG ARM DODGE 2500/3500 4WD GAS BASIC KIT	22, 34, 48	8"	4WD
63120	2009-2012	2009-2012 8" LONG ARM DODGE 2500/3500 4WD DIESEL BASIC KIT	22, 34, 48	8"	4WD
63130	2003-2008	2003-2008 8" LONG ARM DODGE 2500/3500 4WD GAS BASIC KIT	22, 34, 48	8"	4WD
63140	2003-2008	2003-2008 8" LONG ARM DODGE 2500/3500 4WD DIESEL BASIC KIT	22, 34, 48	8"	4WD
DOUBLE FRONT SHOCK (1 INSIDE COIL 1 OUTSIDE COIL MOUNTED ON SHOCK HOOP)					
63900	2003-2012	DOUBLE FRONT SHOCK HOOPS (WORKS ONLY WITH LONG ARM KIT)	27, 39	8"	4WD
C2012-625R	2003-2012	FTS 2.0 REMOTE RESERVOIR 12" TRAVEL CHROME FINISH (INSIDE COIL)	29, 30	8"	4WD
B2012-625R	2003-2012	FTS 2.0 REMOTE RESERVOIR 12" TRAVEL BLACK FINISH (INSIDE COIL)	29, 31	8"	4WD
C2010-625R	2003-2012	FTS 2.0 REMOTE RESERVOIR 10" TRAVEL CHROME FINISH (MOUNTS ON HOOP)	29, 30	8"	4WD
B2010-625R	2003-2012	FTS 2.0 REMOTE RESERVOIR 10" TRAVEL BLACK FINISH (MOUNTS ON HOOP)	29, 31	8"	4WD
SINGLE FRONT SHOCK INSIDE COIL					
C2012-625ES	2003-2012	FTS 2.0 EMULSION 12" TRAVEL CHROME FINISH (INSIDE COIL STOCK LOCATION)	29, 30	8"	4WD
B2012-625ES	2003-2012	FTS 2.0 EMULSION 12" TRAVEL BLACK FINISH (INSIDE COIL STOCK LOCATION)	29, 31	8"	4WD
SINGLE REAR SHOCK STOCK LOCATION					
C2014-625R	2003-2012	FTS 2.0 REMOTE RESERVOIR 14" TRAVEL CHROME FINISH (STOCK REAR LOCATION)	29, 30	8"	4WD
B2014-625R	2003-2012	FTS 2.0 REMOTE RESERVOIR 14" TRAVEL BLACK FINISH (STOCK REAR LOCATION)	29, 31	8"	4WD
FRONT DRIVE LINE SPACER/RECKLING RING					
64000-9	2009-2012	10.4 DEGREE TRANSFER CASE RECKLING RING	44	8"	4WD
64000-12	2003-2008	10.4 DEGREE TRANSFER CASE RECKLING RING W/ SEAL ADAPTOR	44	8"	4WD
64000-10	2003-2012	2" FRONT DRIVE SHAFT SPACER W/ HARDWARE	59, 60	8"	4WD

ACCESSORIES

PART #	YEAR	TITLE	FOOTNOTES	LIFT SIZE	2WD / 4WD
BILLET SHOCK CLAMPS					
C2020	2003-2012	FTS 2.0 BILLET SHOCK CLAMPS CHROME FINISH	38	6"/8"	4WD
B2020	2003-2012	FTS 2.0 BILLET SHOCK CLAMPS BLACK FINISH	38	6"/8"	4WD
C2015	2003-2012	FTS 2.0 TO 1.5 BILLET SHOCK CLAMPS CHROME FINISH	38	6"/8"	4WD
B2015	2003-2012	FTS 2.0 TO 1.5 BILLET SHOCK CLAMPS BLACK FINISH	38	6"/8"	4WD
BRAKE LINES					
63801	2003-2011	FRONT / REAR STEEL BRAIDED BRAKE LINE KIT (W/ SINGLE REAR BRAKE LINE)	79	6"/8"	4WD
63802	2011-2012	FRONT / REAR STEEL BRAIDED BRAKE LINE KIT (W/ DUAL REAR BRAKE LINE)	79	6"/8"	4WD
REAR TRACTION BARS					
25963	2003-2012	BOLT ON TRACTION BAR KIT 63" (CREW CAB BED) W/ 3/4 U BOLTS	27, 56, 58	6"/8"	4WD
25968	2003-2012	BOLT ON TRACTION BAR KIT 68" (MEGA CAB BED) W/ 3/4 U BOLTS	27, 56, 58	6"/8"	4WD
DOUBLE STEERING STABILIZER KITS					
63846	2003-2012	DOUBLE FRONT STEERING STABILIZER KIT W/ BASIC HYDRAULIC STABILIZERS	56	6"/8"	4WD
63848	2003-2012	DOUBLE FRONT STEERING STABILIZER KIT W/ FTS 2.0 CHROME STABILIZERS	30, 56	6"/8"	4WD
63489	2003-2012	DOUBLE FRONT STEERING STABILIZER KIT W/ FTS 2.0 BLACK STABILIZERS	31, 56	6"/8"	4WD

10" 2003 - 2012 DODGE RAM 2500 / 3500

2003-2012
10" IN 10" DODGE RAM
2500 / 3500

Heavy duty long arm 4 link for superior ride quality and travel
Matched drop pitman arm and track bar bracket to reduce bump steer
No cutting of the factory control arm brackets
Full 10" coil with factory like ride
Rear offset lift blocks keep rear axle centered
Heavy duty semi gloss black powder for long life and great looks
No exhaust modification required

10" Kit Max Recommended Tire Size 38"-39" Max Recommended Wheel Width 40"

12" 2003-2012 Dodge Ram 2500 / 3500

Easy to install long arm brackets utilize factory transmission crossmember
Matched crossover steering knuckle and track bar bracket to reduce bump steer
Rear lift blocks along with lift shackles keep factory ride
Kit Includes Bolt On Tractor bars to eliminate axle wrap
Transfer case redlocking ring along with new front driveshaft to alleviate vibration

12" Kit Max Recommended Tire Size 40"-42" Max Recommended Wheel Width 10"



Basic 10" kit includes:

- 10" Front Box Kit
- 10" Coil Springs
- 7" Rear Block Kit
- Dual CV Front Drive Shaft w/ Axle Flange
- Bolt On Tractor Bars
- Front / Rear Steel Braided Brake Lines

Basic 12" kit includes:

- 12" Front Box Kit
- 10" Coil Springs plus 2" Spacer
- 8" Rear Block Kit w/ 2" Shackles
- Cross Over Steering Knuckle
- Transfercase Redlocking Ring
- Dual CV Front Drive Shaft w/ Axle Flange
- Bolt On Tractor Bars
- Front / Rear Steel Braided Brake Lines

Shocks Sold Separately.

Please see options below

10" DODGE RAM 2500 / 3500
LONG ARM KIT Part #63240

PART #	YEAR	TITLE	FOOTNOTES	LIFT SIZE	2WD / 4WD
10" DODGE 2500/3500 LONG ARM KIT					
63210	2009-2012	2009-2012 10" LONG ARM DODGE 2500/3500 4WD GAS BASIC KIT	22, 34, 48	10"	4WD
63220	2009-2012	2009-2012 10" LONG ARM DODGE 2500/3500 4WD DIESEL BASIC KIT	22, 34, 48	10"	4WD
63230	2003-2008	2003-2008 10" LONG ARM DODGE 2500/3500 4WD GAS BASIC KIT	22, 34, 48	10"	4WD
63240	2003-2008	2003-2008 10" LONG ARM DODGE 2500/3500 4WD DIESEL BASIC KIT	22, 34, 48	10"	4WD
REAR TRACTION BARS					
25963	2003-2012	BOLT ON TRACTION BAR KIT 63" (CREW CAB BED) W/ 3/4 U BOLTS	27, 56, 58	10"	4WD
25968	2003-2012	BOLT ON TRACTION BAR KIT 68" (MEGA CAB BED) W/ 3/4 U BOLTS	27, 56, 58	10"	4WD
2.5 REMOTE RESERVOIR COILOVER W/ LARGE RING					
C2511-875R	2003-2012	FTS 2.5 REMOTE RESERVOIR 11" TRAVEL COILOVER CHROME FINISH	10, 29, 30	10"	4WD
B2511-875R	2003-2012	FTS 2.5 REMOTE RESERVOIR 11" TRAVEL COILOVER BLACK FINISH	10, 29, 31	10"	4WD
SINGLE FRONT SHOCK INSIDE COIL					
C2014-625E5	2003-2012	FTS 2.0 EMULSION 14" TRAVEL CHROME FINISH (INSIDE COIL STOCK LOCATION)	29, 30	10"	4WD
B2014-625E5	2003-2012	FTS 2.0 EMULSION 14" TRAVEL BLACK FINISH (INSIDE COIL STOCK LOCATION)	29, 31	10"	4WD
DOUBLE FRONT SHOCK (1 INSIDE COIL 1 OUTSIDE COIL MOUNTED ON SHOCK HOOP					
63900	2003-2012	DOUBLE FRONT SHOCK HOOPS	27, 39	10"	4WD
C2012-625R	2003-2012	FTS 2.0 REMOTE RESERVOIR 12" TRAVEL CHROME FINISH (INSIDE COIL)	29, 30	10"	4WD
B2012-625R	2003-2012	FTS 2.0 REMOTE RESERVOIR 12" TRAVEL BLACK FINISH (INSIDE COIL)	29, 31	10"	4WD
C2010-625R	2003-2012	FTS 2.0 REMOTE RESERVOIR 11" TRAVEL CHROME FINISH (MOUNTS ON HOOP)	29, 30	10"	4WD
B2010-625R	2003-2012	FTS 2.0 REMOTE RESERVOIR 11" TRAVEL BLACK FINISH (MOUNTS ON HOOP)	29, 31	10"	4WD
SINGLE REAR SHOCK STOCK LOCATION					
C2014-625R	2003-2012	FTS 2.0 REMOTE RESERVOIR 14" TRAVEL CHROME FINISH (STOCK REAR LOCATION)	29, 30	10"	4WD
B2014-625R	2003-2012	FTS 2.0 REMOTE RESERVOIR 14" TRAVEL BLACK FINISH (STOCK REAR LOCATION)	29, 31	10"	4WD
C2512-875R	2003-2012	FTS 2.5 REMOTE RESERVOIR 12" TRAVEL CHROME FINISH (STOCK REAR LOCATION)	29, 30	10"	4WD
B2512-875R	2003-2012	FTS 2.5 REMOTE RESERVOIR 12" TRAVEL BLACK FINISH (STOCK REAR LOCATION)	29, 31	10"	4WD
BRAKE LINES					
63813	2003-2011	FRONT / REAR STEEL BRAIDED BRAKE LINE KIT (W/ SINGLE REAR BRAKE LINE)	79	10"	4WD
63814	2011-2012	FRONT / REAR STEEL BRAIDED BRAKE LINE KIT (W/ DUAL REAR BRAKE LINE)	79	10"	4WD
FRONT DRIVE LINE					
63500	2009-2012	DUAL CV FRONT DRIVE LINE W/ AXLE FLANGE W/ AUTOMATIC TRANSMISSION	35	10"	4WD
63501	2009-2012	DUAL CV FRONT DRIVE LINE W/ AXLE FLANGE W/ STANDARD TRANSMISSION	35	10"	4WD
63502	2003-2008	DUAL CV FRONT DRIVE LINE W/ AXLE FLANGE W/ AUTOMATIC TRANSMISSION	35	10"	4WD
63503	2003-2008	DUAL CV FRONT DRIVE LINE W/ AXLE FLANGE W/ STANDARD TRANSMISSION	35	10"	4WD
64000-17	2003-2012	FRONT AXLE FLANGE W/ HARDWARE	59, 60	10"	4WD
64000-9	2009-2012	10.4 DEGREE TRANSFER CASE RELOCKING RING	44	10"	4WD
64000-12	2003-2008	10.4 DEGREE TRANSFER CASE RELOCKING RING W/ SEAL ADAPTOR	44	10"	4WD



12" 2003 - 2012 DODGE RAM 2500 / 3500

12" DODGE RAM 2500 / 3500 LONG ARM KIT Part #63420



PART #	YEAR	TITLE	FOOTNOTES	LIFT SIZE	2WD / 4WD
12" DODGE 2500/3500 LONG ARM KIT					
63410	2009-2012	2009-2012 12" LONG ARM DODGE 2500/3500 4WD GAS BASIC KIT	22, 34, 48	12"	4WD
63420	2009-2012	2009-2012 12" LONG ARM DODGE 2500/3500 4WD DIESEL BASIC KIT	22, 34, 48	12"	4WD
63430	2003-2008	2003-2008 12" LONG ARM DODGE 2500/3500 4WD GAS BASIC KIT	22, 34, 48	12"	4WD
63440	2003-2008	2003-2008 12" LONG ARM DODGE 2500/3500 4WD DIESEL BASIC KIT	22, 34, 48	12"	4WD
63410-C	2009-2012	2009-2012 12" LONG ARM DODGE 2500/3500 4WD GAS W/ 2.5 FRONT COILOVER	22, 34, 48	12"	4WD
63420-C	2009-2012	2009-2012 12" LONG ARM DODGE 2500/3500 4WD DIESEL W/ 2.5 FRONT COILOVER	22, 34, 48	12"	4WD
63430-C	2003-2008	2003-2008 12" LONG ARM DODGE 2500/3500 4WD GAS W/ 2.5 FRONT COILOVER	22, 34, 48	12"	4WD
63440-C	2003-2008	2003-2008 12" LONG ARM DODGE 2500/3500 4WD DIESEL W/ 2.5 FRONT COILOVER	22, 34, 48	12"	4WD
REAR TRACTION BARS					
25968	2003-2012	BOLT ON TRACTION BAR KIT 68" (CREW CAB BED) W/ 3/4" U BOLTS	27, 56, 58	12"	4WD
25974	2003-2012	BOLT ON TRACTION BAR KIT 74" (MEGA CAB BED) W/ 3/4" U BOLTS	27, 56, 58	12"	4WD
2.5 REMOTE RESERVOIR COILOVER W/ LARGE RING					
C2512-875R	2003-2012	FTS 2.5 REMOTE RESERVOIR 12" TRAVEL COILOVER CHROME FINISH	10, 29, 30	12"	4WD
B2512-875R	2003-2012	FTS 2.5 REMOTE RESERVOIR 12" TRAVEL COILOVER BLACK FINISH	10, 29, 31	12"	4WD
C2515	2003-2012	FTS 2.5 TO 1.5 BILLET SHOCK CLAMPS CHROME FINISH	38	12"	4WD
B2515	2003-2012	FTS 2.5 TO 1.5 BILLET SHOCK CLAMPS BLACK FINISH	38	12"	4WD
DOUBLE FRONT SHOCK HOOPS					
63900	2003-2012	DOUBLE FRONT SHOCK HOOPS	27, 39	12"	4WD
C2012-625R	2003-2012	FTS 2.0 REMOTE RESERVOIR 12" TRAVEL CHROME FINISH (MOUNTS ON HOOP)	29, 30	12"	4WD
B2012-625R	2003-2012	FTS 2.0 REMOTE RESERVOIR 12" TRAVEL BLACK FINISH (MOUNTS ON HOOP)	29, 31	12"	4WD
SINGLE REAR SHOCK STOCK LOCATION					
C2016-875R	2003-2012	FTS 2.0 REMOTE RESERVOIR 16" TRAVEL CHROME FINISH (STOCK REAR LOCATION)	29, 30	12"	4WD
B2016-875R	2003-2012	FTS 2.0 REMOTE RESERVOIR 16" TRAVEL BLACK FINISH (STOCK REAR LOCATION)	29, 31	12"	4WD
C2514-875R	2003-2012	FTS 2.5 REMOTE RESERVOIR 14" TRAVEL CHROME FINISH (STOCK REAR LOCATION)	29, 30	12"	4WD
B2514-875R	2003-2012	FTS 2.5 REMOTE RESERVOIR 14" TRAVEL BLACK FINISH (STOCK REAR LOCATION)	29, 31	12"	4WD
BRAKE LINES					
63815	2003-2011	FRONT / REAR STEEL BRAIDED BRAKE LINE KIT (W/ SINGLE REAR BRAKE LINE)	79	12"	4WD
63816	2011-2012	FRONT / REAR STEEL BRAIDED BRAKE LINE KIT (W/ DUAL REAR BRAKE LINE)	79	12"	4WD
FRONT DRIVE LINE					
63504	2009-2012	DUAL CV FRONT DRIVE LINE W/ AXLE FLANGE W/ AUTOMATIC TRANSMISSION	35	12"	4WD
63505	2009-2012	DUAL CV FRONT DRIVE LINE W/ AXLE FLANGE W/ STANDARD TRANSMISSION	35	12"	4WD
63506	2003-2008	DUAL CV FRONT DRIVE LINE W/ AXLE FLANGE W/ AUTOMATIC TRANSMISSION	35	12"	4WD
63507	2003-2008	DUAL CV FRONT DRIVE LINE W/ AXLE FLANGE W/ STANDARD TRANSMISSION	35	12"	4WD
64000-17	2003-2012	FRONT AXLE FLANGE W/ HARDWARE	59, 60	12"	4WD
REAR DRIVE LINE SPACER					
63870	2003-2012	2" REAR DRIVE SHAFT SPACER	59, 60	12"	4WD
RELOCKING RING					
64000-18	2009-2012	14 DEGREE TRANSFER CASE RELOCKING RING	44	12"	4WD
64000-19	2003-2008	14 DEGREE TRANSFER CASE RELOCKING RING W/ SEAL ADAPTOR	44	12"	4WD
ACCESSORIES					
63846	2003-2012	DOUBLE FRONT STEERING STABILIZER KIT W/ BASIC HYDRAULIC STABILIZERS	56	ALL	4WD
63848	2003-2012	DOUBLE FRONT STEERING STABILIZER KIT W/ FTS 2.0 CHROME STABILIZERS	30, 56	ALL	4WD
63489	2003-2012	DOUBLE FRONT STEERING STABILIZER KIT W/ FTS 2.0 BLACK STABILIZERS	31, 56	ALL	4WD

15" 2003 - 2012 DODGE RAM 2500 / 3500

Heavy duty long arm construction for superior ride quality and travel
 Lower Arms constructed of 1.75" DOM tubing w/ urethane bushing on both ends
 Extended Links are over 3X's the length of the factory arms
 Easy to install long arm brackets utilize factory transmission crossmember
 Moves front axle forward for better fender clearance
 Matched pitman arm drop and track bar bracket to reduce bumpsteer
 Full 10" Coil Spring plus 5" Spacer w/ Basic Kit
 New transmission mount to alleviate driveline vibration
 Rear lift is accomplished w/ rear leaf springs and lift blocks
 Heavy duty semi gloss black powder for long life and great looks
 Transfer case reclocking ring to alleviate driveline vibration
 Dual CV Front Drive Shaft
 Bolt On Traction Bars available to eliminate axle wrap
 Kits are available with replacement Coil Springs or upgradable Coilover conversion



Basic 15" kit includes:
 15" Front Box Kit
 10" Coil Springs plus 5" Spacer
 13" Rear Leaf Springs
 2" Rear Block Kit
 CV Front Drive Shaft
 Crossover Steering Knuckle
 Transfercase Reclocking Ring

Upgraded 15" kit includes:
 15" Front Box Kit
 10" Coil Springs
 2.5 FTS Coilovers R/R
 13" Rear Leaf Springs
 2" Rear Block Kit
 CV Front Drive Shaft
 Crossover Steering Knuckle
 Transfercase Reclocking Ring

Shocks Sold Separately.
 Please see options below

15" Kit Max Recommended Tire Size 44" Max Recommended Wheel Width 12"

PART #	YEAR	TITLE	FOOTNOTES	LIFT SIZE	2WD / 4WD
15" DODGE 2500/3500 LONG ARM KIT					
63510	2009-2012	2009-2012 15" LONG ARM DODGE 2500/3500 4WD GAS BASIC KIT	22, 34, 48	15"	4WD
63520	2009-2012	2009-2012 15" LONG ARM DODGE 2500/3500 4WD DIESEL BASIC KIT	22, 34, 48	15"	4WD
63530	2003-2008	2003-2008 15" LONG ARM DODGE 2500/3500 4WD GAS BASIC KIT	22, 34, 48	15"	4WD
63540	2003-2008	2003-2008 15" LONG ARM DODGE 2500/3500 4WD DIESEL BASIC KIT	22, 34, 48	15"	4WD
63510-C	2009-2012	2009-2012 15" LONG ARM DODGE 2500/3500 4WD GAS W/ 2.5 FRONT COILOVER	22, 34, 48	15"	4WD
63520-C	2009-2012	2009-2012 15" LONG ARM DODGE 2500/3500 4WD DIESEL W/ 2.5 FRONT COILOVER	22, 34, 48	15"	4WD
63530-C	2003-2008	2003-2008 15" LONG ARM DODGE 2500/3500 4WD GAS W/ 2.5 FRONT COILOVER	22, 34, 48	15"	4WD
63540-C	2003-2008	2003-2008 15" LONG ARM DODGE 2500/3500 4WD DIESEL W/ 2.5 FRONT COILOVER	22, 34, 48	15"	4WD
REAR TRACTION BARS					
25968	2003-2012	BOLT ON TRACTION BAR KIT 68" (CREW CAB BED) W/ 3/4" U BOLTS	27, 56, 58	15"	4WD
25974	2003-2012	BOLT ON TRACTION BAR KIT 74" (MEGA CAB BED) W/ 3/4" U BOLTS	27, 56, 58	15"	4WD
2.5 REMOTE RESERVOIR COILOVER W/ LARGE RING					
C2514-875R	2003-2012	FTS 2.5 REMOTE RESERVOIR 14" TRAVEL COILOVER CHROME FINISH	10, 29, 30	15"	4WD
B2514-875R	2003-2012	FTS 2.5 REMOTE RESERVOIR 14" TRAVEL COILOVER BLACK FINISH	10, 29, 31	15"	4WD
C2515	2003-2012	FTS 2.5 TO 1.5 BILLET SHOCK CLAMPS CHROME FINISH	38	15"	4WD
B2515	2003-2012	FTS 2.5 TO 1.5 BILLET SHOCK CLAMPS BLACK FINISH	38	15"	4WD
DOUBLE FRONT SHOCK HOOPS					
63900	2003-2012	DOUBLE FRONT SHOCK HOOPS	27, 39	15"	4WD
C2014-625R	2003-2012	FTS 2.0 REMOTE RESERVOIR 14" TRAVEL CHROME FINISH (MOUNTS ON HOOP)	29, 30	15"	4WD
B2014-625R	2003-2012	FTS 2.0 REMOTE RESERVOIR 14" TRAVEL BLACK FINISH (MOUNTS ON HOOP)	29, 31	15"	4WD
SINGLE REAR SHOCK STOCK LOCATION					
C2016-875R	2003-2012	FTS 2.0 REMOTE RESERVOIR 16" TRAVEL CHROME FINISH (STOCK REAR LOCATION)	29, 30	15"	4WD
B2016-875R	2003-2012	FTS 2.0 REMOTE RESERVOIR 16" TRAVEL BLACK FINISH (STOCK REAR LOCATION)	29, 31	15"	4WD
C2516-875R	2003-2012	FTS 2.5 REMOTE RESERVOIR 16" TRAVEL CHROME FINISH (STOCK REAR LOCATION)	29, 30	15"	4WD
B2516-875R	2003-2012	FTS 2.5 REMOTE RESERVOIR 16" TRAVEL BLACK FINISH (STOCK REAR LOCATION)	29, 31	15"	4WD
BRAKE LINES					
63815	2003-2011	FRONT / REAR STEEL BRAIDED BRAKE LINE KIT (W/ SINGLE REAR BRAKE LINE)	79	15"	4WD
63816	2011-2012	FRONT / REAR STEEL BRAIDED BRAKE LINE KIT (W/ DUAL REAR BRAKE LINE)	79	15"	4WD
FRONT DRIVE LINE					
63508	2009-2012	DUAL CV FRONT DRIVE LINE W/ AXLE FLANGE W/ AUTOMATIC TRANSMISSION	35	15"	4WD
63509	2009-2012	DUAL CV FRONT DRIVE LINE W/ AXLE FLANGE W/ STANDARD TRANSMISSION	35	15"	4WD
63510	2003-2008	DUAL CV FRONT DRIVE LINE W/ AXLE FLANGE W/ AUTOMATIC TRANSMISSION	35	15"	4WD
63511	2003-2008	DUAL CV FRONT DRIVE LINE W/ AXLE FLANGE W/ STANDARD TRANSMISSION	35	15"	4WD
64000-17	2003-2012	FRONT AXLE FLANGE W/ HARDWARE	59, 60	15"	4WD
REAR DRIVE LINE SPACER					
63870	2003-2012	2" REAR DRIVE SHAFT SPACER	59, 60	15"	4WD
RECKLOCKING RING					
64000-21	2009-2012	40 DEGREE TRANSFER CASE RECKLOCKING RING	44	15"	4WD
64000-22	2003-2008	40 DEGREE TRANSFER CASE RECKLOCKING RING W/ SEAL ADAPTOR	44	15"	4WD
ACCESSORIES					
63846	2003-2012	DOUBLE FRONT STEERING STABILIZER KIT W/ BASIC HYDRAULIC STABILIZERS	56	ALL	4WD
63848	2003-2012	DOUBLE FRONT STEERING STABILIZER KIT W/ FTS 2.0 CHROME STABILIZERS	30, 56	ALL	4WD
63489	2003-2012	DOUBLE FRONT STEERING STABILIZER KIT W/ FTS 2.0 BLACK STABILIZERS	31, 56	ALL	4WD
D11-10	2003-2012	10" REAR LEAF SPRINGS	31, 56	ALL	4WD
D11-13	2003-2012	13" REAR LEAF SPRINGS	31, 56	ALL	4WD

15" DODGE RAM 2500 / 3500
 BASIC KIT Part # 63540



15" DODGE RAM 2500 / 3500
 W/ COILOVERS Part # 63520C

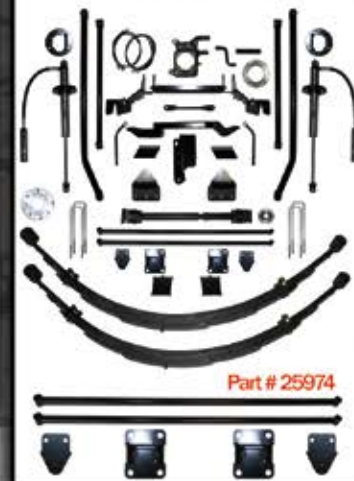

Part # 25974



2.5 Coilover with Large Diameter Ring
 Designed to run a factory diameter Coil



Dual Steering Stabilizer Kit w/ FTS 2.0 Stabilizer Shocks



Crossover Steering Knuckle Kit

4" 2005 - 2013 FORD F-250 / F-350

4" FORD F-250 / F-350 2004-2013

- 100% Bolt On
- 4" or 6" Coil Spring with factory like ride
- Forged pitman arm and track bar drop bracket matched for problem free steering
- Easy to install radius arm drop brackets or optional replacement radius arm
- Rear lift block to maintain factory ride and load capacity
- Maintains factory steering dampener

Options:
 Double front shock upgrade with FTS 2.0 Shocks
 Bolt On Traction Bars, Dual Steering Stabilizer

4" 4wd Kit Max Recommended Tire Size: 35" Max Recommended Wheel Width: 10"
 6" 4wd Kit Max Recommended Tire Size: 35" Max Recommended Wheel Width: 10"

Basic 4wd 4" kit includes:
 4" Front Box Kit
 2" Rear Block Kit
 4" Front Coil Springs

Basic 4wd 6" kit includes:
 6" Front Box Kit
 4" Rear Block Kit
 6" Front Coil Springs

Shocks Sold Separately
 Please see options below



4" 4WD 2005-2007 FORD F-250
 RADIUS ARM KIT Part #86541



4" 4WD 2008-2012 FORD F-250
 RADIUS ARM KIT Part #87541



4" 4WD 2005-2007 FORD F-250
 BASIC KIT Part #86540



PART #	YEAR	TITLE	FOOTERNOTES	LIFT SIZE	2WD / 4WD
4" 2005-2012 FORD F250/350 4WD					
86540	2005-2007	2005-2007 FORD F250 4" BASIC KIT W/ REAR BLOCKS	59	4"	4WD
86542	2005-2007	2005-2007 FORD F350 4" BASIC KIT W/ REAR BLOCKS	59	4"	4WD
86541	2005-2007	2005-2007 FORD F250 4" RADIUS ARM KIT W/ REAR BLOCKS	59	4"	4WD
86543	2005-2007	2005-2007 FORD F350 4" RADIUS ARM KIT W/ REAR BLOCKS	59	4"	4WD
87540	2008-2013	2008-2012 FORD F250 4" BASIC KIT W/ REAR BLOCKS	59	4"	4WD
87542	2008-2013	2008-2012 FORD F350 4" BASIC KIT W/ REAR BLOCKS	59	4"	4WD
87541	2008-2013	2008-2012 FORD F250 4" RADIUS ARM KIT W/ REAR BLOCKS	59	4"	4WD
87543	2008-2013	2008-2012 FORD F350 4" RADIUS ARM KIT W/ REAR BLOCKS	59	4"	4WD
SINGLE FRONT SHOCK STOCK LOCATION					
C2011-625RS	2005-2012	FTS 2.0 REMOTE RESERVOIR 10" TRAVEL CHROME FINISH (STOCK FRONT LOCATION)	29, 30	4"	4WD
B2011-625RS	2005-2012	FTS 2.0 REMOTE RESERVOIR 10" TRAVEL BLACK FINISH (STOCK FRONT LOCATION)	29, 31	4"	4WD
DOUBLE FRONT SHOCK					
86510-4	2005-2013	DOUBLE FRONT SHOCK HOOPS KIT	27, 81	4"	4WD
C2090-625R	2005-2013	FTS 2.0 REMOTE RESERVOIR 9.0" TRAVEL CHROME FINISH (DOUBLE SHOCK)	29, 30	4"	4WD
B2090-625R	2005-2013	FTS 2.0 REMOTE RESERVOIR 9.0" TRAVEL BLACK FINISH (DOUBLE SHOCK)	29, 31	4"	4WD
SINGLE REAR SHOCK STOCK LOCATION					
C2012-625R	2005-2012	FTS 2.0 REMOTE RESERVOIR 12" TRAVEL CHROME FINISH (STOCK REAR LOCATION)	29, 30	4"	4WD
B2012-625R	2005-2012	FTS 2.0 REMOTE RESERVOIR 12" TRAVEL BLACK FINISH (STOCK REAR LOCATION)	29, 31	4"	4WD
BILLET SHOCK CLAMPS					
C2020	2007-2013	FTS 2.0 TO 2.0 BILLET SHOCK CLAMPS CHROME FINISH	38	4"	4WD
B2020	2007-2013	FTS 2.0 TO 2.0 BILLET SHOCK CLAMPS BLACK FINISH	38	4"	4WD
ACCESSORIES					
86522	2005-2010	FRONT / REAR STEEL BRAIDED BRAKE LINE KIT (SINGLE REAR)	79	4"	4WD
87527	2011-2013	FRONT / REAR STEEL BRAIDED BRAKE LINE KIT (DUAL REAR)	79	4"	4WD
86500	2005-2013	DOUBLE FRONT STEERING STABILIZER KIT W/ BASIC HYDRAULIC STABILIZERS	56	4"	4WD
86501	2005-2013	DOUBLE FRONT STEERING STABILIZER KIT W/ FTS 2.0 CHROME STABILIZERS	30, 56	4"	4WD
86502	2005-2013	DOUBLE FRONT STEERING STABILIZER KIT W/ FTS 2.0 BLACK STABILIZERS	31, 56	4"	4WD
28968	2005-2013	BOLT ON TRACTION BAR KIT 68" SHORT BED	27, 56, 58	4"	4WD
28974	2005-2013	BOLT ON TRACTION BAR KIT 74" LONG BED	27, 56, 58	4"	4WD

6" 4WD 2005-2007 FORD F-250
 RADIUS ARM KIT Part #86561



6" 4WD 2008-2012 FORD F-250
 RADIUS ARM KIT Part #87561



6" 4WD 2008-2012 FORD F-250
 BASIC KIT Part #87560



6" 2005 - 2013 FORD F-250 / F-350

PART #	YEAR	TITLE	FOOTERNOTES	LIFT SIZE	2WD / 4WD
6" 2005-2012 FORD F250/350 4WD					
86560	2005-2007	2005-2007 FORD F250 6" BASIC KIT W/ REAR BLOCKS	59, 80	6"	4WD
86562	2005-2007	2005-2007 FORD F350 6" BASIC KIT W/ REAR BLOCKS	59, 80	6"	4WD
86561	2005-2007	2005-2007 FORD F250 6" RADIUS ARM KIT W/ REAR BLOCKS	59, 80	6"	4WD
86563	2005-2007	2005-2007 FORD F350 6" RADIUS ARM KIT W/ REAR BLOCKS	59, 80	6"	4WD
87560	2008-2013	2008-2012 FORD F250 6" BASIC KIT W/ REAR BLOCKS	59, 80	6"	4WD
87562	2008-2013	2008-2012 FORD F350 6" BASIC KIT W/ REAR BLOCKS	59, 80	6"	4WD
87561	2008-2013	2008-2012 FORD F250 6" RADIUS ARM KIT W/ REAR BLOCKS	59, 80	6"	4WD
87563	2008-2013	2008-2012 FORD F350 6" RADIUS ARM KIT W/ REAR BLOCKS	59, 80	6"	4WD
SINGLE FRONT SHOCK STOCK LOCATION					
C2010-625RS	2005-2013	FTS 2.0 REMOTE RESERVOIR 11" TRAVEL CHROME FINISH (STOCK FRONT LOCATION)	29, 30	6"	4WD
B2010-625RS	2005-2013	FTS 2.0 REMOTE RESERVOIR 11" TRAVEL BLACK FINISH (STOCK FRONT LOCATION)	29, 31	6"	4WD
DOUBLE FRONT SHOCK					
86510-6	2005-2013	DOUBLE FRONT SHOCK HOOPS KIT	27, 81	6"	4WD
C2010-625R	2005-2013	FTS 2.0 REMOTE RESERVOIR 10" TRAVEL CHROME FINISH (DOUBLE SHOCK)	29, 30	6"	4WD
B2010-625R	2005-2013	FTS 2.0 REMOTE RESERVOIR 10" TRAVEL BLACK FINISH (DOUBLE SHOCK)	29, 31	6"	4WD
2.5" COIL OVER KIT W/ COILS					
C2580-875EC	2005-2012	FTS 2.5" X 8.0" EMULSION COILOVER W/ COILS CHROME FINISH	10, 33	6"	4WD
B2580-875EC	2005-2012	FTS 2.5" X 8.0" EMULSION COILOVER W/ COILS BLACK FINISH	10, 33	6"	4WD
C2580-875RC	2005-2012	FTS 2.5" X 8.0" REMOTE RESERVOIR COILOVER W/ COILS CHROME FINISH	10, 33, 57	6"	4WD
B2580-875RC	2005-2012	FTS 2.5" X 8.0" REMOTE RESERVOIR COILOVER W/ COILS BLACK FINISH	10, 33, 57	6"	4WD
86530	2005-2013	2.5 COIL OVER BRACKETS W/ SPACERS (SHORT)	27	6"	4WD
SINGLE REAR SHOCK STOCK LOCATION					
C2012-625R	2005-2013	FTS 2.0 REMOTE RESERVOIR 12" TRAVEL CHROME FINISH (STOCK REAR LOCATION)	29, 30	6"	4WD
B2012-625R	2005-2013	FTS 2.0 REMOTE RESERVOIR 12" TRAVEL BLACK FINISH (STOCK REAR LOCATION)	29, 31	6"	4WD
BILLET SHOCK CLAMPS					
C2020	2007-2013	FTS 2.0 TO 2.0 BILLET SHOCK CLAMPS CHROME FINISH	38	6"	4WD
B2020	2007-2013	FTS 2.0 TO 2.0 BILLET SHOCK CLAMPS BLACK FINISH	38	6"	4WD
ACCESSORIES					
86522	2005-2010	FRONT / REAR STEEL BRAIDED BRAKE LINE KIT (SINGLE REAR)	79	6"	4WD
87527	2011-2013	FRONT / REAR STEEL BRAIDED BRAKE LINE KIT (DUAL REAR)	79	6"	4WD
86500	2005-2013	DOUBLE FRONT STEERING STABILIZER KIT W/ BASIC HYDRAULIC STABILIZERS	56	6"	4WD
86501	2005-2013	DOUBLE FRONT STEERING STABILIZER KIT W/ FTS 2.0 CHROME STABILIZERS	30, 56	6"	4WD
86502	2005-2013	DOUBLE FRONT STEERING STABILIZER KIT W/ FTS 2.0 BLACK STABILIZERS	31, 56	6"	4WD
28968	2005-2013	BOLT ON TRACTION BAR KIT 68" SHORT BED	27, 56, 58	6"	4WD
28974	2005-2013	BOLT ON TRACTION BAR KIT 74" LONG BED	27, 56, 58	6"	4WD

8" 2005 - 2013 FORD F-250 / F-350

100% bolt on
8" or 10" Coil Spring with factory like ride
Forged pitman arm and track bar drop bracket matched for problem free steering
Easy to install radius arm drop brackets or optional replacement radius arm
Rear Leaf Spring and lift block to achieve lift height
Maintains factory steering dampener

Options:

Double front shock upgrade with FTS 2.0 Shocks
Bolt On Traction Bars, Dual Steering Stabilizer, Crossover Steering Kit

8" 4wd kit Max Recommended Tire Size 37" Max Recommended Wheel Width 10"
10" 4wd kit Max Recommended Tire Size 40" Max Recommended Wheel Width 10"



Shocks Sold Separately
Coilover Upgrade Available
Please see options below

8" 4WD 2005-2007 FORD F-250
RADIUS ARM KIT Part #86581



8" 4WD 2008-2013 FORD F-250
BASIC KIT Part #87584



8" 2WD 2005-2007 FORD F-250
BASIC KIT Part #86580



PART #	YEAR	TITLE	FOOTERNOTES	LIFT SIZE	2WD / 4WD
8" 2005-2012 FORD F250/350 4WD					
86580	2005-2007	2005-2007 FORD F250 8" BASIC KIT W/ REAR SPRINGS	59, 80	8"	4WD
86582	2005-2007	2005-2007 FORD F350 8" BASIC KIT W/ REAR SPRINGS	59, 80	8"	4WD
86581	2005-2007	2005-2007 FORD F250 8" RADIUS ARM KIT W/ REAR SPRINGS	59, 80	8"	4WD
86583	2005-2007	2005-2007 FORD F350 8" RADIUS ARM KIT W/ REAR SPRINGS	59, 80	8"	4WD
87580	2008-2013	2008-2012 FORD F250 8" BASIC KIT W/ REAR SPRINGS	59, 80	8"	4WD
87582	2008-2013	2008-2012 FORD F350 8" BASIC KIT W/ REAR SPRINGS	59, 80	8"	4WD
87581	2008-2013	2008-2012 FORD F250 8" RADIUS ARM KIT W/ REAR SPRINGS	59, 80	8"	4WD
87583	2008-2013	2008-2012 FORD F350 8" RADIUS ARM KIT W/ REAR SPRINGS	59, 80	8"	4WD
SINGLE FRONT SHOCK STOCK LOCATION					
C2012-625RS	2005-2013	FTS 2.0 REMOTE RESERVOIR 12" TRAVEL CHROME FINISH (STOCK FRONT LOCATION)	29, 30	8"	4WD
B2012-625RS	2005-2013	FTS 2.0 REMOTE RESERVOIR 12" TRAVEL BLACK FINISH (STOCK FRONT LOCATION)	29, 31	8"	4WD
DOUBLE FRONT SHOCK					
86510-8	2005-2013	DOUBLE FRONT SHOCK HOOPS KIT	51	8"	4WD
C2011-625R	2005-2013	FTS 2.0 REMOTE RESERVOIR 11" TRAVEL CHROME FINISH (DOUBLE SHOCK)	29, 30	8"	4WD
B2011-625R	2005-2013	FTS 2.0 REMOTE RESERVOIR 11" TRAVEL BLACK FINISH (DOUBLE SHOCK)	29, 31	8"	4WD
2.5" COIL OVER KIT W/ COILS					
E2580-875C	2005-2012	FTS 2.5" X 8.0" EMULSION COILOVER W/ COILS	10, 33	8"	4WD
R2580-875C	2005-2012	FTS 2.5" X 8.0" REMOTE RESERVOIR COILOVER W/ COILS	10, 33, 57	8"	4WD
86531	2005-2013	2.5 COIL OVER BRACKETS W/ SPACERS (TALL)	27	8"	4WD
SINGLE REAR SHOCK STOCK LOCATION					
C2014-625R	2005-2013	FTS 2.0 REMOTE RESERVOIR 14" TRAVEL CHROME FINISH (STOCK REAR LOCATION)	29, 30	8"	4WD
B2014-625R	2005-2013	FTS 2.0 REMOTE RESERVOIR 14" TRAVEL BLACK FINISH (STOCK REAR LOCATION)	29, 31	8"	4WD
ACCESSORIES					
86523	2005-2010	FRONT / REAR STEEL BRAIDED BRAKE LINE KIT (SINGLE REAR)	79	8"	4WD
87528	2011-2013	FRONT / REAR STEEL BRAIDED BRAKE LINE KIT (DUAL REAR)	79	8"	4WD
86500	2005-2013	DOUBLE FRONT STEERING STABILIZER KIT W/ BASIC HYDRAULIC STABILIZERS	56	8"	4WD
86501	2005-2013	DOUBLE FRONT STEERING STABILIZER KIT W/ FTS 2.0 CHROME STABILIZERS	30, 56	8"	4WD
86502	2005-2013	DOUBLE FRONT STEERING STABILIZER KIT W/ FTS 2.0 BLACK STABILIZERS	31, 56	8"	4WD
28968	2005-2013	BOLT ON TRACTION BAR KIT 68" SHORT BED	27, 56, 58	8"	4WD
28974	2005-2013	BOLT ON TRACTION BAR KIT 74" LONG BED	27, 56, 58	8"	4WD

10" 4WD 2005-2007 FORD F-250
RADIUS ARM KIT Part #866311



10" 4WD 2008-2013 FORD F-250
RADIUS ARM KIT Part #87512



10" 4WD 2008-2013 FORD F-250
BASIC KIT Part #87510



Basic 4wd 8" kit includes:

- 8" Front Box Kit
- 8" Front Coil Springs
- 3" Rear Block Kit
- 5" Rear Leaf Springs

Basic 4wd 10" kit includes:

- 10" Front Box Kit
- 10" Front Coil Springs
- 5" Rear Block Kit
- 5" Rear Leaf Springs

Upgraded 4wd 10" kit includes:

- 10" Front Box Kit
- 10" Front Coil Springs
- Crossover Steering Knuckle Kit
- 5" Rear Block Kit
- 5" Rear Leaf Springs

10" 2005 - 2013 FORD F-250 / F-350

PART #	YEAR	TITLE	FOOTERNOTES	LIFT SIZE	2WD / 4WD
10" 2005-2013 FORD F250/350 4WD					
86510	2005-2007	2005-2007 FORD F250/350 10" BASIC KIT W/ REAR SPRINGS	59, 80	10"	4WD
86511	2005-2007	2005-2007 FORD F250/350 10" RADIUS ARM KIT W/ REAR SPRINGS	59, 80	10"	4WD
86512	2005-2007	2005-2007 FORD F250/350 10" RADIUS ARM KIT W/ REAR SPRINGS W/ CROSSOVER	59, 80	10"	4WD
87510	2008-2013	2008-2013 FORD F250/350 10" BASIC KIT W/ REAR SPRINGS	59, 80	10"	4WD
87511	2008-2013	2008-2013 FORD F250/350 10" RADIUS ARM KIT W/ REAR SPRINGS	59, 80	10"	4WD
87512	2008-2013	2008-2013 FORD F250/350 10" RADIUS ARM KIT W/ REAR SPRINGS W/ CROSSOVER	59, 80	10"	4WD
SINGLE FRONT SHOCK STOCK LOCATION					
C2012-625RS	2005-2012	FTS 2.0 REMOTE RESERVOIR 12" TRAVEL CHROME FINISH (STOCK FRONT LOCATION)	29, 30	10"	4WD
B2012-625RS	2005-2012	FTS 2.0 REMOTE RESERVOIR 12" TRAVEL BLACK FINISH (STOCK FRONT LOCATION)	29, 31	10"	4WD
DOUBLE FRONT SHOCK					
86510-10	2005-2013	DOUBLE FRONT SHOCK HOOPS KIT (WILL NOT FIT WITH CROSSOVER STEERING)	51	10"	4WD
C2012-625R	2005-2013	FTS 2.0 REMOTE RESERVOIR 12" TRAVEL CHROME FINISH (DOUBLE SHOCK)	29, 30	10"	4WD
B2012-625R	2005-2013	FTS 2.0 REMOTE RESERVOIR 12" TRAVEL BLACK FINISH (DOUBLE SHOCK)	29, 31	10"	4WD
2.5" COIL OVER KIT W/ COILS					
E2510-875C	2005-2012	FTS 2.5" X 10" EMULSION COILOVER W/ COILS	10, 33	10"	4WD
R2510-875C	2005-2012	FTS 2.5" X 10" REMOTE RESERVOIR COILOVER W/ COILS	10, 33, 57	10"	4WD
86530	2005-2013	2.5 COIL OVER BRACKETS W/ SPACERS (SHORT)	27	10"	4WD
SINGLE REAR SHOCK STOCK LOCATION					
C2014-625R	2005-2012	FTS 2.0 REMOTE RESERVOIR 14" TRAVEL CHROME FINISH (STOCK REAR LOCATION)	29, 30	10"	4WD
B2014-625R	2005-2012	FTS 2.0 REMOTE RESERVOIR 14" TRAVEL BLACK FINISH (STOCK REAR LOCATION)	29, 31	10"	4WD
BILLET SHOCK CLAMPS					
C2020	2007-2013	FTS 2.0 BILLET SHOCK CLAMPS CHROME FINISH	38	10"	4WD
B2020	2007-2013	FTS 2.0 BILLET SHOCK CLAMPS BLACK FINISH	38	10"	4WD
ACCESSORIES					
86523	2005-2010	FRONT / REAR STEEL BRAIDED BRAKE LINE KIT (SINGLE REAR)	79	10"	4WD
87528	2011-2013	FRONT / REAR STEEL BRAIDED BRAKE LINE KIT (DUAL REAR)	79	10"	4WD
87546	2005-2012	DOUBLE FRONT STEERING STABILIZER KIT W/ BASIC HYDRAULIC STABILIZER KIT	56	ALL	4WD
87547	2005-2012	DOUBLE FRONT STEERING STABILIZER KIT W/ FTS 2.0 CHROME STABILIZER KIT	30, 56	ALL	4WD
87548	2005-2012	DOUBLE FRONT STEERING STABILIZER KIT W/ FTS 2.0 BLACK STABILIZER KIT	31, 56	ALL	4WD
28974	2005-2012	BOLT ON TRACTION BAR KIT 74" SHORT BED	27, 56, 58	10"	4WD
28980	2005-2012	BOLT ON TRACTION BAR KIT 80" LONG BED	27, 56, 58	10"	4WD
86700	2005-2010	TRANSFER CASE RELOCKING RING	65	10"	4WD
86705	2005-2013	CROSSOVER STEERING KNUCKLE KIT	48, 49	10"	4WD
86708	2005-2013	CROSSOVER STEERING TRACK BAR KIT	50	10"	4WD

12" 2005 - 2013 FORD F-250 / F-350

12" INCH
14" INCH
2005-2013
FORD
F250 / F350

FTS Coilover shocks with factory rate coils for superior ride
Extra long 4 link arms use high flex, rebuildable, and greaseable joints
Ductile iron crossover steering knuckle
Forged drop pitman arm
Crossover track bar kit with adjustable track bar
Extended swaybar endlinks for bind free travel

12" 4wd kit Max Recommended Tire Size 40" Max Recommended Wheel Width 12"
14" 4wd kit Max Recommended Tire Size 42" Max Recommended Wheel Width 12"

Basic 4wd 12" kit includes:

12" Front Box Kit
Crossover Steering Knuckle Kit
Crossover Trackbar kit
10" Front Coil Springs
2" Coil Spacer
5" Rear Block Kit
7" Rear Leaf Springs

Basic 4wd 14" kit includes:

14" Front Box Kit
Crossover Steering Knuckle Kit
Crossover Trackbar kit
10" Front Coil Springs
4" Coil Spacer
7" Rear Block Kit
7" Rear Leaf Springs

Shocks Sold Separately,
Coilover Upgrade available
Please see options below



12" 4WD 2008-2013 FORD F-250 / F-350
LONG ARM KIT Part #87612

PART #	YEAR	TITLE	FOOTERNOTES	LIFT SIZE	2WD / 4WD
12" 2008-2012 FORD F250/350 4WD					
86612	2005-2007	2005-2007 FORD F250/350 12" LONG ARM KIT W/ REAR SPRINGS W/ CROSSOVER	59,80	12"	4WD
87612	2008-2013	2008-2013 FORD F250/350 12" LONG ARM KIT W/ REAR SPRINGS W/ CROSSOVER	59,80	12"	4WD
SINGLE FRONT SHOCK STOCK LOCATION					
C2014-625RS	2005-2012	FTS 2.0 REMOTE RESERVOIR 14" TRAVEL CHROME FINISH (STOCK FRONT LOCATION)	29,30	12"	4WD
B2014-625RS	2005-2012	FTS 2.0 REMOTE RESERVOIR 14" TRAVEL BLACK FINISH (STOCK FRONT LOCATION)	29,31	12"	4WD
2.5 COIL OVER KIT W/ COILS					
E2510-875C	2005-2012	FTS 2.5" X 10" EMULSION COILOVER W/ COILS	10,33	12"	4WD
R2510-875C	2005-2012	FTS 2.5" X 10" REMOTE RESERVOIR COILOVER W/ COILS	10,33,57	12"	4WD
86531	2005-2013	2.5 COIL OVER BRACKETS W/ SPACERS (TALL)	27	12"	4WD
SINGLE REAR SHOCK STOCK LOCATION					
C2014-625R	2005-2012	FTS 2.0 REMOTE RESERVOIR 14" TRAVEL CHROME FINISH (STOCK REAR LOCATION)	29,30	12"	4WD
B2014-625R	2005-2012	FTS 2.0 REMOTE RESERVOIR 14" TRAVEL BLACK FINISH (STOCK REAR LOCATION)	29,31	12"	4WD
BILLET SHOCK CLAMPS					
C2020	2007-2013	FTS 2.0 BILLET SHOCK CLAMPS CHROME FINISH	38	12"	4WD
B2020	2007-2013	FTS 2.0 BILLET SHOCK CLAMPS BLACK FINISH	38	12"	4WD
ACCESSORIES					
86523	2005-2010	FRONT / REAR STEEL BRAIDED BRAKE LINE KIT (SINGLE REAR)	79	12"	4WD
87528	2011-2013	FRONT / REAR STEEL BRAIDED BRAKE LINE KIT (DUAL REAR)	79	12"	4WD
87546	2005-2012	DOUBLE FRONT STEERING STABILIZER KIT W/ BASIC HYDRAULIC STABILIZERS	56	ALL	4WD
87547	2005-2012	DOUBLE FRONT STEERING STABILIZER KIT W/ FTS 2.0 CHROME STABILIZERS	30,56	ALL	4WD
87548	2005-2012	DOUBLE FRONT STEERING STABILIZER KIT W/ FTS 2.0 BLACK STABILIZERS	31,56	ALL	4WD
28974	2005-2012	BOLT ON TRACTION BAR KIT 74" SHORT BED	27,56,58	12"	4WD
28980	2005-2012	BOLT ON TRACTION BAR KIT 80" LONG BED	27,56,58	12"	4WD
86700	2005-2010	TRANSFER CASE RECLOCKING RING	65	12"	4WD
86705	2005-2013	CROSSOVER STEERING KNUCKLE KIT	48,49	12"	4WD
86708	2005-2013	CROSSOVER STEERING TRACK BAR KIT	50	12"	4WD



14" 4WD 2008-2013 FORD F-250 / F-350
LONG ARM KIT Part #87712

14" 2005 - 2013 FORD F-250 / F-350



PART #	YEAR	TITLE	FOOTERNOTES	LIFT SIZE	2WD / 4WD
14" 2008-2012 FORD F250/350 4WD					
86712	2005-2007	2005-2007 FORD F250/350 14" LONG ARM KIT W/ REAR SPRINGS W/ CROSSOVER	59,80	14"	4WD
87712	2008-2013	2008-2013 FORD F250/350 14" LONG ARM KIT W/ REAR SPRINGS W/ CROSSOVER	59,80	14"	4WD
SINGLE FRONT SHOCK STOCK LOCATION					
C2014-625RS	2005-2012	FTS 2.0 REMOTE RESERVOIR 14" TRAVEL CHROME FINISH (STOCK FRONT LOCATION)	29,30	14"	4WD
B2014-625RS	2005-2012	FTS 2.0 REMOTE RESERVOIR 14" TRAVEL BLACK FINISH (STOCK FRONT LOCATION)	29,31	14"	4WD
2.5 COIL OVER KIT W/ COILS					
E2512-875C	2005-2012	FTS 2.5" X 12" EMULSION COILOVER W/ COILS	10,33	14"	4WD
R2512-875C	2005-2012	FTS 2.5" X 12" REMOTE RESERVOIR COILOVER W/ COILS	10,33,57	14"	4WD
86530	2005-2013	2.5 COIL OVER BRACKETS W/ SPACERS (SHORT)	27	14"	4WD
SINGLE REAR SHOCK STOCK LOCATION					
C2014-625R	2005-2012	FTS 2.0 REMOTE RESERVOIR 14" TRAVEL CHROME FINISH (STOCK REAR LOCATION)	29,30	14"	4WD
B2014-625R	2005-2012	FTS 2.0 REMOTE RESERVOIR 14" TRAVEL BLACK FINISH (STOCK REAR LOCATION)	29,31	14"	4WD
BILLET SHOCK CLAMPS					
C2020	2007-2013	FTS 2.0 BILLET SHOCK CLAMPS CHROME FINISH	38	14"	4WD
B2020	2007-2013	FTS 2.0 BILLET SHOCK CLAMPS BLACK FINISH	38	14"	4WD
ACCESSORIES					
86723	2005-2010	FRONT / REAR STEEL BRAIDED BRAKE LINE KIT (SINGLE REAR)	79	14"	4WD
87728	2011-2013	FRONT / REAR STEEL BRAIDED BRAKE LINE KIT (DUAL REAR)	79	14"	4WD
87546	2005-2012	DOUBLE FRONT STEERING STABILIZER KIT W/ BASIC HYDRAULIC STABILIZER	56	ALL	4WD
87547	2005-2012	DOUBLE FRONT STEERING STABILIZER KIT W/ FTS 2.0 CHROME STABILIZER	30,56	ALL	4WD
87548	2005-2012	DOUBLE FRONT STEERING STABILIZER KIT W/ FTS 2.0 BLACK STABILIZER	31,56	ALL	4WD
28974	2005-2012	BOLT ON TRACTION BAR KIT 74" SHORT BED	27,56,58	14"	4WD
28980	2005-2012	BOLT ON TRACTION BAR KIT 80" LONG BED	27,56,58	14"	4WD
86700	2005-2010	TRANSFER CASE RECLOCKING RING	65	14"	4WD
86705	2005-2013	CROSSOVER STEERING KNUCKLE KIT	48,49	14"	4WD
86708	2005-2013	CROSSOVER STEERING TRACK BAR KIT	50	14"	4WD

4-24" 1999 - 2004 FORD F-250 / F-350 / EXCURSION

Computer engineered leaf technology for great ride quality
 Leaf springs individually load tested for quality assurance and long life
 OEM bushings for exact fit and quiet smooth ride
 Optional adjustable track bar with 1.1/4" heim joints for strength in the most conditions
 Crossover steering available for lifts 10" and up improves durability and steering stability
 Shackle and hanger kits provide 3.5", 5", or 8" of front lift with an easy to install kit
 Optional FTS transference re-locking ring kit allows stock front driveshaft geometry on lifts up to 24"



3.5" Hanger Shackle Kit Max Recommended Tire Size 33" Max Recommended Wheel Width 10"
 5" Hanger Shackle Kit Max Recommended Tire Size 35" Max Recommended Wheel Width 10"
 8" Hanger Shackle Kit Max Recommended Tire Size 37" Max Recommended Wheel Width 10"
 4" Leaf Springs Max Recommended Tire Size 33" Max Recommended Wheel Width 10"
 6" Leaf Springs Max Recommended Tire Size 35" Max Recommended Wheel Width 10"
 8" Leaf Springs Max Recommended Tire Size 37" Max Recommended Wheel Width 10"
 10" Leaf Springs Max Recommended Tire Size 38" Max Recommended Wheel Width 10"
 12" Leaf Springs Max Recommended Tire Size 40" Max Recommended Wheel Width 10"
 14" Leaf Springs Max Recommended Tire Size 42" Max Recommended Wheel Width 10"
 16" Leaf Springs Max Recommended Tire Size 44" Max Recommended Wheel Width 10"
 18" Leaf Springs Max Recommended Tire Size 46" Max Recommended Wheel Width 10"
 20" Leaf Springs Max Recommended Tire Size 49" Max Recommended Wheel Width 10"
 22" Leaf Springs Max Recommended Tire Size 49" Max Recommended Wheel Width 10"
 24" Leaf Springs Max Recommended Tire Size 52" Max Recommended Wheel Width 10"

PART #	YEAR	TITLE	LIFT SIZE	2WD / 4WD
4" 1999-2004 FORD F250 / F350				
78001	1999-2004	4" Basic Kit W/ Rear Blocks	4"	4WD
SDFD4	1999-2004	Front Springs (Pair)	4"	4WD
SDRD4	1999-2004	Rear Springs (Pair)	4"	4WD
6" 1999-2004 FORD F250 / F350				
78101	1999-2004	6" Basic Kit W/ Rear Blocks	6"	4WD
SDFD6	1999-2004	Front Springs (Pair)	6"	4WD
SDRD7	1999-2004	Rear Springs (Pair)	6"	4WD
8" 1999-2004 FORD F250 / F350				
78201	1999-2004	8" Basic Kit W/ Rear Blocks	8"	4WD
SDFD8	1999-2004	Front Springs (Pair)	8"	4WD
SDRD9	1999-2004	Rear Springs (Pair)	8"	4WD
Front and Rear Springs & Hangers				
SDFD4	1999-2004	4" Front Springs (Pair)	4"	4WD
SDRD4	1999-2004	4" Rear Springs (Pair)	4"	4WD
SDFD6	1999-2004	6" Front Springs (Pair)	6"	4WD
SDRD6	1999-2004	6" Rear Springs (Pair)	6"	4WD
SDFD8	1999-2004	8" Front Springs (Pair)	8"	4WD
SDRD8	1999-2004	8" Rear Springs (Pair)	8"	4WD
SDFD10	1999-2004	10" Front Springs (Pair)	10"	4WD
SDRD10	1999-2004	10" Rear Springs (Pair)	10"	4WD
SDFD12	1999-2004	12" Front Springs (Pair)	12"	4WD
SDRD12	1999-2004	12" Rear Springs (Pair)	12"	4WD
SDFD14	1999-2004	14" Front Springs (Pair)	14"	4WD
SDRD14	1999-2004	14" Rear Springs (Pair)	14"	4WD
SDFD16	1999-2004	16" Front Springs (Pair)	16"	4WD
SDRD16	1999-2004	16" Rear Springs (Pair)	16"	4WD
SDFD18	1999-2004	18" Front Springs (Pair)	18"	4WD
SDRD18	1999-2004	18" Rear Springs (Pair)	18"	4WD
SDFD20	1999-2004	20" Front Springs (Pair)	20"	4WD
SDRD20	1999-2004	20" Rear Springs (Pair)	20"	4WD
SDFD22	1999-2004	22" Front Springs (Pair)	22"	4WD
SDRD22	1999-2004	22" Rear Springs (Pair)	22"	4WD
SDFD24	1999-2004	24" Front Springs (Pair)	24"	4WD
SDRD24	1999-2004	24" Rear Springs (Pair)	24"	4WD
79101	1999-2004	3.5" Hanger Kit	3.5"	4WD
79201	1999-2004	5.5" Hanger Kit	5.5"	4WD
79301	1999-2004	8" Hanger Kit	8"	4WD

PART #	YEAR	TITLE	LIFT SIZE	2WD / 4WD
Accessories				
79100	1999-2000	CROSS OVER STEERING KIT	10"-24"	4WD
79102	1999-2000	CROSS OVER TRACK BAR KIT	10"-24"	4WD
79111	2001-2004	CROSS OVER STEERING KIT	10"-24"	4WD
79112	2001-2004	CROSS OVER TRACK BAR KIT	10"-24"	4WD
79130	1999-2004	TRANSFERCASE RELOCKING RING	8"-24"	4WD
79247	1999-2004	TRACTION BAR KIT 65"	4"-8"	4WD
79248	1999-2004	TRACTION BAR KIT 75"	4"-8"	4WD
79249	1999-2004	TRACTION BAR KIT 70"	10"-14"	4WD
79250	1999-2004	TRACTION BAR KIT 80"	10"-14"	4WD
79250	1999-2004	TRACTION BAR KIT 80"	16"-24"	4WD
79251	1999-2004	TRACTION BAR KIT 85"	16"-24"	4WD
79240	1999-2004	DOUBLE FORNT SHOCK HOOPS	4"-8"	4WD
79049	1999-2004	DOUBLE REAR SOCK BKT KIT	4"-8"	4WD
79246	1999-2004	DOUBLE STEERING STABILIZER KIT	ALL	4WD
79271	1999-2004	2" REAR DRIVE LINE SPACER	12"-24"	4WD
79022	1999-2000	STEEL BRAIDED BRAKE LINES 4" to 6" lift	4"-6"	4WD
79026	2001-2004	STEEL BRAIDED BRAKE LINES 4" to 6" lift	4"-6"	4WD
79122	1999-2000	STEEL BRAIDED BRAKE LINES 8" to 12" lift	8"-12"	4WD
79126	2001-2004	STEEL BRAIDED BRAKE LINES 8" to 12" lift	8"-12"	4WD
79222	1999-2000	STEEL BRAIDED BRAKE LINES 14" to 18" lift	14"-18"	4WD
79226	2001-2004	STEEL BRAIDED BRAKE LINES 14" to 18" lift	14"-18"	4WD
79322	1999-2000	STEEL BRAIDED BRAKE LINES 20" to 24" lift	20"-24"	4WD
79326	2001-2004	STEEL BRAIDED BRAKE LINES 20" to 24" lift	20"-24"	4WD
79140	1999-2004	2" CARRIER BEARING SPACER		4WD
79141	1999-2005	2.25" CARRIER BEARING SPACER		4WD
79142	1999-2007	2.5" CARRIER BEARING SPACER		4WD
79143	1999-2008	2.75" CARRIER BEARING SPACER		4WD
79144	1999-2009	3" CARRIER BEARING SPACER		4WD
79145	1999-2010	3.25" CARRIER BEARING SPACER		4WD
79146	1999-2011	3.5" CARRIER BEARING SPACER		4WD
79147	1999-2012	3.75" CARRIER BEARING SPACER		4WD
79148	1999-2013	4" CARRIER BEARING SPACER		4WD
79149	1999-2004	4.5" CARRIER BEARING SPACER		4WD
79600	1999-2004	SWAY BAR END LINKS (HEIMS) 4" lift	4"	4WD
79601	1999-2004	SWAY BAR END LINKS (HEIMS) 6" lift	6"	4WD
79602	1999-2004	SWAY BAR END LINKS (HEIMS) 8" lift	8"	4WD
79603	1999-2004	SWAY BAR END LINKS (HEIMS) 10" lift	10"	4WD
79604	1999-2004	SWAY BAR END LINKS (HEIMS) 12" lift	12"	4WD
79605	1999-2004	SWAY BAR END LINKS (HEIMS) 14" lift	14"	4WD
79607	1999-2004	SWAY BAR END LINKS (HEIMS) 16" lift	16"	4WD
79608	1999-2004	SWAY BAR END LINKS (HEIMS) 18" lift	18"	4WD
79609	1999-2004	SWAY BAR END LINKS (HEIMS) 20" lift	20"	4WD
79610	1999-2004	SWAY BAR END LINKS (HEIMS) 22" lift	22"	4WD
79611	1999-2004	SWAY BAR END LINKS (HEIMS) 24" lift	24"	4WD
79612	1999-2004	SWAY BAR END LINKS (HEIMS) 26" lift	26"	4WD



6" 2004 - 2013 FORD F150

2004-2013 FORD F150

100% bolt on Spindle Kit that does not extend track width
 Impact struts to distribute suspension impact throughout the frame
 Structural crossmembers constructed of 1/4" thick steel for superior strength
 Heavy duty semi gloss black powder for long life and great looks
 Offset rear lift block keeps the rear axle centered
 Utilizes ductile iron steering knuckle for stock alignment and superior driveability both on and offroad



6" 4wd kit Max Recommended Tire Size 35" Max Recommended Wheel Width 10"
 8" 4wd kit Max Recommended Tire Size 37" Max Recommended Wheel Width 10"
 6" 2wd kit Max Recommended Tire Size 33" Max Recommended Wheel Width 10"
 8" 2wd kit Max Recommended Tire Size 35" Max Recommended Wheel Width 10"

Basic 2wd/4wd 6" kit includes:
 6" Front Box Kit
 3" Rear Block Kit
 LH / RH Steering Knuckles
 Basic 2wd/4wd 8" kit includes:
 8" Front Box Kit
 5" Rear Block Kit
 LH / RH Steering Knuckles
 Upper Control Arms
 Shocks Sold Separately.
 Please see options below

PART #	YEAR	TITLE	FOOTNOTES	LIFT SIZE	2WD / 4WD
6" 2004-2008 FORD F150 2WD					
74001	2004-2008	FORD F150 2WD BASIC KIT	2, 19	6"	2WD
74011	2004-2008	FORD F150 2WD KIT W/ 2.5 COILOVERS	2, 19	6"	2WD
C2011-625R	2004-2008	FTS 2.0 REMOTE RESERVOIR 11" TRAVEL CHROME FINISH (STOCK REAR LOCATION)	29, 30	6"	2WD
B2011-625R	2004-2008	FTS 2.0 REMOTE RESERVOIR 11" TRAVEL BLACK FINISH (STOCK REAR LOCATION)	29, 31	6"	2WD
74050	2008-2008	FTS 2.5 EMULSION COILOVER COMPLETE WITH COILS / MOUNTING BRACKETS	10, 33	6"	2WD
6" 2004-2008 FORD F150 4WD					
74002	2004-2008	FORD F150 4WD BASIC KIT	2, 19, 53	6"	4WD
74012	2004-2008	FORD F150 4WD KIT W/ 2.5 COILOVERS	2, 19, 53	6"	4WD
C2011-625R	2004-2008	FTS 2.0 REMOTE RESERVOIR 11" TRAVEL CHROME FINISH (STOCK REAR LOCATION)	29, 30	6"	4WD
B2011-625R	2004-2008	FTS 2.0 REMOTE RESERVOIR 11" TRAVEL BLACK FINISH (STOCK REAR LOCATION)	29, 31	6"	4WD
74050	2004-2008	FTS 2.5 EMULSION COILOVER COMPLETE WITH COILS / MOUNTING BRACKETS	10, 33	6"	4WD
6" 2009-2013 FORD F150 2WD					
75004	2009-2013	FORD F150 2WD BASIC KIT	2, 19	6"	2WD
75014	2009-2013	FORD F150 2WD KIT W/ 2.5 COILOVERS	2, 19	6"	2WD
C2011-625R	2009-2013	FTS 2.0 REMOTE RESERVOIR 11" TRAVEL CHROME FINISH (STOCK REAR LOCATION)	29, 30	6"	2WD
B2011-625R	2009-2013	FTS 2.0 REMOTE RESERVOIR 11" TRAVEL BLACK FINISH (STOCK REAR LOCATION)	29, 31	6"	2WD
75050	2009-2013	FTS 2.5 EMULSION COILOVER COMPLETE WITH COILS / MOUNTING BRACKETS	10, 33	8"	2WD
6" 2009-2013 FORD F150 4WD					
75005	2009-2013	FORD F150 4WD BASIC KIT	2, 19	6"	4WD
75015	2009-2013	FORD F150 4WD KIT W/ 2.5 COILOVERS	2, 19	6"	4WD
C2011-625R	2009-2013	FTS 2.0 REMOTE RESERVOIR 11" TRAVEL CHROME FINISH (STOCK REAR LOCATION)	29, 30	6"	4WD
B2011-625R	2009-2013	FTS 2.0 REMOTE RESERVOIR 11" TRAVEL BLACK FINISH (STOCK REAR LOCATION)	29, 31	6"	4WD
75050	2009-2013	FTS 2.5 EMULSION COILOVER COMPLETE WITH COILS / MOUNTING BRACKETS	10, 33	6"	4WD

6" 4WD 2004-2008 FORD F-150
 Part #74002



6" 2WD 2009-2013 FORD F-150
 Part #75004

8" 2004 - 2013 FORD F150

8" 4WD 2004-2008 FORD F-150
 Part #71002



8" 2WD 2009-2013 FORD F-150
 Part #72001

PART #	YEAR	TITLE	FOOTNOTES	LIFT SIZE	2WD / 4WD
2WD					
8" 2004-2008 FORD F150 2WD					
71001	2004-2008	FORD F150 2WD BASIC KIT	2, 19	8"	2WD
71011	2004-2008	FORD F150 2WD KIT W/ 2.5 COILOVERS	2, 19	8"	2WD
C2012-625R	2004-2008	FTS 2.0 REMOTE RESERVOIR 12" TRAVEL CHROME FINISH (STOCK REAR LOCATION)	29, 30	8"	2WD
B2012-625R	2004-2008	FTS 2.0 REMOTE RESERVOIR 12" TRAVEL BLACK FINISH (STOCK REAR LOCATION)	29, 31	8"	2WD
71050	2004-2008	FTS 2.5 EMULSION COILOVER COMPLETE WITH COILS / MOUNTING BRACKETS	10, 33	8"	2WD
4WD					
8" 2004-2008 FORD F150 4WD					
71002	2004-2008	FORD F150 4WD BASIC KIT	2, 19, 53	8"	4WD
71012	2004-2008	FORD F150 4WD KIT W/ 2.5 COILOVERS	2, 19, 53	8"	4WD
C2012-625R	2004-2008	FTS 2.0 REMOTE RESERVOIR 12" TRAVEL CHROME FINISH (SINGLE REAR SHOCK)	29, 30	8"	4WD
B2012-625R	2004-2008	FTS 2.0 REMOTE RESERVOIR 12" TRAVEL BLACK FINISH (SINGLE REAR SHOCK)	29, 31	8"	4WD
71050	2004-2008	FTS 2.5 EMULSION COILOVER COMPLETE WITH COILS / MOUNTING BRACKETS	10, 33	8"	4WD
2WD					
8" 2009-2013 FORD F150 2WD					
72001	2009-2013	FORD F150 2WD BASIC KIT	2, 19, 53	8"	2WD
72011	2009-2013	FORD F150 2WD KIT W/ 2.5 COILOVERS	2, 19, 53	8"	2WD
C2012-625R	2009-2013	FTS 2.0 REMOTE RESERVOIR 12" TRAVEL CHROME FINISH (STOCK REAR LOCATION)	29, 30	8"	2WD
B2012-625R	2009-2013	FTS 2.0 REMOTE RESERVOIR 12" TRAVEL BLACK FINISH (STOCK REAR LOCATION)	29, 31	8"	2WD
72050	2009-2013	FTS 2.5 EMULSION COILOVER COMPLETE WITH COILS / MOUNTING BRACKETS	10, 33	8"	2WD
4WD					
8" 2009-2013 FORD F150 4WD					
72002	2009-2013	FORD F150 4WD BASIC KIT	2, 19, 53	8"	4WD
72012	2009-2013	FORD F150 4WD KIT W/ 2.5 COILOVERS	2, 19, 53	8"	4WD
C2012-625R	2009-2013	FTS 2.0 REMOTE RESERVOIR 12" TRAVEL CHROME FINISH (STOCK REAR LOCATION)	29, 30	8"	4WD
B2012-625R	2009-2013	FTS 2.0 REMOTE RESERVOIR 12" TRAVEL BLACK FINISH (STOCK REAR LOCATION)	29, 31	8"	4WD
72050	2009-2013	FTS 2.5 EMULSION COILOVER COMPLETE WITH COILS / MOUNTING BRACKETS	10, 33	8"	4WD
BILLET SHOCK CLAMPS					
C2020	2004-2013	FTS 2.0 BILLET SHOCK CLAMPS CHROME FINISH	38	ALL	4WD
B2020	2004-2013	FTS 2.0 BILLET SHOCK CLAMPS BLACK FINISH	38	ALL	4WD
ACCESSORIES					
74022	2004-2008	FRONT / REAR STEEL BRAIDED BRAKE LINE KIT (SINGLE REAR)	79	6"/8"	2WD/4WD
75022	2009-2013	FRONT / REAR STEEL BRAIDED BRAKE LINE KIT (DUAL REAR)	79	6"/8"	2WD / 4WD
75041	2004-2013	BALL JOINT UPPER A ARMS	41	6"/8"	2WD/4WD
74050	2004-2008	FTS 2.5 EMULSION COILOVER COMPLETE WITH COILS / MOUNTING BRACKETS	10, 33	6"	2WD/4WD
71050	2004-2008	FTS 2.5 EMULSION COILOVER COMPLETE WITH COILS / MOUNTING BRACKETS	10, 33	8"	2WD/4WD
75050	2009-2013	FTS 2.5 EMULSION COILOVER COMPLETE WITH COILS / MOUNTING BRACKETS	10, 33	6"	2WD/4WD
72050	2009-2013	FTS 2.5 EMULSION COILOVER COMPLETE WITH COILS / MOUNTING BRACKETS	10, 33	8"	2WD/4WD
TRACTION BARS					
17963	2004-2013	BOLT ON TRACTION BAR KIT 63" (SHORT BED)	27, 56, 58	6"/8"	2WD / 4WD
17968	2004-2013	BOLT ON TRACTION BAR KIT 68" (LONG BED)	27, 56, 58	6"/8"	2WD / 4WD

6" 2007 - 2013 TOYOTA TUNDRA

100% bolt on
 Utilizes ductile iron steering knuckle for stock alignment and superior driveability both on and offroad
 Impact struts to distribute suspension impact throughout the frame
 Structural crossmembers constructed of 1/4" thick steel for superior strength
 Does not extend track width
 Heavy duty semi gloss black powder for long life and great looks
 Rear block kit with no add a leaf for fast installation and factory ride



Basic 6" kit includes:
 6" Front Box Kit
 3" Rear Block Kit
 LH / RH Steering Knuckles
Basic 8" kit includes:
 8" Front Box Kit
 5" Rear Block Kit
 LH / RH Steering Knuckles
 Shocks Sold Separately.
 Please see options below

6" Kit Max Recommended Tire Size 35" Max Recommended Wheel Width 10"
 8" Kit Max Recommended Tire Size 37" Max Recommended Wheel Width 10"

6" 4WD 2007-2013 TOYOTA TUNDRA
Part #86408



8" 4WD 2007-2013 TOYOTA TUNDRA
W/ COILOVERS Part #86419



PART #	YEAR	TITLE	FOOTNOTES	LIFT SIZE	2WD / 4WD
6" 2007-2013 TOYOTA TUNDRA					
B6408	2007-2013	2007-2013 TOYOTA TUNDRA 6" BASIC KIT		6"	4WD
B6418	2007-2013	2007-2013 TOYOTA TUNDRA 6" BASIC KIT W/ COILOVERS		6"	4WD
SINGLE REAR SHOCK STOCK LOCATION					
B2012-625RS	2007-2013	FTS 2.0 REMOTE RESERVOIR 12" TRAVEL CHROME FINISH (STOCK REAR LOCATION)	29, 30, 54	6"	4WD
C2012-625RS	2007-2013	FTS 2.0 REMOTE RESERVOIR 12" TRAVEL BLACK FINISH (STOCK REAR LOCATION)	29, 31, 54	6"	4WD
FRONT COIL OVER SHOCKS COMPLETE					
C8470-7E	2007-2013	FTS 2.5 EMULSION COILOVER SHOCK COMPLETE W/ COILS, MOUNTING BRACKETS	10, 33	6"	4WD
C8470-7R	2007-2013	FTS 2.5 REMOTE RESERVIOR COILOVER SHOCK COMPLETE W/ COILS, MOUNTING BRACKETS	10, 33, 57	6"	4WD

8" 2007 - 2013 TOYOTA TUNDRA

PART #	YEAR	TITLE	FOOTNOTES	LIFT SIZE	2WD / 4WD
8" 2007-2013 TOYOTA TUNDRA					
B6409	2007-2013	2007-2013 TOYOTA TUNDRA 8" BASIC KIT		8"	4WD
B6419	2007-2013	2007-2013 TOYOTA TUNDRA 8" BASIC KIT W/ COILOVERS		8"	4WD
SINGLE REAR SHOCK STOCK LOCATION					
B2012-625RS	2007-2013	FTS 2.0 REMOTE RESERVOIR 12" TRAVEL CHROME FINISH (STOCK REAR LOCATION)	29, 30, 54	8"	4WD
C2012-625RS	2007-2013	FTS 2.0 REMOTE RESERVOIR 12" TRAVEL BLACK FINISH (STOCK REAR LOCATION)	29, 31, 54	8"	4WD
FRONT COIL OVER SHOCKS COMPLETE					
C8470-7E	2007-2013	FTS 2.5 EMULSION COILOVER SHOCK COMPLETE W/ COILS, MOUNTING BRACKETS	10, 33	8"	4WD
C8470-7R	2007-2013	FTS 2.5 REMOTE RESERVIOR COILOVER SHOCK COMPLETE W/ COILS, MOUNTING BRACKETS	10, 33, 57	8"	4WD

7" 2004 - 2012 NISSAN TITAN

100% bolt on
 Utilizes ductile iron steering knuckle for stock alignment and superior driveability both on and offroad
 Impact struts to distribute suspension impact throughout the frame
 Structural crossmembers constructed of 1/4" thick steel for superior strength
 Does not extend track width
 Heavy duty semi gloss black powder for long life and great looks
 Rear block kit with no add a leaf for fast installation and factory ride



Basic 7" kit includes:
 7" Front Box Kit
 4" Rear Block Kit
Basic 15" kit includes:
 15" Front Box Kit
 15" Rear Springs
 2.5" FTS Front Coilovers
 Upper control arms

7" Kit Max Recommended Tire Size 35" Max Recommended Wheel Width 10"
 15" Kit Max Recommended Tire Size 42" Max Recommended Wheel Width 10"

7" 4WD 2004-2012 NISSAN TITAN
Part #86409



7" 4WD 2004-2012 NISSAN TITAN
W/ COILOVERS Part #88408



PART #	YEAR	TITLE	FOOTNOTES	LIFT SIZE	2WD / 4WD
7" 2004-2012 NISSAN TITAN					
B8405	2004-2012	2004-2012 NISSAN TITAN 7" BASIC KIT		7"	2WD
B8407	2004-2012	2004-2012 NISSAN TITAN 7" BASIC KIT W/ COILOVERS		7"	2WD
B8406	2004-2012	2004-2012 NISSAN TITAN 7" BASIC KIT		7"	4WD
B8408	2004-2012	2004-2012 NISSAN TITAN 7" BASIC KIT W/ COILOVERS		7"	4WD
FRONT COIL OVER SHOCKS COMPLETE					
C8470-7E	2004-2012	FTS 2.5 EMULSION COILOVER SHOCK COMPLETE W/ COILS, MOUNTING BRACKETS	10, 33	7"	4WD
C8470-7R	2004-2012	FTS 2.5 REMOTE RESERVIOR COILOVER SHOCK COMPLETE W/ COILS, MOUNTING BRACKETS	10, 33, 57	7"	4WD

15" 2004 - 2012 NISSAN TITAN

PART #	YEAR	TITLE	FOOTNOTES	LIFT SIZE	2WD / 4WD
15" 2004-2012 NISSAN TITAN					
B8607	2004-2012	2004-2012 NISSAN TITAN 15" W/ COILOVERS		15"	2WD
B8608	2004-2012	2004-2012 NISSAN TITAN 15" W/ COILOVERS		15"	4WD

See website for more details

FOOTERNOTES

NUMBER	FOOTERNOTES
1	KIT INCLUDES FRONT BOX KIT, REAR SPRINGS, FRONT / REAR BAKE BRAKE LINES, CV FRONT DRIVE LINE
2	KIT INCLUDES FRONT BOX KIT, REAR BLOCK KIT AND HARDWARE
3	NON DUALY MODELS ONLY
4	KIT INCLUDES FRONT BOX KIT, REAR KIT AND HARDWARE
5	KIT INCLUDES FRONT BOX KIT, REAR SPRINGS, FRONT / REAR BAKE BRAKE LINES
6	INCREASES FRONT TRACK WIDTH 1" ON BOTH SIDES
7	KIT INCLUDES FRONT BOX KIT, REAR KIT , FRONT / REAR BAKE BRAKE LINES, CV FRONT DRIVE LINE 4WD
8	INCREASES FRONT TRACK WIDTH 1/2" ON EACH SIDE.
9	KIT INCLUDES FRONT BOX KIT, REAR KIT, FRONT / REAR BAKE BRAKE LINES, 2WD
10	NICKEL PLATED BODY EARLY 2000 MODELS MAY REQUIRE 1999 BOX KITS. IF FACTORY TRANSMISSON CROSSMEMBER IS STRAIGHT USE 2000-06 BOX KITS. IF FACTORY
11	TRANSMISSION IS CURVED IN A S-SHAPE USE 1999 BOX KIT.
12	MAY REQUIRE EXHAUST MODIFICATION
13	SHOCK MAY REQUIRE SMALL BUSHING KIT (PART# B500)
14	SHOCK MAY REQUIRE LARGE BUSHING KIT (PART# B916)
15	MAY REQUIRE CARRIER BEARING SPACER KIT
16	UTILIZES STOCK REAR SHOCKS
17	ONLY WORK WITH 2.5 COILOVERS
18	THE INSTALLATION OF THIS KIT REQUIRES WELDING
19	REQUIRE ALIGNMENT AFTER INSTALLATION
20	KIT INCLUDES FRONT BOX KIT, REAR SPRINGS, FRONT / REAR BAKE BRAKE LINES, REAR BLOCK KIT, CV FRONT DRIVE LINE, REAR DRIVE LINE SPACER
21	KIT INCLUDES FRONT BOX KIT, REAR SPRINGS, FRONT / REAR BAKE BRAKE LINES, REAR BLOCK KIT, REAR DRIVE LINE SPACER
22	KIT INCLUDES FRONT BOX KIT, REAR SPRINGS, FRONT / REAR BAKE BRAKE LINES, REAR BLOCK KIT, REAR DRIVE LINE SPACER
23	REQUIRES 2 JAW PULLER
24	USE NEVER SIEZE ON THREADS
25	TORQUE U BOLTS TO STANDARD BOLT SPECS
26	SHOCK MAY REQUIRE LIGHTER VALVING FOR STANDARD CAB TRUCK
27	DRILLING REQUIRED
28	KIT INCLUDES FRONT BOX KIT, REAR KIT, FRONT / REAR BAKE BRAKE LINES, CV FRONT DRIVE LINE REAR DRIVE LINE SPACER
29	KIT INCLUDES FRONT BOX KIT, REAR KIT, FRONT / REAR BAKE BRAKE LINES, CV FRONT DRIVE LINE REAR DRIVE LINE SPACER
30	REQUIRES BILLET SHOCK CLAMP TO HOLD RESERVIOR
31	SHOCK BODYS CHROME W/ ANODIZED BLACK ENDS
32	SHOCK BODY POWDER COATED BLACK W/ ANODIZED BALCK ENDS
33	MAY REQUIRE CV REAR DRIVE SHAFT ON TAHOE, AVALANCHE DENALI ESECLADE
34	SPANNER WRENCH REQUIRED
35	DRIVE LINE NEED TO BE GREASED EVERY 3000 MILES
36	KIT INCLUDES FRONT BOX KIT, REAR KIT, FRONT / REAR BAKE BRAKE LINES, REAR DRIVE LINE SPACER
37	ALL WHEEL DRIVE VEHICLE REQUIRE A CV FRONT DRIVE SHAFT
38	DO NOT OVER TIGHTEN CLAMP , WILL DISTORT SHOCK BODY
39	CAN RUN HOOPS WITH 1 OR 2 SHOCKS MOUNTED TO IT
40	ARMS COME UNASSEMBLED , WILL NEED TO PRESS IN UNI BALL
41	ARMS COME UNASSEMBLED , WILL NEED TO PRESS BUSHINGS
42	SOME MODELS MAY NOT SIT LEVEL AFTER INSTALL.
43	WILL WORK WITH OR WITH OUT AUTO RIDE
44	SILICONE REQUIRED
45	KIT INCLUDES FRONT BOX KIT, REAR SPRINGS, FRONT / REAR BAKE BRAKE LINES, CV FRONT DRIVE LINE REAR DRIVE LINE SPACER
46	KIT INCLUDES FRONT BOX KIT, REAR BLOCK KIT AND HARDWARE REAR DRIVE LINE SPACER
47	TRANSMISSION BRACKET MAY BE REQUIRED
48	REQUIRE TO PRESS BALL JOINT IN KNUCKLE
49	REQUIRE CROSSOVER TRACK BAR KIT
50	REQUIRE USE WITH CROSSOVER STEERING KNUCKLE KIT
51	WILL NOT FIT WITH CROSSOVER STEERING
52	REQUIRES TORSION BAR LOAD AND UNLOAD TOOL
54	SHOCK NEED TO BE PRESSUREIZED WITH NITROGEN AFTER INSTALLED
55	NEED TO REMOVE GAS TANK TO INSTALL SPRINGS
56	BOLT ON BRACKET KIT
57	TORQUE U BOLTS TO PROPER SPECS
58	MAY REQUIRE LONGER U BOLTS
59	FRONT DRIVE SHAFT MODIFICATION MAY BE REQUIRED TO CLEAR EXHAUST ON GAS MOTOR
60	CHECK CAP DIAMETER / WITH OF U JOINT BEFOR INSTALLING
62	REQUIRE DISASSEMBLY OF FRONT STRUTS
65	REQUIERS REMOVING TRANSFER CASE FOR INSTALLATION
68	REPLACES STOCK TRACK BAR
69	REPLACE STOCK TRAILING ARM
72	REQUIRES YOU TO DRILL SPINDLE TO 3/4 " FOR UNIBALL UPPER A ARM
79	REQUIRED TO BLEED BRAKE AFTER INSTALLATION
80	REAR LEAF SPRINGS MAY REDUCE LOAD CARRYING CAPACITY
81	REQUIRED RELOCATRING SWAY BAR BEHIND FRONT AXLE
82	CUTTING REQUIRED
90	WILL NOT WORK WITH NON TORSION BAR DROP KIT
97	BASIC KIT REQUIRE SHOCK BRACKET IF EQUIPT WITH AUTO RIDE SHOCKS
98	BASIC KIT INCLUDES REAR SHOCK BRACKETS
99	COMPLETE KIT JUST REQUIRES SHOCKS FOR NON AUTO RIDE SUSPENSION

2.0 SHOCKS

FTS 2.0 Performance Series Shocks delivers performance in a bolt-on package. Quality design and innovative construction provide superior suspension control and durability. Shock travel ranges for 4.5" to 16". All 2.0" shocks come standard with nickel plated cylinders, high strength 7/8" steel shafts that will not chip or rust & are fully rebuildable and revalve. Combine these new technologies with a competitive price for a winning combination.

2.0 SMOOTH BODY EMULSION 5/8 SHAFT					
TRAVEL	BLACK FINISH	CHROME FINISH	EXTENDED LENGTH	COLLAPSED LENGTH	ENDS
5"	B2050-625E	C2050-625E	15.90"	10.90"	LOOP / LOOP
6.5"	B2065-625E	C2065-625E	19.00"	12.50"	LOOP / LOOP
8.5"	B2085-625E	C2085-625E	23.00"	14.50"	LOOP / LOOP
10"	B2010-625E	C2010-625E	26.25"	16.25"	LOOP / LOOP
11"	B2011-625E	C2011-625E	28.25"	17.25"	LOOP / LOOP
12"	B2012-625E	C2012-625E	31.25"	19.25"	LOOP / LOOP
14"	B2014-625E	C2014-625E	35.25"	21.25"	LOOP / LOOP
16"	B2016-625E	C2016-625E	39.25"	23.25"	LOOP / LOOP

2.0 SMOOTH BODY REMOTE RESEVOIR 5/8 SHAFT					
TRAVEL	BLACK FINISH	CHROME FINISH	EXTENDED LENGTH	COLLAPSED LENGTH	ENDS
5"	B2050-625R	C2050-625R	15.90"	10.90"	LOOP / LOOP
6.5"	B2065-625R	C2065-625R	19.00"	12.50"	LOOP / LOOP
8.5"	B2085-625R	C2085-625R	23.00"	14.50"	LOOP / LOOP
10"	B2010-625R	C2010-625R	26.25"	16.25"	LOOP / LOOP
11"	B2011-625R	C2011-625R	28.25"	17.25"	LOOP / LOOP
12"	B2012-625R	C2012-625R	31.25"	19.25"	LOOP / LOOP
14"	B2014-625R	C2014-625R	35.25"	21.25"	LOOP / LOOP
16"	B2016-625R	C2016-625R	39.25"	23.25"	LOOP / LOOP

2.0 SMOOTH BODY REMOTE RESEVOIR W/ STEM & LOOP 5/8 SHAFT					
TRAVEL	BLACK FINISH	CHROME FINISH	EXTENDED LENGTH	COLLAPSED LENGTH	ENDS
5"	B2050-625RS	C2050-625RS	15.90"	10.90"	STEM / LOOP
6.5"	B2065-625RS	C2065-625RS	19.00"	12.50"	STEM / LOOP
8.5"	B2085-625RS	C2085-625RS	23.00"	14.50"	STEM / LOOP
10"	B2010-625RS	C2010-625RS	26.25"	16.25"	STEM / LOOP
11"	B2011-625RS	C2011-625RS	28.25"	17.25"	STEM / LOOP
12"	B2012-625RS	C2012-625RS	31.25"	19.25"	STEM / LOOP
14"	B2014-625RS	C2014-625RS	35.25"	21.25"	STEM / LOOP
16"	B2016-625RS	C2016-625RS	39.25"	23.25"	STEM / LOOP

2.0 SMOOTH BODY REMOTE RESEVOIR W/ STEM & U 5/8 SHAFT					
TRAVEL	BLACK FINISH	CHROME FINISH	EXTENDED LENGTH	COLLAPSED LENGTH	ENDS
5"	B2050-625RSU	C2050-625RSU	15.90"	10.90"	STEM / U
6.5"	B2065-625RSU	C2065-625RSU	19.00"	12.50"	STEM / U
8.5"	B2085-625RSU	C2085-625RSU	23.00"	14.50"	STEM / U
10"	B2010-625RSU	C2010-625RSU	26.25"	16.25"	STEM / U
11"	B2011-625RSU	C2011-625RSU	28.25"	17.25"	STEM / U
12"	B2012-625RSU	C2012-625RSU	31.25"	19.25"	STEM / U
14"	B2014-625RSU	C2014-625RSU	35.25"	21.25"	STEM / U

2.0 SMOOTH BODY REMOTE RESEVOIR W/ U & U 5/8 SHAFT					
TRAVEL	BLACK FINISH	CHROME FINISH	EXTENDED LENGTH	COLLAPSED LENGTH	ENDS
5"	B2050-625RUU	C2050-625RUU	15.90"	10.90"	U / U
6.5"	B2065-625RUU	C2065-625RUU	19.00"	12.50"	U / U
8.5"	B2085-625RUU	C2085-625RUU	23.00"	14.50"	U / U
10"	B2010-625RUU	C2010-875RUU	26.25"	16.25"	U / U
11"	B2011-625RUU	C2011-875RUU	28.25"	17.25"	U / U
12"	B2012-625RUU	C2012-875RUU	31.25"	19.25"	U / U
14"	B2014-625RUU	C2014-875RUU	35.25"	21.25"	U / U

2.0 SMOOTH BODY REMOTE RESEVOIR W/ U & LOOP 5/8 SHAFT					
TRAVEL	BLACK FINISH	CHROME FINISH	EXTENDED LENGTH	COLLAPSED LENGTH	ENDS
5"	B0550-625RUL	C2050-625RUL	15.90"	10.90"	U / LOOP
6.5"	B2065-625RUL	C2065-625RUL	19.00"	12.50"	U / LOOP
8.5"	B2085-625RUL	C2085-625RUL	23.00"	14.50"	U / LOOP
10"	B2010-625RUL	C2010-625RUL	26.25"	16.25"	U / LOOP
11"	B2011-625RUL	C2011-625RUL	28.25"	17.25"	U / LOOP
12"	B2012-625RUL	C2012-625RUL	31.25"	19.25"	U / LOOP
14"	B2014-625RUL	C2014-625RUL	35.25"	21.25"	U / LOOP

2.0 SMOOTH BODY REMOTE RESEVOIR W/ LOOP & LOOP 5/8 SHAFT					
TRAVEL	BLACK FINISH	CHROME FINISH	EXTENDED LENGTH	COLLAPSED LENGTH	ENDS
5"	B2050-625CO	C2050-625CO	15.90"	10.90"	LOOP / LOOP
6.5"	B2065-625CO	C2065-625CO	19.00"	12.50"	LOOP / LOOP
8.5"	B0585-625CO	C2085-625CO	23.00"	14.50"	LOOP / LOOP
10"	B2010-625CO	C2010-625CO	26.25"	16.25"	LOOP / LOOP
11"	B2011-625CO	C2011-625CO	28.25"	17.25"	LOOP / LOOP
12"	B2012-625CO	C2012-625CO	31.25"	19.25"	LOOP / LOOP
14"	B2014-625CO	C2014-625CO	35.25"	21.25"	LOOP / LOOP
16"	B2016-625CO	C2016-625CO	39.25"	23.25"	LOOP / LOOP

2.0 SMOOTH BODY REMOTE RESEVOIR COILOVER W/ LOOP & LOOP 5/8 SHAFT					
TRAVEL	BLACK FINISH	CHROME FINISH	EXTENDED LENGTH	COLLAPSED LENGTH	ENDS
5"	B2050-625RCO	C2050-625RCO	15.90"	10.90"	LOOP / LOOP
6.5"	B2065-625RCO	C2065-625RCO	19.00"	12.50"	LOOP / LOOP
8.5"	B2085-625RCO	C2085-625RCO	23.00"	14.50"	LOOP / LOOP
10"	B2010-625RCO	C2010-625RCO	26.25"	16.25"	LOOP / LOOP
11"	B2011-625RCO	C2011-625RCO	28.25"	17.25"	LOOP / LOOP
12"	B2012-625RCO	C2012-625RCO	31.25"	19.25"	LOOP / LOOP
14"	B2014-625RCO	C2014-625RCO	35.25"	21.25"	LOOP / LOOP
16"	B2016-625RCO	C2016-625RCO	39.25"	23.25"	LOOP / LOOP



2.5 SHOCKS

2.5
FTS SHOCKS
EMULSION, REMOTE RESEVOIR, COILOVER

The 2.5" Full Throttle Suspension shocks have 51% more piston area and oil capacity than our 2.0" line, providing greater dampening rates for heavier vehicles and more severe applications. These shocks are ideal for off-road buggies, long travel sand cars, and performance street vehicles. Full Throttle Suspension 2.5" shocks have all the high performance attributes as our 2.0" line with added capacity for greater performance.



2.5" SMOOTH BODY EMULSION 7/8 SHAFT					
TRAVEL	BLACK FINISH	CHROME FINISH	EXTENDED LENGTH	COLLAPSED LENGTH	ENDS
6.0"	B2560-875E	C2565-875E	20.80"	14.80"	LOOP / LOOP
8.0"	B2580-875E	C2585-875E	24.80"	16.80"	LOOP / LOOP
10"	B2510-875E	C2510-875E	29.80"	19.80"	LOOP / LOOP
12"	B2512-875E	C2512-875E	33.80"	21.80"	LOOP / LOOP
14"	B2514-875E	C2514-875E	38.80"	24.80"	LOOP / LOOP
16"	B2516-875E	C2516-875E	42.80"	26.80"	LOOP / LOOP
18"	B2518-875E	C2518-875E	46.80"	28.80"	LOOP / LOOP

2.5 SMOOTH BODY REMOTE RESEVOIR 7/8 SHAFT					
TRAVEL	BLACK FINISH	CHROME FINISH	EXTENDED LENGTH	COLLAPSED LENGTH	ENDS
6.0"	B2560-875R	C2565-875R	20.80"	14.80"	LOOP / LOOP
8.0"	B2580-875R	C2585-875R	24.80"	16.80"	LOOP / LOOP
10"	B2510-875R	C2510-875R	29.80"	19.80"	LOOP / LOOP
12"	B2512-875R	C2512-875R	33.80"	21.80"	LOOP / LOOP
14"	B2514-875R	C2514-875R	38.80"	24.80"	LOOP / LOOP
16"	B2516-875R	C2516-875R	42.80"	26.80"	LOOP / LOOP
18"	B2518-875R	C2518-875R	46.80"	28.80"	LOOP / LOOP

2.5 SMOOTH BODY REMOTE RESEVOIR W/ STEM 7/8 SHAFT					
TRAVEL	BLACK FINISH	CHROME FINISH	EXTENDED LENGTH	COLLAPSED LENGTH	ENDS
6.0"	B2560-875RS	C2565-875RS	20.80"	14.80"	STEM / LOOP
8.0"	B2580-875RS	C2585-875RS	24.80"	16.80"	STEM / LOOP
10"	B2510-875RS	C2510-875RS	29.80"	19.80"	STEM / LOOP
12"	B2512-875RS	C2512-875RS	33.80"	21.80"	STEM / LOOP
14"	B2514-875RS	C2514-875RS	38.80"	24.80"	STEM / LOOP
16"	B2516-875RS	C2516-875RS	42.80"	26.80"	STEM / LOOP
18"	B2518-875RS	C2518-875RS	46.80"	28.80"	STEM / LOOP

2.5 SMOOTH BODY EMULSION COILOVER 7/8 SHAFT					
TRAVEL	BLACK FINISH	CHROME FINISH	EXTENDED LENGTH	COLLAPSED LENGTH	ENDS
6.0"	B2560-875ECO	C2565-875ECO	20.80"	14.80"	LOOP / LOOP
8.0"	B2580-875ECO	C2585-875ECO	24.80"	16.80"	LOOP / LOOP
10"	B2510-875ECO	C2510-875ECO	29.80"	19.80"	LOOP / LOOP
12"	B2512-875ECO	C2512-875ECO	33.80"	21.80"	LOOP / LOOP
14"	B2514-875ECO	C2514-875ECO	38.80"	24.80"	LOOP / LOOP
16"	B2516-875ECO	C2516-875ECO	42.80"	26.80"	LOOP / LOOP
18"	B2518-875ECO	C2518-875ECO	46.80"	28.80"	LOOP / LOOP

2.5 SMOOTH BODY REMOTE RESEVOIR COILOVER 7/8 SHAFT					
TRAVEL	BLACK FINISH	CHROME FINISH	EXTENDED LENGTH	COLLAPSED LENGTH	ENDS
6.0"	B2560-875RCO	C2565-875RCO	20.80"	14.80"	LOOP / LOOP
8.0"	B2580-875RCO	C2585-875RCO	24.80"	16.80"	LOOP / LOOP
10"	B2510-875RCO	C2510-875RCO	29.80"	19.80"	LOOP / LOOP
12"	B2512-875RCO	C2512-875RCO	33.80"	21.80"	LOOP / LOOP
14"	B2514-875RCO	C2514-875RCO	38.80"	24.80"	LOOP / LOOP
16"	B2516-875RCO	C2516-875RCO	42.80"	26.80"	LOOP / LOOP
18"	B2518-875RCO	C2518-875RCO	46.80"	28.80"	LOOP / LOOP

2.0 SHOCKS W/ 7/8 SHAFT

2.0 SMOOTH BODY EMULSION 7/8 SHAFT					
TRAVEL	BLACK FINISH	CHROME FINISH	EXTENDED LENGTH	COLLAPSED LENGTH	ENDS
5"	B2050-875E	C2050-875E	15.90"	10.90"	LOOP / LOOP
6.5"	B2065-875E	C2065-875E	19.00"	12.50"	LOOP / LOOP
8.5"	B2085-875E	C2085-875E	23.00"	14.50"	LOOP / LOOP
10"	B2010-875E	C2010-875E	26.25"	16.25"	LOOP / LOOP
11"	B2011-875E	C2011-875E	28.25"	17.25"	LOOP / LOOP
12"	B2012-875E	C2012-875E	31.25"	19.25"	LOOP / LOOP
14"	B2014-875E	C2014-875E	35.25"	21.25"	LOOP / LOOP
16"	B2016-875E	C2016-875E	39.25"	23.25"	LOOP / LOOP

2.0 SMOOTH BODY EMULSION W/ STEM 7/8 SHAFT					
TRAVEL	BLACK FINISH	CHROME FINISH	EXTENDED LENGTH	COLLAPSED LENGTH	ENDS
5"	B2050-875ES	C2050-875ES	15.90"	10.90"	STEM / LOOP
6.5"	B2065-875ES	C2065-875ES	19.00"	12.50"	STEM / LOOP
8.5"	B2085-875ES	C2085-875ES	23.00"	14.50"	STEM / LOOP
10"	B2010-875ES	C2010-875ES	26.25"	16.25"	STEM / LOOP
11"	B2011-875ES	C2011-875ES	28.25"	17.25"	STEM / LOOP
12"	B2012-875ES	C2012-875ES	31.25"	19.25"	STEM / LOOP
14"	B2014-875ES	C2014-875ES	35.25"	21.25"	STEM / LOOP
16"	B2016-875ES	C2016-875ES	39.25"	23.25"	STEM / LOOP

2.0 SMOOTH BODY REMOTE RESEVOIR W/ STEM 7/8 SHAFT					
TRAVEL	BLACK FINISH	CHROME FINISH	EXTENDED LENGTH	COLLAPSED LENGTH	ENDS
5"	B2050-875R	C2050-875R	15.90"	10.90"	STEM / LOOP
6.5"	B2065-875R	C2065-875R	19.00"	12.50"	STEM / LOOP
8.5"	B2085-875R	C2085-875R	23.00"	14.50"	STEM / LOOP
10"	B2010-875R	C2010-875R	26.25"	16.25"	STEM / LOOP
11"	B2011-875R	C2011-875R	28.25"	17.25"	STEM / LOOP
12"	B2012-875R	C2012-875R	31.25"	19.25"	STEM / LOOP
14"	B2014-875R	C2014-875R	35.25"	21.25"	STEM / LOOP
16"	B2016-875R	C2016-875R	39.25"	23.25"	STEM / LOOP

2.0 SMOOTH BODY REMOTE RESEVOIR W/STEM & U 7/8 SHAFT					
TRAVEL	BLACK FINISH	CHROME FINISH	EXTENDED LENGTH	COLLAPSED LENGTH	ENDS
5"	B2050-875RSU	C2050-875RSU	15.90"	10.90"	STEM / U
6.5"	B2065-875RSU	C2065-875RSU	19.00"	12.50"	STEM / U
8.5"	B2085-875RSU	C2085-875RSU	23.00"	14.50"	STEM / U
10"	B2010-875RSU	C2010-875RSU	26.25"	16.25"	STEM / U
11"	B2011-875RSU	C2011-875RSU	28.25"	17.25"	STEM / U
12"	B2012-875RSU	C2012-875RSU	31.25"	19.25"	STEM / U
14"	B2014-875RSU	C2014-875RSU	35.25"	21.25"	STEM / U

2.0 SMOOTH BODY REMOTE RESEVOIR W/U & U 7/8 SHAFT					
TRAVEL	BLACK FINISH	CHROME FINISH	EXTENDED LENGTH	COLLAPSED LENGTH	ENDS
5"	B2050-875RUU	C2050-875RUU	15.90"	10.90"	U / U
6.5"	B2065-875RUU	C2065-875RUU	19.00"	12.50"	U / U
8.5"	B2085-875RUU	C2085-875RUU	23.00"	14.50"	U / U
10"	B2010-875RUU	C2010-875RUU	26.25"	16.25"	U / U
11"	B2011-875RUU	C2011-875RUU	28.25"	17.25"	U / U
12"	B2012-875RUU	C2012-875RUU	31.25"	19.25"	U / U
14"	B2014-875RUU	C2014-875RUU	35.25"	21.25"	U / U

2.0 SMOOTH BODY REMOTE RESEVOIR W/U & LOOP 7/8 SHAFT					
TRAVEL	BLACK FINISH	CHROME FINISH	EXTENDED LENGTH	COLLAPSED LENGTH	ENDS
5"	B2050-875RUL	C2050-875RUL	15.90"	10.90"	U / LOOP
6.5"	B2065-875RUL	C2065-875RUL	19.00"	12.50"	U / LOOP
8.5"	B2085-875RUL	C2085-875RUL	23.00"	14.50"	U / LOOP
10"	B2010-875RUL	C2010-875RUL	26.25"	16.25"	U / LOOP
11"	B2011-875RUL	C2011-875RUL	28.25"	17.25"	U / LOOP
12"	B2012-875RUL	C2012-875RUL	31.25"	19.25"	U / LOOP
14"	B2014-875RUL	C2014-875RUL	35.25"	21.25"	U / LOOP

2.0 SMOOTH BODY REMOTE RESEVOIR 7/8 SHAFT					
TRAVEL	BLACK FINISH	CHROME FINISH	EXTENDED LENGTH	COLLAPSED LENGTH	ENDS
5"	B2050-875R	C2050-875R	15.90"	10.90"	LOOP / LOOP
6.5"	B2065-875R	C2065-875R	19.00"	12.50"	LOOP / LOOP
8.5"	B2085-875R	C2085-875R	23.00"	14.50"	LOOP / LOOP
10"	B2010-875R	C2010-875R	26.25"	16.25"	LOOP / LOOP
11"	B2011-875R	C2011-875R	28.25"	17.25"	LOOP / LOOP
12"	B2012-875R	C2012-875R	31.25"	19.25"	LOOP / LOOP
14"	B2014-875R	C2014-875R	35.25"	21.25"	LOOP / LOOP
16"	B2016-875R	C2016-875R	39.25"	23.25"	LOOP / LOOP

GALLERY / INSTALLS

Double Shock Hoops & Upper Control Arms
 2011 -2013 GM 2500HD/3500HD 4", 7", 10" KITS
 Part # 48139



Radius Arm Kit
 2008 -2013 FORD F250/F350
 Part # 87540



Double Shock Hoops & FTS Shocks
 2010 -2012 DODGE 2500/3500
 Part # 63900



Traction Bar Kit
 2000 -2010 GM 2500HD/3500HD 9.5", 12", 16" KITS
 Part # 14968



Hairs Joint Steering Kit w/ U Brackets
 2011 -2013 GM 2500HD/3500HD 15" KIT
 Part # 49143



Air Bag and Bracket Kit
 2000 -2010 GM 1500HD/2500HD/3500HD 9.5" KIT
 Part # 85250



FTS 25 REMOTE RESERVOIR COILOVER
 2007 -2013 GM 1500 7" KIT
 Part # C8500-7R



Double Rear Hoops
 2007 -2013 GM 1500 7" KIT
 Part # 85055



Dual Steering Stabilizer
 2010 -2013 DODGE 2500/3500
 Part # 48139



Upper Control Arms
 2009 -2013 Ford F150
 Part # 48139



Double Rear Shock Bracket & Shocks
 2007 -2013 GM 1500 7", 10", 15" KITS
 Part # 85049



Double Shock Hoops & Upper Control Arms
 2007 -2013 GM 1500 7" KIT
 Part # 84941



GALLERY / INSTALLS

2011 Chevy Silverado 2500HD 10" Lift

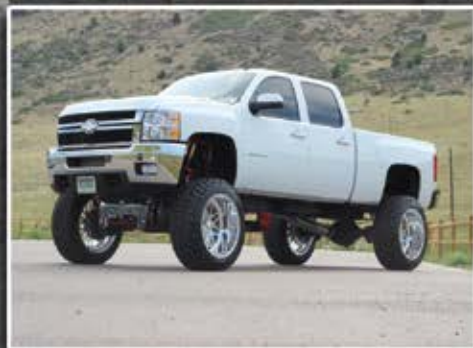

2005 Dodge Ram 3500 10" Lift



2008 Hummer H2 9.5" Lift



2010 GMC Sierra 2500HD 7" Lift



2006 Ford F150 10" Lift



2008 Dodge Ram 2500 8" Lift



2009 Ford F150 6" Lift



2003 Chevy Straight-Axle Comstock 10" Lift



2007 Nissan Titan 6" Lift



2008 GMC Yukon 1000 7" Lift



2011 Ford F150 8" Lift



2010 Chevy Silverado 2500 12" Lift



The following terms and conditions are for the purchasing of products from Full Throttle Suspension. By purchasing a product from Full Throttle Suspension, you agree to follow and to be bound by these terms. Full Throttle Suspension warrants its new products to be free from structural defects in material and workmanship for as long as they are owned by the original purchaser unless otherwise stated.

Full Throttle Suspension's limited warranty specifically does not apply to products which have been (a) modified or altered in anyway; (b) subject to adverse conditions such as misuse, neglect, accident, improper installation or adjustment, dirt or other contaminants, water corrosion, or faulty repair; (c) any product used for racing; (d) used in a manner other than what is specifically recommended in the Full Throttle Suspension catalog; (e) any product that is not manufactured by Full Throttle Suspension.

There are no warranties that extend beyond those stated here. Full Throttle Suspension offers no other warranties, express or implied beyond this Limited Warranty.

In the event of an alleged defect in material or workmanship, Full Throttle Suspension's responsibility is strictly to repair or replace the defective product. Full Throttle Suspension has no other obligation express or implied. Final warranty determination will be at the sole discretion of Full Throttle Suspension.

Full Throttle Suspension shall not be responsible for: (a) actual or alleged labor, transportation, shipping or other incidental charges; (b) actual, consequential or other damages incurred by use of any product of Full Throttle Suspension.

To initiate the warranty process:

Returns and exchanges will be accepted with a "Returns Good Authorization" number from Full Throttle Suspension. R.G.A numbers are to be given only by the shipping and returns dept. at Full Throttle Suspension. R.G.A numbers are only valid for 30 days from the date issued. Write this number on the outside of your return package and tag the goods inside with your name and R.G.A number. A R.G.A. does NOT guarantee replacement or refund, but only that we will inspect the merchandise based upon your claim. Non-defective items must be returned in new, resalable condition, in original packaging and are subject to a 40% restocking fee. The 40% restocking fee is to cover: (a) Time spent handling and shipping of original product; (b) Time inspecting product on its return; (c) re packaging of product to be re-sold.

This Limited Warranty sets forth legal rights. The consumer may have other rights as results in variations in state and providence laws. This Limited Warranty supersedes all prior warranty statements. Inquires concerning this warranty should be directed to:

Full Throttle Suspension
Warranty Return Department
3551 W. Ashlan Avenue
Fresno, CA 93722
(559) 271-8685

Materials and Specifications:

Materials, design and specifications are subject to change without notice. All merchandise information presented in this guide was true and correct at the time of publication. We consistently update our products and merchandise to offer our customers the highest quality parts and accessories available.

Full Throttle is not responsible for any misprint typographical error all prices and product are subject to change without notice

3551 W. ASHALAN AVE. FRESNO, CA 93722

ORDER LINE DIRECT: 559.271.8685

FAX: 559.271.8629

EMAIL:

SALES@FULLTHROTLESUSPENSION.COM



SALES LINE DIRECT: 559.271.8685

FullThrottleSuspension.com